

SURVEY LOCATION
950 EAST 25TH STREET
OGDEN, UTAH

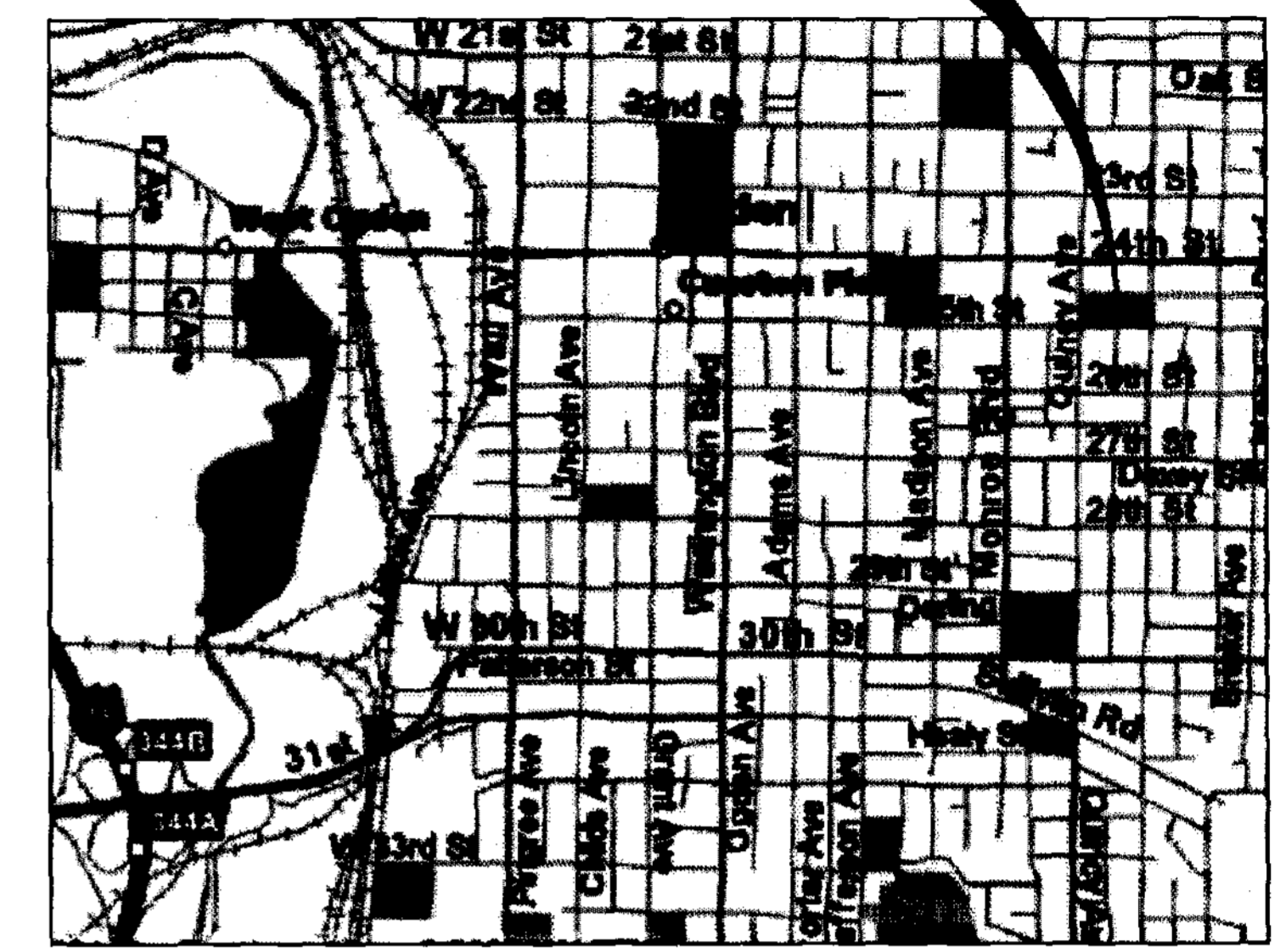

VICINITY MAP
N.T.S.

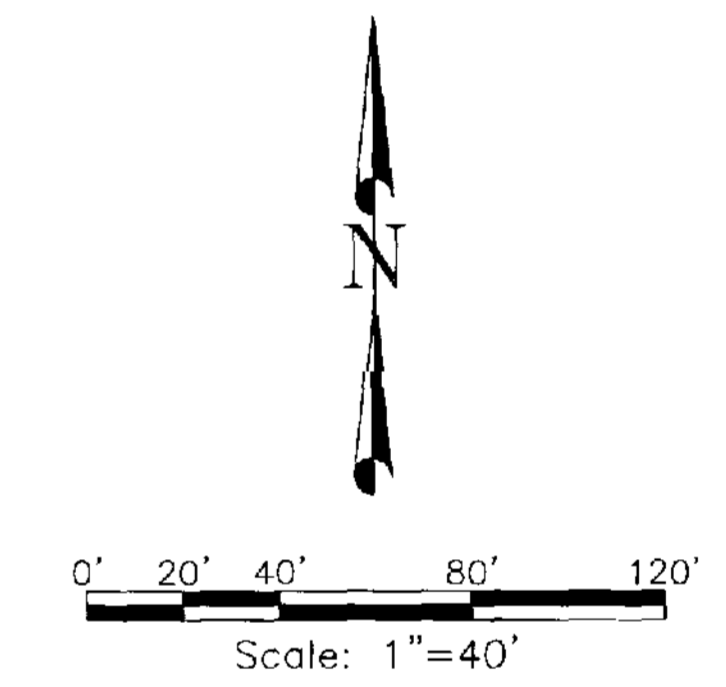

SURVEYOR'S CERTIFICATE

I, James D. Pitkin, a Registered Professional Land Surveyor as prescribed by the laws of the State of Utah and holding License Number 171546 do hereby certify that a survey of the described property was made under my direction and that the map hereon is a true and correct representation of said survey.

Date: September 28, 2004

James D. Pitkin, PLS.
License No. 171546



RECORD DESCRIPTION

(Schedule A, Order No. 287238)
(Parcel Serial No. 02-029-0001)

ALL OF LOTS 1 TO 5, INCLUSIVE, BLOCK 32, PLAT "C", OGDEN CITY SURVEY, ACCORDING TO THE OFFICIAL PLAT THEREOF, ON FILE AND OF RECORD IN THE WEBER COUNTY RECORDER'S OFFICE.

NARRATIVE

A boundary survey of the subject property was requested by the State of Utah, DFCM. The Basis of Bearings for this survey is N89°02'00"W 759.11 feet measured along the monument line of 25TH Street between the monuments found in the intersections of Jackson Avenue and Quincy Avenue and referenced on that certain Record of Survey Map No. 1757 as filed in the Office of the Weber County Surveyor.

RECEIVED
SEP 28 04
Weber County Surveyor
003336

H:\2004\04164 Ogden DCFS\Drawings\ROS.dwg 9/27/2004 3:22:08 PM MDT

NO.	REVISIONS	BY	DATE

DRAWN	9/04GKT	CHECKED	9/04 JDP
DESIGNED	9/27/04	DATE	JDP
APPROVED	9/27/04	DATE	JDP

This document or any part thereof in detail or design concept is the personal property of Forsgren Associates / Inc. and shall not be copied without the written authorization of Forsgren Associates / Inc.

STATE OF UTAH
Division of Facilities
Construction & Management
PROJECT NO. 02026300



RECORD OF SURVEY MAP
DIVISION OF CHILD & FAMILY SERVICES
BLOCK 32, PLAT "C", OGDEN CITY SURVEY
LOCATED IN THE SE 1/4, SECTION 28, T6N, R1W, SLB&M

PROJECT NO:	504-164
SHEET NO:	1 of 1
FILE NAME:	ROS.dwg
SCALE:	1"=40'