

**Rex Behap
As Surveyed Description**

A PART OF THE NORTHWEST QUARTER OF SECTION 31, TOWNSHIP 7 NORTH, RANGE 1 WEST OF THE SALT LAKE BASE AND MERIDIAN.
 BEGINNING AT A POINT ON THE SOUTH RIGHT-OF-WAY LINE OF 2700 NORTH STREET LOCATED NORTH 89°21'18" WEST 1395.70 FEET ALONG THE NORTH LINE OF SAID NORTHWEST QUARTER AND SOUTH 00°38'42" WEST 51.79 FEET FROM THE NORTHEAST CORNER OF SAID NORTHWEST QUARTER; RUNNING THENCE SOUTH 01°33'04" WEST 836.47 FEET TO THE NORTH RIGHT-OF-WAY LINE OF 2550 NORTH STREET; THENCE NORTH 89°28'01" WEST 366.97 FEET ALONG SAID RIGHT-OF-WAY LINE; THENCE NORTH 45°30'47" WEST 127.20 FEET TO THE EAST RIGHT-OF-WAY LINE OF 1000 WEST STREET; THENCE NORTH 01°27'48" EAST 721.90 FEET ALONG SAID RIGHT-OF-WAY LINE; THENCE NORTH 45°48'19" EAST 36.59 FEET TO SAID SOUTH RIGHT-OF-WAY LINE OF 2700 NORTH STREET; THENCE SOUTH 89°30'17" EAST 435.69 FEET ALONG SAID RIGHT-OF-WAY LINE TO THE POINT OF BEGINNING.
 CONTAINING 8.739 ACRES.

Rex Behap
Containing 8.739 Acres

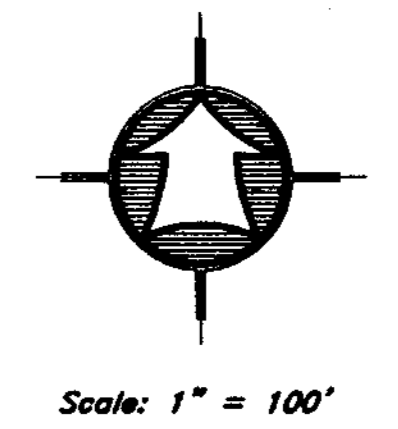

LEGEND:

	PROPERTY LINE
	CENTERLINE
	CURB & GUTTER
	EDGE OF PAVEMENT
	DITCH
	FENCE LINE
	STREET MONUMENT
	SET 5/8" REBAR W/ CAP
	SET 09/14/2008

SURVEY CERTIFICATE

I, K. Greg Hansen, do hereby certify that I am a Registered Land Surveyor, and that I hold Certificate No. 167819 as prescribed by the Laws of the State of Utah, and that I have made and/or Supervised the survey of the property shown and described hereon and that this plat is a true and correct representation of said survey to the best of my knowledge and belief.

K. Greg Hansen, R.L.S. No. 167819
 K. GREG HANSEN
 STATE OF UTAH
 Date: 10/15/08

RECEIVED
 DEC 08 2006
 WEBER CO SURVEYOR

Narrative
 The purpose of this survey was to establish and set the property corners of the parcel as shown and described hereon. The survey was ordered by Rex Behap. The control used to establish the property corners was the existing Weber County Survey Monumentation surrounding Section 31, T7N, R1W, SLB&M. The basis of bearing is the North line of the northwest quarter of said Section assumed to bear North 89°21'18" West per the UDOT 2700 North Right-of-Way drawings. Said Right-of-Way drawings were used to establish north and west property lines. The east property line is that of record coming from the northeast corner of said northwest quarter. Crow rebar were found on the north of the parcel to the east. These Rebar match newly constructed fence lines, but do not match record as shown hereon.

<p>HANSEN & ASSOCIATES, INC. Consulting Engineers and Land Surveyors</p> <p>538 North Main 67 East 100 North Brigham City, Utah 84302 Logan, Utah 84321</p> <p>Brigham City, Utah (435) 752-3491 Ogden, Utah (801) 399-4905 Logan, Utah (435) 752-8197 Utah (435) 752-8272</p>	No.	Date	By
<p>Drawn By: <u> </u> Date: <u>08/11/08</u></p> <p>Designed By: <u> </u></p> <p>Checked By: <u> </u></p> <p>Approved By: <u> </u></p> <p>Scale: 1" = 100'</p> <p>Drawing File: <u>08-3-135.dwg</u></p> <p>JOB NUMBER: <u>08-3-138</u></p>	<p>PROPERTY SURVEY FOR Janet Woodfield/Connie Behap 1000 West 2700 North Pleasant View, Weber County, Utah A PART OF THE NORTHWEST QUARTER OF SECTION 31, TOWNSHIP 7 NORTH, RANGE 1 WEST, S.L.B. & M.</p>		
SHEET	1	OF	1
SHEETS			