

LOT 8
 ALL OF LOT 8 LINCOLN PROPERTIES SUBDIVISION, MORE PARTICULARLY DESCRIBED AS FOLLOWS:
 A PART OF LOT 23, BLOCK 7, OGDEN FIVE ACRE PLAT A LOCATED IN SECTION 20, TOWNSHIP 6 NORTH, RANGE 1 WEST.
 BEGINNING AT THE SOUTHWEST CORNER OF SAID SUBDIVISION SAID POINT BEING ON THE EAST RIGHT-OF-WAY LINE OF LINCOLN AVENUE LOCATED NORTH 90°00'00" EAST 421.03 FEET AND NORTH 00°00'00" EAST 73.89 FEET FROM THE SOUTHWEST CORNER OF SAID LOT 23; RUNNING THENCE NORTH 00°58'00" EAST 60.00 FEET TO THE SOUTH LINE OF LOT 7 LINCOLN PROPERTIES SUBDIVISION; THENCE ALONG SAID SOUTH LINE OF SAID LOT 7 THE FOLLOWING THREE (3) COURSES: (1) SOUTH 89°02'10" EAST 25.00 FEET; (2) NORTH 80°08'00" EAST 45.75 FEET; (3) SOUTH 71°58'36" EAST 27.56 FEET; THENCE SOUTH 00°58'00" WEST 58.03 FEET TO THE SOUTH LINE OF SAID SUBDIVISION; THENCE ALONG SAID SOUTH LINE THE FOLLOWING TWO (2) COURSES: (1) SOUTH 88°58'15" WEST 71.32 FEET; (2) NORTH 89°02'10" WEST 25.00 FEET TO THE POINT OF BEGINNING. CONTAINING 0.138 ACRES.

004288
RECEIVED
 APR 13 2009
 WEBER CO SURVEYOR

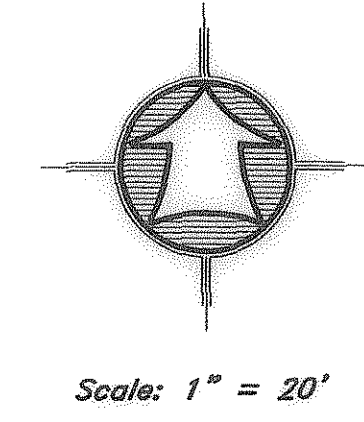

LEGEND:
 ——— PROPERTY LINE
 - - - CENTERLINE
 - - - DEED LINE
 ● FOUND PROPERTY CORNER
 ○ SET 5/8" REBAR W/ CAP

SURVEY CERTIFICATE
 I, K. Greg Hansen, do hereby certify that I am a Registered Land Surveyor, and that I hold Certificate No. 167819 as prescribed by the Laws of the State of Utah, and that I have made and/or Supervised the survey of the property shown and described hereon and that this plat is a true and correct representation of said survey to the best of my knowledge and belief.
 K. Greg Hansen, RLS. No. 167819
 date

Narrative
 The purpose of this survey was to establish and set the property corners of the parcel as shown and described hereon. The survey was ordered by Joe Dunn. The control used to establish the property corners was the existing original survey markers of the Lincoln Properties Subdivision in Section 20, 16N, R1W, SLB&M. The basis of bearing is a line between the curb nail in the projection of the North Property line of Lot 5 and the curb nail in the projection of the South Property line of Lot 8 assumed to bear South 00°48'52" West.

PROPERTY SURVEY FOR		SHEET	
JOE DUNN		1	
1672 So. LINCOLN AVENUE OGDEN, WEBER COUNTY, UTAH		OF	
A PART OF LOT 23, BLOCK 7, OGDEN FIVE ACRE PLAT A, SEC. 20 TOWNSHIP 6 NORTH, RANGE 1 WEST, S.L.B. & M.		1	
		SHEETS	
Drawn By: KHW	Date: 12/28/08	No.	Date
Designed By: —			
Checked By: —			
Approved By: —			
Scale: 1" = 20'			
Drawing File: 08-5-246.DWG			
JOB NUMBER: 08-5-246			
HANSEN & ASSOCIATES, INC. Consulting Engineers and Land Surveyors 536 North Main Brigham City, Utah 84302 (435) 723-3491 (435) 723-7663		Logan Ogden (435) 599-4905 (435) 752-8272	