

CURRENT DESCRIPTION FOR PARCEL 12-057-0022

BEGINNING ON THE EAST RIGHT-OF-WAY LINE OF WASHINGTON BOULEVARD AT A POINT SOUTH 00°58'40" WEST 657.36 FEET AND NORTH 89°00'18" WEST 669.66 FEET AND NORTH 00°50'15" EAST 105.00 FEET FROM THE NORTHEAST CORNER OF SECTION 17, TOWNSHIP 6 NORTH, RANGE 1 WEST, SALT LAKE BASE AND MERIDIAN; SAID BEGINNING POINT BEING ALSO SOUTH 00°50'15" WEST 546.04 FEET AND SOUTH 89°00'18" EAST 66.00 FEET FROM THE OGDEN CITY SURVEY MONUMENT AT THE INTERSECTION OF WASHINGTON BOULEVARD AND SOUTHWELL STREETS; RUNNING THENCE NORTH 00°50'15" EAST ALONG THE EAST RIGHT-OF-WAY LINE OF WASHINGTON BOULEVARD 80 FEET; THENCE SOUTH 89°00'18" EAST 225.00 FEET; THENCE SOUTH 00°50'15" WEST 80 FEET; THENCE NORTH 89°00'18" WEST 225.00 FEET TO THE POINT OF BEGINNING.

SUBJECT TO A 20 FOOT WIDE RIGHT OF WAY AS DISCLOSED ON THAT CERTAIN AMENDMENT TO RIGHT OF WAY AGREEMENT RECORDED JUNE 14, 1984 AS ENTRY NO. 911202, IN BOOK 1448 PAGE 193, THE CENTER LINE OF SAID 20 FOOT WIDE RIGHT OF WAY IS DESCRIBED AS FOLLOWS: THE WESTERLY 200 FEET OF THE SOUTHERN MOST 20 FEET OF THE GRANTORS PROPERTY DESCRIBED AS FOLLOWS: BEGINNING ON THE EAST RIGHT OF WAY LINE OF WASHINGTON BOULEVARD AT A POINT SOUTH 00°58'40" WEST 657.36 FEET AND NORTH 89°00'18" WEST 669.66 FEET AND NORTH 00°50'15" EAST 105.00 FEET FROM THE NORTHEAST CORNER OF SECTION 17, TOWNSHIP 6 NORTH, RANGE 1 WEST, SALT LAKE BASE & MERIDIAN; SAID BEGINNING POINT BEING ALSO SOUTH 00°50'15" WEST 546.04 FEET AND SOUTH 89°00'18" WEST 66.00 FEET FROM THE OGDEN CITY SURVEY MONUMENT AT THE INTERSECTION OF WASHINGTON BLVD AND SOUTHWELL STREET AND RUNNING THENCE NORTH 00°50'15" EAST ALONG THE EAST RIGHT OF WAY LINE OF WASHINGTON BLVD 240.36 FEET, THENCE SOUTH 89°00'18" EAST 225.00 FEET, THENCE SOUTH 00°50'15" WEST 240.36 FEET, THENCE NORTH 89°00'18" WEST 225.00 FEET TO THE POINT OF BEGINNING.

PROPOSED DESCRIPTION FOR 12-057-0022

A PART OF THE NORTHEAST QUARTER OF SECTION 17, TOWNSHIP 6 NORTH, RANGE 1 WEST OF THE SALT LAKE BASE AND MERIDIAN.

BEGINNING ON THE EAST RIGHT OF WAY LINE OF WASHINGTON BOULEVARD AT A POINT SOUTH 00°58'40" WEST 657.36 FEET AND NORTH 89°00'18" WEST 669.66 FEET AND NORTH 00°50'15" EAST 105.00 FEET FROM THE NORTHEAST CORNER OF SAID SECTION 17, SAID POINT ALSO BEING LOCATED SOUTH 00°50'15" WEST 546.04 FEET AND SOUTH 89°00'18" EAST 66.00 FEET FROM THE OGDEN CITY SURVEY MONUMENT AT THE INTERSECTION OF WASHINGTON BOULEVARD AND SOUTHWELL STREET; RUNNING THENCE NORTH 00°50'15" EAST 118.76 FEET ALONG THE SAID EAST RIGHT OF WAY LINE OF WASHINGTON BOULEVARD TO THE PROJECTION OF THE CENTERLINE OF A DIVIDING WALL OF AN EXISTING BUILDING; THENCE SOUTH 89°27'23" EAST 225.00 FEET ALONG THE SAID EXISTING DIVIDING WALL CENTERLINE AND IT'S PROJECTIONS; THENCE SOUTH 00°50'15" WEST 120.54 FEET; THENCE NORTH 89°00'18" WEST 225.00 FEET TO THE POINT OF BEGINNING. CONTAINING 0.618 ACRES.

SUBJECT TO A 20 FOOT WIDE RIGHT OF WAY AS DISCLOSED ON THAT CERTAIN AMENDMENT TO RIGHT OF WAY AGREEMENT RECORDED JUNE 14, 1984 AS ENTRY NO. 911202, IN BOOK 1448 PAGE 193, THE CENTER LINE OF SAID 20 FOOT WIDE RIGHT OF WAY IS DESCRIBED AS FOLLOWS: THE WESTERLY 200 FEET OF THE SOUTHERN MOST 20 FEET OF THE GRANTORS PROPERTY DESCRIBED AS FOLLOWS: BEGINNING ON THE EAST RIGHT OF WAY LINE OF WASHINGTON BOULEVARD AT A POINT SOUTH 00°58'40" WEST 657.36 FEET AND NORTH 89°00'18" WEST 669.66 FEET AND NORTH 00°50'15" EAST 105.00 FEET FROM THE NORTHEAST CORNER OF SECTION 17, TOWNSHIP 6 NORTH, RANGE 1 WEST, SALT LAKE BASE & MERIDIAN; SAID BEGINNING POINT BEING ALSO SOUTH 00°50'15" WEST 546.04 FEET AND SOUTH 89°00'18" WEST 66.00 FEET FROM THE OGDEN CITY SURVEY MONUMENT AT THE INTERSECTION OF WASHINGTON BLVD AND SOUTHWELL STREET AND RUNNING THENCE NORTH 00°50'15" EAST ALONG THE EAST RIGHT OF WAY LINE OF WASHINGTON BLVD 240.36 FEET, THENCE SOUTH 89°00'18" EAST 225.00 FEET, THENCE SOUTH 00°50'15" WEST 240.36 FEET, THENCE NORTH 89°00'18" WEST 225.00 FEET TO THE POINT OF BEGINNING.

CURRENT DESCRIPTION FOR PARCEL 12-057-0026

BEGINNING ON THE EAST RIGHT OF WAY LINE OF WASHINGTON BLVD AT A POINT SOUTH 00°58'40" WEST 472.36 FEET AND NORTH 89°00'18" WEST 669.66 FEET FROM THE NORTHEAST CORNER OF SECTION 17, TOWNSHIP 6 NORTH, RANGE 1 WEST, SALT LAKE BASE AND MERIDIAN, U.S. SURVEY; SAID BEGINNING POINT BEING ALSO SOUTH 00°50'15" WEST 466.04 FEET AND SOUTH 89°00'18" WEST 66.00 FEET FROM THE OGDEN CITY SURVEY MONUMENT AT THE INTERSECTION OF WASHINGTON BOULEVARD AND SOUTHWELL STREET AND RUNNING THENCE NORTH 00°50'15" EAST ALONG THE EAST RIGHT OF WAY LINE OF WASHINGTON BOULEVARD 155.36 FEET, THENCE SOUTH 89°00'18" EAST 225.00 FEET, THENCE SOUTH 00°50'15" WEST 155.36 FEET, THENCE NORTH 89°00'18" WEST 225.00 FEET TO THE POINT OF BEGINNING.

PROPOSED DESCRIPTION FOR PARCEL 12-057-0026

A PART OF THE NORTHEAST QUARTER OF SECTION 17, TOWNSHIP 6 NORTH, RANGE 1 WEST OF THE SALT LAKE BASE AND MERIDIAN.

BEGINNING ON THE EAST RIGHT OF WAY LINE OF WASHINGTON BLVD AT A POINT SOUTH 00°58'40" WEST 433.60 FEET AND NORTH 89°00'18" WEST 669.75 FEET FROM THE NORTHEAST CORNER OF SAID SECTION 17, SAID POINT ALSO BEING LOCATED SOUTH 00°50'15" WEST 427.28 FEET AND SOUTH 89°00'18" EAST 66.00 FEET FROM THE OGDEN CITY SURVEY MONUMENT AT THE INTERSECTION OF WASHINGTON BOULEVARD AND SOUTHWELL STREET; RUNNING THENCE NORTH 00°50'15" EAST 116.60 FEET ALONG THE SAID EAST RIGHT OF WAY LINE OF WASHINGTON BOULEVARD; THENCE SOUTH 89°00'18" EAST 225.00 FEET; THENCE SOUTH 00°50'15" WEST 114.82 FEET TO THE PROJECTION OF THE CENTERLINE OF A DIVIDING WALL OF AN EXISTING BUILDING; THENCE 89°27'23" WEST 225.00 FEET ALONG THE SAID EXISTING DIVIDING WALL CENTERLINE AND IT'S PROJECTIONS TO THE POINT OF BEGINNING. CONTAINING 0.598 ACRES.

WASHINGTON PARK ASSOCIATES, LC 120570003

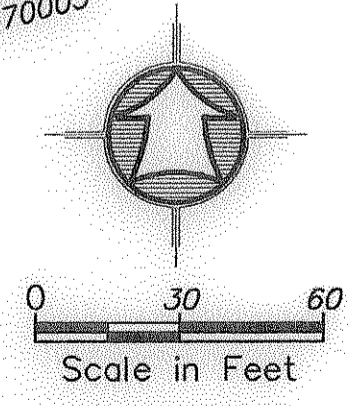

NARRATIVE

The purpose of this survey was to adjust the property line between the parcels as shown and described hereon. The survey was ordered by Nate Brockbank. The control used to establish the property corners was the existing Ogdan City Survey Monumentation adjacent to the subject property. The basis of bearing is the centerline of Washington Boulevard from North Street to Southwell Street (AVC Lane) which bears South 00°50'15" West as currently monumented.

LEGEND:

- PROPERTY LINE
- - - SECONDARY PROPERTY LINE
- · — CENTERLINE
- BUILDING LINE
- - - EASEMENT LINE
- x — FENCE LINE
- x — STREET MONUMENT

SURVEY CERTIFICATE

I, K. Greg Hansen, do hereby certify that I am a Registered Land Surveyor, and that I hold Certificate No. 167819 as prescribed by the Laws of the State of Utah, and that I have made and/or Supervised the survey of the property shown and described hereon and that this plat is a true and correct representation of said survey to the best of my knowledge and belief.

K. Greg Hansen, R.L.S. No. 167819

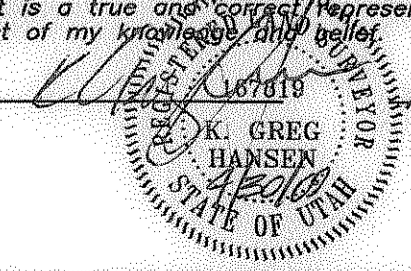

DATE: APR 30 2009

HANSEN & ASSOCIATES, INC.
Consulting Engineers and Land Surveyors
538 North Main, Brigham City, Utah 84302
67 East 100 North, Logan, Utah 84321
Brigham City, Ogden (435) 723-3491 (435) 752-9197
Logan (435) 723-7663 (801) 399-4905 (435) 752-8272

Drawn By: CGH Date: 04/29/09
Designed By: _____
Checked By: _____
Approved By: _____
Scale: 1" = 30'
Drawing File: 09-3-50.DWG
JOB NUMBER: 09-3-50

LOT LINE ADJUSTMENT SURVEY FOR:
No. Ogdan Properties, LLC
150 NORTH WASHINGTON
OGDEN CITY, WEBER COUNTY, UTAH
A PART OF THE NORTHEAST QUARTER OF SECTION 17, TOWNSHIP 6 NORTH, RANGE 1 WEST, SLB&M

No.	Date	By	Revision