

004326
RECEIVED
 JUL 14 2009
 WEBER CO SURVEYOR

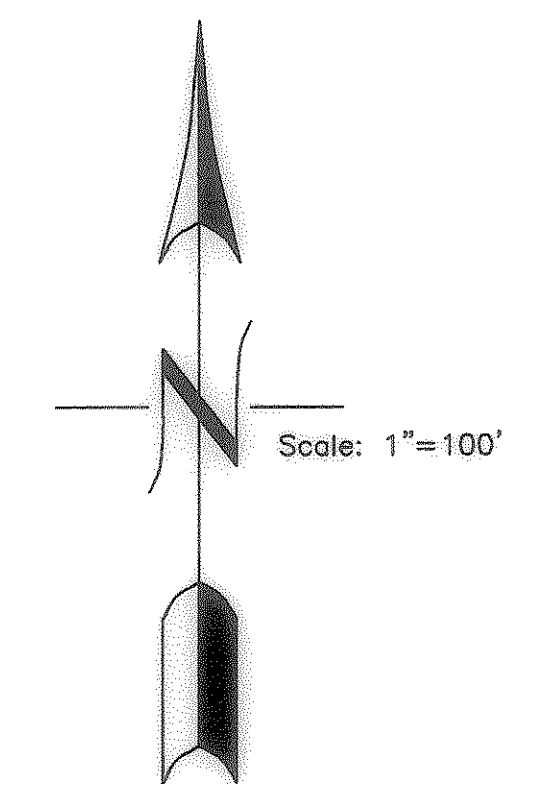

SURVEYED PROPERTY DESCRIPTION

BEING A PART OF THE EAST ONE HALF OF SECTION 10, TOWNSHIP 5 NORTH, RANGE 1 WEST, SALT LAKE BASE AND MERIDIAN, OGDEN CITY, WEBER COUNTY, UTAH;

BEGINNING AT A POINT ON THE SOUTH LINE OF THE NORTHEAST QUARTER OF THE SOUTHEAST QUARTER OF SAID SECTION 10, SAID POINT BEING S0°42'24"W. 1305.66 FEET AND N89°10'14"W 188.40 FEET FROM THE NORTHEAST CORNER OF THE SOUTHEAST QUARTER OF SAID SECTION 10, AND RUNNING: THENCE N89°10'14"W, ALONG THE SOUTH LINE OF THE NORTHEAST QUARTER OF THE SOUTHEAST QUARTER OF SAID SECTION 10, 974.10 FEET; THENCE N0°42'24"E. 330.01 FEET; THENCE N89°10'14"W. 557.50 FEET; THENCE N0°37'00"E. 690.00 FEET; THENCE S89°59'25"E. 250.88 FEET; THENCE N0°37'00"E. 282.29 FEET TO THE NORTH LINE OF THE SOUTHEAST QUARTER OF SAID SECTION 10; THENCE N89°09'26"W., ALONG SAID NORTH LINE, 158.11 FEET; THENCE N0°36'26"E. 323.73 FEET, TO THE SOUTH LINE OF DAK VIEW ESTATES PHASE 3; THENCE ALONG THE SOUTH LINE OF SAID SUBDIVISION THE FOLLOWING TWO COURSES; 1) S89°32'00"E. 181.28 FEET, 2) N59°06'00"E. 160.89 FEET, TO THE WEST LINE OF SKYLINE DRIVE; THENCE, ALONG SAID WEST LINE THE FOLLOWING TWO COURSES; 1) ALONG A CURVE TO THE RIGHT HAVING A RADIUS OF 960.00 FEET A LENGTH OF 137.90 FEET (LONG CHORD BEARS S25°32'29"E. 137.78 FEET), 2) S21°25'34"E. 699.69 FEET; THENCE N89°03'23"W. 328.17 FEET; THENCE S0°59'26"W. 277.08 FEET; THENCE S89°09'24"E. 789.39 FEET; THENCE N0°59'21"E. 126.90 FEET, TO THE WESTERLY LINE OF QUAIL RIDGE ESTATES PHASE # 8 THE FOLLOWING NINE (9) COURSES; 1) S89°01'00"E. 70.52 FEET, 2) S24°01'40"E. 207.40 FEET, 3) S1°28'03"E. 216.38 FEET, 4) S23°56'17"W. 42.51 FEET, 5) S15°21'24"E. 127.11 FEET, 6) S74°39'23"E. 89.57 FEET, 7) S36°20'53"E. 63.57 FEET, 8) S19°44'01"E. 75.95 FEET, 9) S0°47'21"E. 84.78 FEET, TO THE POINT OF BEGINNING.

CONTAINS 27.42 ACRES, MORE OR LESS.

SUBJECT TO RIGHT OF WAY, BOOK 1458-1650

NARRATIVE AND STATEMENT OF PURPOSE

THE PROPERTY SURVEY, DEPICTED BY THIS DRAWING, WAS PERFORMED FOR THE PURPOSE OF COMBINING PARCELS UNDER ONE OWNERSHIP AND STAKING THE OVERALL BOUNDARY, BY REQUEST OF CHAD CARSON, THE OWNER OF THE PROPERTY.

THE SOUTH LINE OF THE NORTHEAST QUARTER OF THE SOUTHEAST QUARTER OF SECTION 10 (1/16 LINE) WAS FOUND NOT TO BE ON THE LINE DETERMINED BY A SECTION BREAKDOWN BUT RATHER WAS REFERENCED BY A NAIL HOLE (THE NAIL IS MISSING) IN A LARGE BOULDER. THIS WAS VERIFIED BY THE COUNTY SURVEYOR. THE BOULDER IS NOW MISSING BUT IT WAS REPLACED BY A CAPPED REBAR.

DEED LINES, PLOTTED FROM THE DESCRIPTIONS, ARE SHOWN ON THE DRAWING TO ILLUSTRATE THE GAPS AND OVERLAPS THAT EXIST "ON PAPER". ONE OF THE PROBLEM AREAS, WITH THESE DEED DESCRIPTIONS, IS ADJACENT TO THE OGDEN CITY PROPERTY AND DAK VIEW ESTATES PHASE 3 AT THE NORTH END OF THE SUBJECT PROPERTY. PART OF THE PROBLEM HERE HAS BEEN RESOLVED WITH AN AGREEMENT WITH THE CITY. ANOTHER AREA OF CONCERN IS THAT PROPERTY DIRECTLY EAST OF FOREST GREEN ESTATES SUBDIVISION AND THE SUBDIVISION ITSELF. IT WAS FOUND THAT THIS SUBDIVISION IS APPROXIMATELY 25 FEET EASTERLY OF ITS PLATTED LOCATION. THIS, IN EFFECT, COMPRESSES THESE PROPERTIES EAST OF THE SUBDIVISION. THERE IS REASON TO BELIEVE THAT WHEN THESE PROPERTIES WERE CREATED THAT THIS PROBLEM WAS KNOWN. ALL OF THE DESCRIPTIONS OF THESE PROPERTIES THAT ADJOIN THE CARSON PROPERTY HAVE MORE OR LESS CALLS IN THE EAST/WEST DIMENSIONS.

BASIS OF BEARING IS AS DEFINED AND STATED ON THE DRAWING.

LEGEND:

- DENOTES A SET #5 CAPPED REBAR 24" LONG
- ▲ DENOTES A SET CURB NAIL
- DENOTES A FOUND CAPPED REBAR
- ◆ DENOTES A MONUMENT
- SECTIONLINE/CENTERLINE
- - - DEED DESCRIBED LINE
- - - SURVEYED PROPERTY LINE
- x EXISTING FENCE

CAP DETAIL

WEST SURVEY
 ROY, UT

SURVEYOR'S CERTIFICATE

I, DICK N. MECHEM, DO HEREBY CERTIFY THAT I AM A PROFESSIONAL LAND SURVEYOR OF THE STATE OF UTAH, HOLDING LICENSE NUMBER 155649 AND THAT THIS MAP IS A TRUE AND COMPLETE REPRESENTATION OF A SURVEY MADE BY ME, OR UNDER MY SUPERVISION, AT THE REQUEST OF GARY CHAD CARSON AND ON BEHALF OF MTNWEST SURVEYING & MAPPING, INC. ALL MONUMENTS SHOWN HEREON ARE OF THE CHARACTER AND OCCUPY THE POSITIONS INDICATED, AND ARE SUFFICIENT TO ENABLE THE SURVEY TO BE RE-TRACED.

DICK N. MECHEM, P.L.S.

DATE: *Jebos*

Professional Seal: DICK N. MECHEM, LICENSE # 155649, STATE OF UTAH

RECORD OF SURVEY
 for
GARY CHAD CARSON

Located in The East One-Half Of Section 10,
 Township 5 North, Range 1 West, S.L.B.&M.

Date: Feb. 2009 No. 48-01-04 Drwn: DNM Ck'd: DRH

MtnWest 1825 W. 4400 S. PO Box 207
 Surveying & Roy, Utah 84067
 Mapping, Inc. Phone: (801) 731-5330 Fax: (801) 731-5331