

004347
RECEIVED
 AUG 25 2009
 WEBER CO SURVEYOR

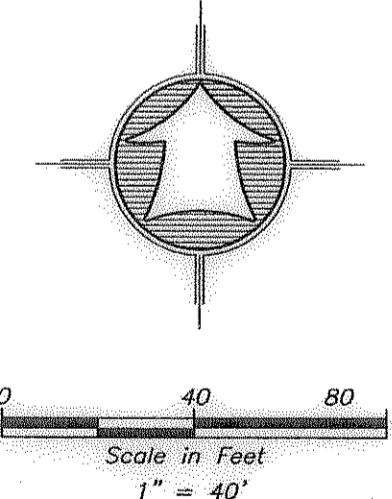

- LEGEND**
- PROPERTY LINE
 - CENTERLINE
 - - - SECTION LINE
 - - - FENCE LINE
 - SECTION CORNER
 - FOUND PROPERTY CORNER SET 5/8" REBAR W/ CAP

SURVEY CERTIFICATE

I, K. Greg Hansen, do hereby certify that I am a Registered Land Surveyor, and that I hold Certificate No. 167819 as prescribed by the Laws of the State of Utah, and that I have made and/or Supervised the survey of the property shown and described hereon and that this plat is a true and correct representation of said survey to the best of my knowledge and belief.

K. Greg Hansen, R.L.S. No. 167819
 date July 16, 2009

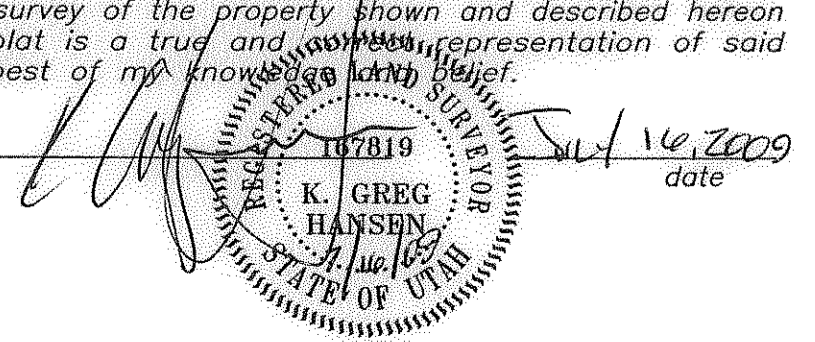

Narrative

The purpose of this survey was to establish and set the property corners of the parcels as shown and described hereon. The survey was ordered by Blaine Willardson. The control used to establish the property corners was the existing Weber County Survey Monumentation surrounding Section 2, T5N, R2W, S2&M. The East line of Parcel A was established by using the existing U.D.O.T. Right-of-Way Lath. The basis of bearing is the West line of the Southwest Quarter of said Section assumed to bear South 00°51'36" West.

PROPERTY SURVEY FOR
BLAIN WILLARDSEN
 MIDLAND DRIVE
 WEST HAVEN, WEBER COUNTY, UTAH
 A PART OF THE SOUTHWEST QUARTER OF SECTION 2

Drawn By: KHW Date: 7/14/09
 Designed By: _____
 Checked By: _____
 Approved By: _____
 Scale: 1" = 40'
 Drawing File: 09-09-3-102PS.DWG

HANSEN & ASSOCIATES, INC.
 Consulting Engineers and Land Surveyors
 558 North Main Brigham City, Utah 84302
 (435) 723-3491 Ogden Logan

SHEET **1** OF **1** SHEETS