

**Narrative**  
 The purpose of this survey was to establish and set the Right-of-Way lines of the Streets as shown and described hereon. The survey was ordered by Jones and Associates in the capacity of Pleasant View City Engineer. The Right-of-Way lines were established by using the Majestic Heights Subdivision No. 2 Amended plat and the Majestic Heights Subdivision No. 7 Plat. The control used to establish the property corners was the existing Weber County Survey Monumentation surrounding Sections 17, 18, 19, and 20, 17N, 17W, SLD&M. The basis of bearing is the South line of the Southwest Quarter of said Section 17 which by record bears North 89°50'47" East.

004388  
**RECEIVED**  
 JAN 13 2010  
 WEBER CO SURVEYOR

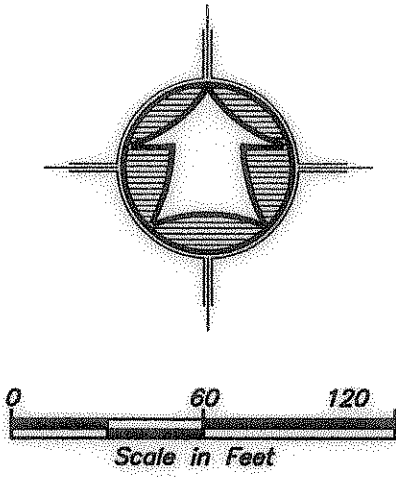

- LEGEND**
- SUBJECT PROPERTY LINE
  - - - ADJONER PROPERTY LINE
  - CENTERLINE
  - - - DITCH
  - - - FENCE LINE
  - - - ENCROACHING GARDEN
  - SECTION CORNER MONUMENT
  - SET 5/8" REBAR W/ CAP

**SURVEY CERTIFICATE**  
 I, K. Greg Hansen, do hereby certify that I am a Registered Land Surveyor, and that I hold Certificate No. 167819 as prescribed by the Laws of the State of Utah, and that I have made and/or Supervised the survey of the property shown and described hereon and that this plat is a true and correct representation of said survey to the best of my knowledge and belief.  
 K. Greg Hansen, R.L.S. No. 167819  
 Nov. 6, 2009 date

**BOUNDARY SURVEY FOR PLEASANT VIEW CITY**  
 4300 NORTH STREET FROM 500 WEST TO 350 WEST PLEASANT VIEW, WEBER COUNTY, UTAH  
 A PART OF THE NE 1/4 OF SEC. 19, & NW 1/4 OF SEC. 20 AND A PART OF THE SE 1/4 OF SEC. 18, & SW 1/4 SEC. 17 TOWNSHIP 7 NORTH, RANGE 1 WEST, S.L.B. & M.

Drawn By: KHV	Date: 10/26/2009
Designed By:	
Checked By:	
Approved By:	
Scale: 1" = 60'	
Drawing File: 09-3-172PS.DWG	
JOB NUMBER: 09-3-172	

**HANSEN & ASSOCIATES, INC.**  
 Consulting Engineers and Land Surveyors  
 538 North Main  
 Brigham City, Utah 84302  
 (435) 723-2481  
 (435) 723-7663  
 (801) 399-4905  
 Ogden Logan  
 (435) 752-8272

No.	Date	By	Revision

SHEET **1** OF **1** SHEETS