

004482  
**RECEIVED**  
 NOV 18 2010  
 WEBER CO SURVEYOR  
 004482

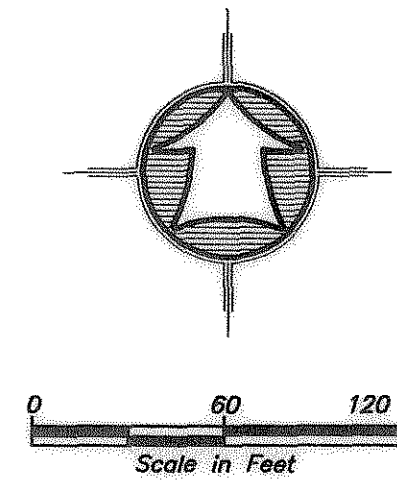

- LEGEND**
- SUBJECT RIGHT-OF-WAY LINE
  - - - ADJOINER PROPERTY LINE
  - - - FUTURE RIGHT-OF-WAY LINE
  - - - CENTERLINE
  - - - P.U.E.
  - - - FENCE LINE
  - ✦ SECTION CORNER
  - ⊕ STREET MONUMENT
  - FOUND PROPERTY CORNER
  - SET 5/8" REBAR W/ CAP

**SURVEY CERTIFICATE**

I, K. Greg Hansen, do hereby certify that I am a Registered Land Surveyor, and that I hold Certificate No. 167819 as prescribed by the Laws of the State of Utah, and that I have made and/or Supervised the survey of the property shown and described hereon and that this plat is a true and correct representation of said survey to the best of my knowledge and belief.

K. Greg Hansen, R.L.S. No. 167819  
 K. GREG HANSEN  
 REGISTERED LAND SURVEYOR  
 STATE OF UTAH  
 date JUNE 23, 2010

**Narrative**

The purpose of this survey was to establish and set the Right-of-Way lines of 4300 North Street and 900 West Street that adjoin Tax Parcel 160120054 as shown and described hereon. The survey was ordered by Jones and Associates as the City Engineer for Pleasant View City. The deeds of the parcels on the South Side of 4300 North call to the section line as the North Boundary and to the Centerline of 900 West as East-West Boundaries. Existing Subdivisions along 4300 North to the East and West of 900 West have dedicated to Pleasant View City a 80.00 foot roadway being 40.00 Feet North and 40.00 Feet South of the Section line. The Centerline of 900 West was established by the K R Ranch Subdivision and a existing description of said street recorded in Book 481, Page 580 of the Weber County Records. The Cool Creek Subdivision Plat dedicated a 30.00 foot half width roadway which does not match other records that show a 25.00 foot half width. The control used to establish the property corners was the existing Weber County Survey Monumentation surrounding Section 18, 17N, R1W, S.L.B.&M. The basis of bearing is the South line of said Section which bears South 89°43'56" East Weber County Grid Bearing.

PROPERTY SURVEY FOR  
**PLEASANT VIEW CITY**  
 900 WEST 4300 NORTH,  
 PLEASANT VIEW, WEBER COUNTY, UTAH  
 A PART OF THE SOUTHEAST QUARTER OF SECTION 18,  
 TOWNSHIP 7 NORTH, RANGE 1 WEST, S.L.B.& M.

SHEET  
**1**  
 OF  
**1**  
 SHEETS

Drawn By: KHW Date: 6/17/10  
 Designed By: -  
 Checked By: -  
 Approved By: -  
 Scale: 1"=60'  
 Drawing File: 10-3-10015.DWG  
 JOB NUMBER: 10-3-100

**HANSEN & ASSOCIATES, INC.**  
 Consulting Engineers and Land Surveyors  
 538 North Main Street, Brigham, Utah 84302  
 Visit us at www.hais.net  
 Ogden City  
 (801) 388-3681 (801) 388-4605 (435) 782-8272

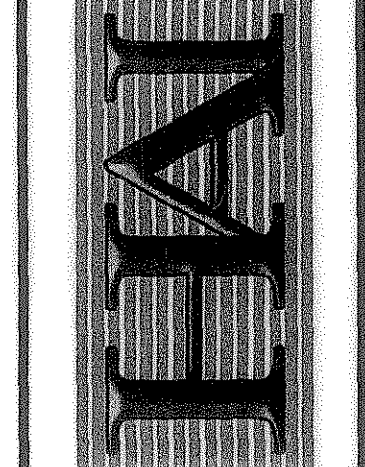

No.	Date	By	Revision