

PARCEL 1
 A PART OF THE SOUTHWEST QUARTER OF THE NORTHWEST QUARTER OF SECTION 14, TOWNSHIP 6 NORTH, RANGE 2 WEST, OF THE SALT LAKE BASE AND MERIDIAN. BEGINNING AT A POINT ON THE SOUTH RIGHT-OF-WAY LINE OF 200 SOUTH STREET BEING THE NORTHWEST CORNER OF SAID SOUTHWEST QUARTER LOCATED NORTH 00°55'40" WEST 1331.05 FEET (NORTH 1329.9 MORE OR LESS BY RECORD) FROM THE WEST QUARTER CORNER OF SAID SECTION 14; RUNNING THENCE ALONG SAID SOUTH RIGHT-OF-WAY LINE AND THE NORTH LINE OF SAID SOUTHWEST QUARTER SOUTH 89°15'11" EAST (EAST BY RECORD) 110.0 FEET; THENCE SOUTH 00°34'24" WEST (SOUTH BY RECORD) 100.0 FEET; THENCE SOUTH 89°25'36" EAST (EAST BY RECORD) 88.54 FEET; THENCE SOUTH 00°34'24" WEST (SOUTH BY RECORD) 20.68 FEET; THENCE NORTH 89°08'30" WEST 195.38 FEET TO THE WEST LINE OF SAID NORTHWEST QUARTER; THENCE ALONG SAID WEST LINE NORTH 00°55'40" WEST 120.75 FEET TO THE POINT OF BEGINNING. CONTAINING 14,909 SQUARE FEET.

PARCEL 2
 A PART OF THE SOUTHWEST QUARTER OF THE NORTHWEST QUARTER OF SECTION 14, TOWNSHIP 6 NORTH, RANGE 2 WEST, OF THE SALT LAKE BASE AND MERIDIAN. BEGINNING AT A POINT LOCATED NORTH 00°55'40" WEST 1210.31 FEET ALONG THE WEST LINE OF SAID SOUTHWEST QUARTER AND SOUTH 89°08'30" EAST 195.38 FEET FROM THE WEST QUARTER CORNER OF SAID SECTION 14; RUNNING THENCE SOUTH 89°08'30" EAST 135.30 FEET; THENCE SOUTH 00°55'40" WEST (SOUTH BY RECORD) 142.69 FEET; THENCE NORTH 89°25'36" WEST (WEST BY RECORD) 139.04 FEET; THENCE NORTH 00°34'24" EAST (NORTH BY RECORD) 143.32 FEET TO THE POINT OF BEGINNING. CONTAINING 19,616 SQUARE FEET.

PARCEL 3
 A PART OF THE SOUTHWEST QUARTER OF THE NORTHWEST QUARTER OF SECTION 14, TOWNSHIP 6 NORTH, RANGE 2 WEST, OF THE SALT LAKE BASE AND MERIDIAN. BEGINNING AT A POINT ON THE WEST LINE OF SAID NORTHWEST QUARTER BEING LOCATED NORTH 00°55'40" WEST 1057.85 FEET ALONG SAID WEST LINE FROM THE WEST QUARTER CORNER OF SAID SECTION 14; RUNNING THENCE NORTH 00°55'40" WEST 8.12 FEET; THENCE SOUTH 89°25'36" EAST 191.59 FEET (EAST 198.54 FEET BY RECORD); THENCE SOUTH 00°34'24" WEST (SOUTH BY RECORD) 5.51 FEET; THENCE SOUTH 89°47'31" WEST 191.40 FEET TO THE POINT OF BEGINNING. CONTAINING 1,305 SQUARE FEET.

PARCEL 4
 A PART OF THE SOUTHWEST QUARTER OF THE NORTHWEST QUARTER OF SECTION 14, TOWNSHIP 6 NORTH, RANGE 2 WEST, OF THE SALT LAKE BASE AND MERIDIAN. BEGINNING AT A POINT ON THE SOUTH RIGHT-OF-WAY LINE OF 200 SOUTH STREET BEING LOCATED NORTH 00°55'40" WEST 1057.85 FEET ALONG SAID WEST LINE AND NORTH 00°55'40" WEST 8.12 FEET AND SOUTH 89°25'36" EAST 191.59 FEET (EAST 198.54 FEET BY RECORD) FROM THE WEST QUARTER CORNER OF SAID SECTION 14; RUNNING THENCE SOUTH 89°25'36" EAST 139.04 FEET (EAST 131.46 FEET BY RECORD); THENCE SOUTH 00°55'40" EAST (SOUTH BY RECORD) 3.61 FEET; THENCE SOUTH 89°47'31" WEST 139.15 FEET; THENCE NORTH 00°34'24" EAST (NORTH BY RECORD) 5.51 FEET TO THE POINT OF BEGINNING. CONTAINING 643 SQUARE FEET.

PARCEL A
 A PART OF THE SOUTHWEST QUARTER OF THE NORTHWEST QUARTER OF SECTION 14, TOWNSHIP 6 NORTH, RANGE 2 WEST, OF THE SALT LAKE BASE AND MERIDIAN. BEGINNING AT A POINT ON THE SOUTH RIGHT-OF-WAY LINE OF 200 SOUTH STREET BEING THE NORTHWEST CORNER OF SAID SOUTHWEST QUARTER BEING LOCATED NORTH 00°55'40" WEST 1331.05 FEET (NORTH 1329.9 MORE OR LESS BY RECORD) FROM THE WEST QUARTER CORNER OF SAID SECTION 14; RUNNING THENCE ALONG SAID SOUTH RIGHT-OF-WAY LINE AND THE NORTH LINE OF SAID SOUTHWEST QUARTER SOUTH 89°15'11" EAST 110.0 FEET; THENCE SOUTH 00°34'24" WEST 100.0 FEET; THENCE SOUTH 89°25'36" EAST 88.54 FEET; THENCE SOUTH 00°34'24" WEST 20.68 FEET; THENCE NORTH 89°08'30" WEST 195.38 FEET TO THE WEST LINE OF SAID NORTHWEST QUARTER; THENCE ALONG SAID WEST LINE NORTH 00°55'40" WEST 120.75 FEET TO THE POINT OF BEGINNING. CONTAINING 40,018 SQUARE FEET.

PARCEL B
 A PART OF THE SOUTHWEST QUARTER OF THE NORTHWEST QUARTER OF SECTION 14, TOWNSHIP 6 NORTH, RANGE 2 WEST, OF THE SALT LAKE BASE AND MERIDIAN. BEGINNING AT A POINT ON THE WEST LINE OF SAID NORTHWEST QUARTER BEING LOCATED NORTH 00°55'40" WEST 1210.31 FEET ALONG SAID WEST LINE FROM THE WEST QUARTER CORNER OF SAID SECTION 14; RUNNING THENCE SOUTH 89°08'30" EAST 135.30 FEET; THENCE SOUTH 00°55'40" EAST 146.30 FEET; THENCE SOUTH 89°47'31" WEST 330.55 FEET TO SAID WEST LINE; THENCE ALONG SAID WEST LINE NORTH 00°55'40" WEST 152.46 FEET TO THE POINT OF BEGINNING. CONTAINING 49,373 SQUARE FEET.

AGREEMENT LINE DESCRIPTION
 A PART OF THE SOUTHWEST QUARTER OF THE NORTHWEST QUARTER OF SECTION 14, TOWNSHIP 6 NORTH, RANGE 2 WEST, OF THE SALT LAKE BASE AND MERIDIAN. BEGINNING AT A POINT ON THE WEST LINE OF SAID NORTHWEST QUARTER BEING LOCATED NORTH 00°55'40" WEST 1057.85 FEET ALONG SAID WEST LINE FROM THE WEST QUARTER CORNER OF SAID SECTION 14; RUNNING THENCE NORTH 89°47'31" EAST 330.55 FEET TO SAID WEST LINE; THENCE ALONG SAID WEST LINE NORTH 00°55'40" WEST 152.46 FEET TO THE POINT OF BEGINNING. CONTAINING 49,373 SQUARE FEET.

Narrative
 The purpose of this survey was to establish and set the property corners of the parcels as shown and described herein. The survey was ordered by Jennifer Wilson. The control used to establish the property corners was the existing Weber County Survey Monumentation surrounding Section 14, T6N, R2W, SLB&M. The basis of bearing is the West line of the Northwest Quarter of said Section which bears North 00°55'40" West Weber County Grid bearing.

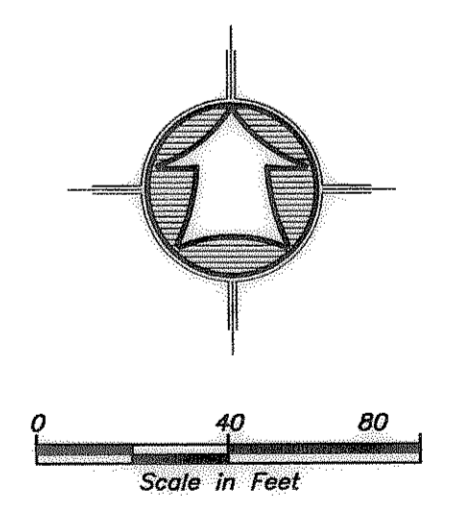
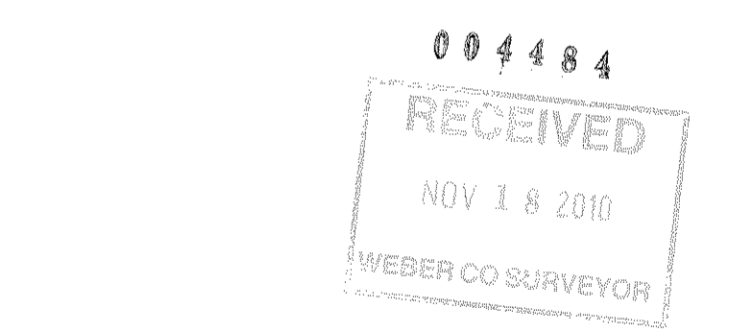

- LEGEND**
- SUBJECT PROPERTY LINE
 - - - ADJOINER PROPERTY LINE
 - CENTERLINE
 - - - DITCH
 - - - FENCE LINE
 - SECTION CORNER
 - FOUND PROPERTY CORNER
 - SET 5/8" REBAR W/ CAP

SURVEY CERTIFICATE

I, K. Greg Hansen, do hereby certify that I am a Registered Land Surveyor, and that I hold Certificate No. 167819 as prescribed by the Laws of the State of Utah, and that I have made and/or Supervised the survey of the property shown and described hereon and that this plat is a true and correct representation of said survey to the best of my knowledge and belief.

K. Greg Hansen,
 R.L.S. No. 167819
 date 10/25/2010

Drawn By: KHW Date: 09/21/10
 Designed By: —
 Checked By: —
 Approved By: —
 Scale: 1"=40'
 Drawing File: 10-3-7AFS.DWG
 JOB NUMBER: 10-3-3-Z4

LOT LINE ADJUSTMENT PLAT FOR
JENNIFER WILSON
 230 SOUTH 2700 WEST
 MARIOTT SLATERVILLE, WEBER COUNTY, UTAH
 A PART OF THE NORTHWEST QUARTER OF SECTION 14,
 TOWNSHIP 6 NORTH, RANGE 2 WEST, S.L.B.& M.

SHEET
1
 OF
1
 SHEETS

HANSEN & ASSOCIATES, INC.
 Consulting Engineers and Land Surveyors
 538 North Main Street, Brigham, Utah 84302
 Visit us at www.hansen.net
 Brigham City, Ogden, UT
 (801) 725-3491 (801) 388-4605 (435) 752-8272

No.	Date	By	Revision
1	09/21/10	Kgh	added parcels 1 - 4