

Parcel No. 1
Linda M. Budge
Containing 1.95 Acres
190140047

Parcel No. 1
As-Surveyed Description

A PART OF THE SOUTHWEST QUARTER OF SECTION 24, TOWNSHIP 7 NORTH, RANGE 2 WEST OF THE SALT LAKE BASE AND MERIDIAN, BEGINNING AT A POINT ON THE SOUTHWESTERLY RIGHT-OF-WAY LINE OF PLEASANT VIEW DRIVE LOCATED NORTH 89°14'59" WEST 793.99 FEET ALONG THE NORTH LINE OF SAID SOUTHWEST QUARTER AND SOUTH 36°30'07" WEST 63.99 FEET FROM THE NORTHEAST CORNER OF SAID SOUTHWEST QUARTER, SAID POINT DESCRIBED OF RECORD AS BEING LOCATED WEST 851.40 FEET AND SOUTH 64° EAST 47.42 FEET AND SOUTHWESTERLY 35 FEET FROM THE NORTHEAST CORNER OF SAID SOUTHWEST QUARTER; RUNNING THENCE SOUTH 36°30'07" WEST 244.99 FEET; THENCE SOUTH 30°16'48" WEST 19.94 FEET; THENCE SOUTH 61°57'51" EAST (SOUTH 64° EAST BY RECORD) 328.90 FEET; THENCE NORTH 33°52'15" EAST 264.32 FEET TO SAID SOUTHWESTERLY RIGHT-OF-WAY LINE; THENCE ALONG SAID RIGHT-OF-WAY LINE THE FOLLOWING TWO (2) COURSES; (1) NORTH 65°19'25" WEST 49.15 FEET; (2) TO THE RIGHT ALONG THE ARC OF A 1984.90 FOOT RADIUS CURVE, A DISTANCE OF 279.27 FEET, CHORD BEARS NORTH 61°17'35" WEST 279.04 FEET TO THE POINT OF BEGINNING. CONTAINING 1.95 ACRES.

(C1)
Δ = 8°03'41"
R = 1984.90'
L = 279.27'
LC = 279.04'
N 61°17'35" W

004486
RECEIVED
NOV 18 2010
WEBER CO SURVEYOR
004486

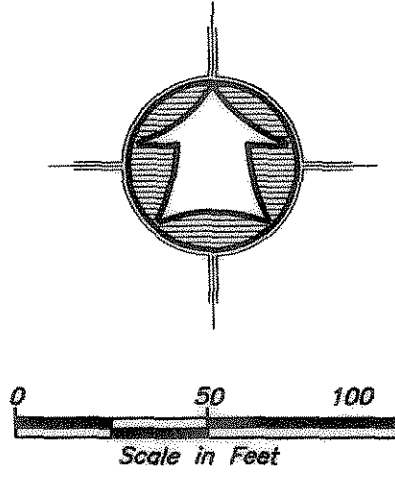

LEGEND

	SUBJECT PROPERTY LINE
	ADJOINER PROPERTY LINE
	CENTERLINE
	DITCH
	FENCE LINE
	SECTION CORNER
	HIGHWAY R-O-W MONUMENT SET 5/8" REBAR W/ CAP

SURVEY CERTIFICATE

I, K. Greg Hansen, do hereby certify that I am a Registered Land Surveyor, and that I hold Certificate No. 167819 as prescribed by the Laws of the State of Utah, and that I have made and/or Supervised the survey of the property shown and described hereon and that this plat is a true and correct representation of said survey to the best of my knowledge and belief.

K. Greg Hansen, date
R.L.S. No. 167819

Narrative
The purpose of this survey was to establish and set the property corners of the parcel as shown and described hereon. The survey was ordered by Linda Budge. The control used to establish the property corners was the existing Weber County Survey Monumentation surrounding Section 24, T7N, R2W, SLB&M. The basis of bearing is the West line of the Southwest Quarter of said Section which bears North 00°50'01" East (Weber County Survey Grid Bearing).

<p>HANSEN & ASSOCIATES, INC. Consulting Engineers and Land Surveyors 538 North Main Street, Brigham, Utah 84302 1/2 City, Utah Brighton, CO (435) 725-3491 (801) 389-4905 (435) 752-8272 www.hanseninc.com</p>	
<p>Drawn By: KGH Date: 08/03/10</p>	<p>Designed By: _____</p>
<p>Checked By: _____</p>	<p>Approved By: _____</p>
<p>Scale: 1"=50'</p>	<p>Drawing File: 10-3-128.DWG</p>
<p>JOB NUMBER: 10-3-128</p>	<p>REVISIONS</p>
<p>PROPERTY SURVEY FOR Linda Budge 1635 West Pleasant View Drive Pleasant View, Weber County, Utah A PART OF THE SOUTHWEST QUARTER SECTION 24, TOWNSHIP 7 NORTH, RANGE 2 WEST, S.L.B.& M.</p>	
<p>SHEET 1</p>	<p>OF 1</p>
<p>SHEETS</p>	