

Raymond Bertoldi
221050007

Megan Timoney
221050003

Kevin Gleaves
Cont. 1.089 Acres
221050002

Ruffhans LLC
221050008

Mark Rubey Trust
221050001

Abbeyon Drive (3750 East)

Nordic Valley Road

Mtn. Eng. Rebar

Mtn. Eng. Rebar

Found & Held 1/2" Rebar

Found & Held 1/2" Rebar

004487
RECEIVED
NOV 18 2010
WEBER CO SURVEYOR
004487

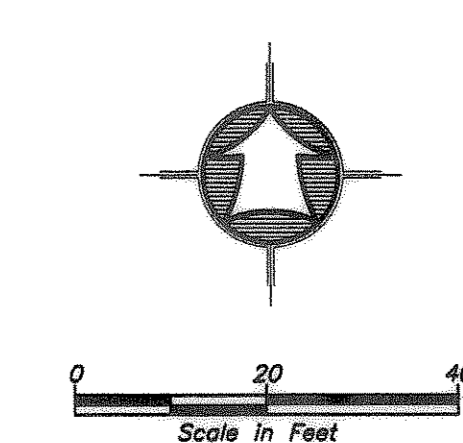

- LEGEND**
- SUBJECT PROPERTY LINE
 - - - LOT LINE
 - - - SUBDIVISION BOUNDARY LINE
 - - - CENTERLINE
 - ⊙ FOUND SURVEY POINT
 - ◆ SECTION CORNER
 - ⊕ STREET MONUMENT
 - ⊙ SET 5/8" REBAR W/ CAP
 - SET LATH & 8" NAIL

SURVEY CERTIFICATE

I, K. Greg Hansen, do hereby certify that I am a Registered Land Surveyor, and that I hold Certificate No. 167819 as prescribed by the Laws of the State of Utah, and that I have made and/or Supervised the survey of the property shown and described hereon and that this plat is a true and correct representation of said survey to the best of my knowledge and belief.

K. Greg Hansen, RLS. No. 167819

 August 17, 2010 date

Narrative

The purpose of this survey was to establish and set the property corners of the parcel as shown and described hereon. The survey was ordered by Kevin Gleaves. The control used to establish the property corners was the existing survey points found within Abbeyon Estates No. 2 subdivision located in the Southeast Quarter of Section 29, T7N, R1E, SLB&M. The basis of bearing is the East line of Lot 6 which has a record bearing of South 01°44'10" West.

As-Surveyed Description

All of Lot 6 of Abbeyon Estates No. 2, Located in the Southeast Quarter of Section 29, Township 7 North, Range 1 East, Salt Lake Base & Meridian, Weber County, Utah.

Curve Data

(C1)
 $\Delta = 2'56''16''$
 $R = 150.11'$
 $L = 7.70$
 $T = 48.93'$

PROPERTY SURVEY FOR
Kevin Gleaves
2876 North 3750 East
Liberty, Weber County, Utah
A part of the Southeast Quarter of Section 29,
Township 7 North, Range 1 East, S.L.B.&M.

Drawn By: CGH Date: 8/12/10
 Designed By: _____
 Checked By: _____
 Approved By: _____
 Scale: 1"=20'
 Drawing File: 10-3-125.DWG
 JOB NUMBER: 10-3-125

HANSEN & ASSOCIATES, INC.
 Consulting Engineers and Land Surveyors
 538 North Main Street, Brigham, Utah 84302
 Visit us at www.hansen.net
 Logan
 Ogden
 (435) 733-3491 (801) 399-6905 (435) 752-8272

RECEIVED
 NOV 18 2010
 WEBER CO SURVEYOR
 004487

SHEET
1
 OF
1
 SHEETS