

004496
 RECEIVED
 DEC 24 2010
 WEBER CO SURVEYOR

As-Surveyed Overall Description:
 A Part of the Northwest Quarter of Section 5, Township 5 North, Range 1 West, Salt Lake Base and Meridian.
 Beginning at a Point on the North Right-of-Way Line of Harris Street Located North 89°23'11" West (North 89°46'20" West By Record) 524.90 Feet Along the South Line of said Northwest Quarter and North 01°21'09" East (North 00°58'00" East By Record) 392.00 Feet and North 89°23'11" West (North 89°46'20" West By Record) 691.00 Feet from the Southeast Corner of said Northwest Quarter and Running Thence North 89°23'11" West (North 89°46'20" West By Record) 837.99 Feet Along said North Right-of-Way Line Parallel and 392.00 Feet Equidistant from said South Line to the East Right-of-Way of Pacific Avenue; Thence North 06°12'39" East 1048.21 Feet (North 05°49'30" East By Record) to a Point of Record being 618.23 Feet from the Intersection of said East Line with the Centerline of 33rd Street; Thence South 89°36'05" East (South 89°59'15" East by record) 357.87 Feet; Thence South 01°24'10" West 543.15 Feet (South 01°01' West 528.03 Feet By Record) to a Point being 893.50 Feet North of the South Line of said Quarter; Thence South 89°23'11" East (South 89°46'20" East By Record) 391.83 Feet Parallel with said South Line; Thence South 01°21'09" West (South 00°58' West By Record) 501.50 Feet to the Point of Beginning. Containing 14.141 Acres.

Narrative
 The purpose of this survey was to create an overall description for the parcels as shown and described hereon. The survey was ordered by Wayne Hamilton of Homeland Vinyl. The control used to establish the property corners was the existing Weber County Survey Monumentation surrounding the Northwest Quarter of Section 5, T5N, R1W, SLB&M and existing Ogden City Street Centerline Monuments. The basis of bearing is the South line of said Quarter Section which bears North 89°23'11" West per the Weber County Surveyor.

Note: The Right-of-Ways shown hereon are ambiguous by record. The distances and calls from certain monuments vary and don't close to the beginning points. The location of the right-of-ways are plotted based on a best fit and practical location. In our opinion, title research of the right-of-ways needs to be done to clarify the discrepancies of record. The determination of ALL right-of-way or easements of record is outside the scope of this project and caution should be used before constructing improvements on the property.

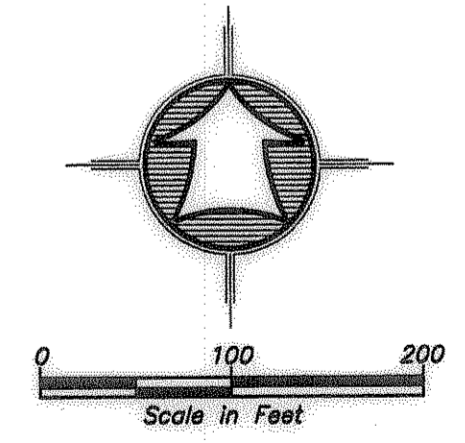

- LEGEND**
- Subject Property Line
 - - - Secondary Property Line
 - Centerline
 - - - Easement/Right-of-Way Line
 - Section Line
 - Fence Line
 - X Section Corner
 - Street Centerline Monument
 - Set 24"x5/8" Rebar with Cap

SURVEY CERTIFICATE
 I, K. Greg Hansen, do hereby certify that I am a Registered Land Surveyor, and that I hold Certificate No. 167819 as prescribed by the Laws of the State of Utah, and that I have made and/or Supervised the survey of the property shown and described hereon and that this plat is a true and correct representation of said survey to the best of my knowledge and belief.

K. Greg Hansen, R.L.S. No. 167819
 date OCT. 25, 2010

PROPERTY SURVEY FOR
Homeland Vinyl
 Harris & Pacific Avenue
 Ogden, Weber County, Ogden
 A Part of the Northwest Quarter of Section 5,
 Township 5 North, Range 1 West, S.L.B.&M.

HANSEN & ASSOCIATES, INC.
 Consulting Engineers and Land Surveyors
 538 North Main Street, Brigham, Utah 84302
 Visit US at www.hansen.net
 Brigham City, Utah (801) 369-4905 (435) 752-8272
 (435) 753-3481

No.	By	Date	Revision

Drawn By: GCH Date: 10-21-10
 Designed By: _____
 Checked By: _____
 Approved By: _____
 Scale: 1"=100'
 Drawing File: 10-3-167.DWG
 JOB NUMBER: 10-3-167

SHEET
1
 OF
1
 SHEETS