



**PARCEL A**

A PART OF THE NORTHEAST QUARTER OF SECTION 7, TOWNSHIP 7 NORTH, RANGE 1 EAST, SALT LAKE BASE AND MERIDIAN.

BEGINNING AT THE NORTHEAST CORNER OF THE WILLSON ESTATES SUBDIVISION SAID POINT BEING IN THE PROJECTION OF THE SOUTH LINE OF WATTS SUBDIVISION BEING LOCATED SOUTH 86°07'30" WEST 1184.76 FEET ALONG THE SOUTH LINE OF SAID QUARTER TO THE EAST RIGHT-OF-WAY OF NORTH FORK ROAD AND NORTH 33°49'24" WEST 1631.29 FEET ALONG SAID RIGHT-OF-WAY AND NORTH 87°19'43" EAST 763.97 FEET FROM THE EAST QUARTER CORNER OF SAID SECTION 7 AND RUNNING THENCE SOUTH 89°42'42" EAST 209.01 FEET ALONG SAID SOUTH LINE AND SAID PROJECTION; THENCE SOUTH 00°27'24" EAST 534.33 FEET TO THE NORTHEASTERLY PERIMETER OF SAID WILLSON ESTATES SUBDIVISION; THENCE ALONG SAID PERIMETER THE FOLLOWING TWO (2) COURSES: (1) SOUTH 86°07'30" WEST 209.37 FEET; (2) NORTH 00°27'24" WEST 549.50 FEET TO THE POINT OF BEGINNING. CONTAINING 2.600 ACRES.

**PARCEL B**

A PART OF THE NORTHEAST QUARTER OF SECTION 7, TOWNSHIP 7 NORTH, RANGE 1 EAST, SALT LAKE BASE AND MERIDIAN.

BEGINNING AT A POINT ON THE SOUTH LINE OF WATTS SUBDIVISION BEING LOCATED SOUTH 86°07'30" WEST 1184.76 FEET ALONG THE SOUTH LINE OF SAID QUARTER TO THE EAST RIGHT-OF-WAY OF NORTH FORK ROAD AND NORTH 33°49'24" WEST 1631.29 FEET ALONG SAID RIGHT-OF-WAY AND NORTH 87°19'43" EAST 763.97 FEET TO THE NORTHEAST CORNER OF SAID SECTION 7 AND RUNNING THENCE SOUTH 89°42'42" EAST 231.37 FEET ALONG SAID SOUTH LINE TO THE COMMON SOUTH CORNER OF SAID WATTS SUBDIVISION AND JOHN MONTGOMERY SUBDIVISION; THENCE SOUTH 89°59'45" EAST 387.21 FEET ALONG SAID SOUTH LINE TO THE INTERSECTION OF SAID SOUTH LINE WITH THE WEST LINE OF CJ MONTGOMERY SUBDIVISION; THENCE ALONG THE PERIMETER OF SAID CJ MONTGOMERY SUBDIVISION THE FOLLOWING TWO (2) COURSES: (1) SOUTH 01°38'34" WEST 321.85 FEET; (2) SOUTH 89°44'24" EAST 18.69 FEET TO THE INTERSECTION WITH SAID SUBDIVISION PERIMETER AND THE WEST LINE OF JOHN MONTGOMERY JR. SUBDIVISION; THENCE ALONG THE PERIMETER OF SAID JOHN MONTGOMERY JR. SUBDIVISION THE FOLLOWING TWO (2) COURSES: (1) SOUTH 00°41'50" WEST 300.00 FEET; (2) SOUTH 89°44'20" EAST 456.65 FEET TO THE INTERSECTION OF THE PROJECTION OF SAID JOHN MONTGOMERY JR. SUBDIVISION AND THE WEST LINE OF STATE HIGHWAY 162 BEING 40.00 FEET FROM THE EAST LINE OF SAID NORTHEAST QUARTER; THENCE SOUTH 00°15'41" WEST 356.56 FEET PARALLEL AND 40.00 FEET EQUIDISTANT FROM SAID EAST QUARTER LINE; THENCE SOUTH 86°07'30" WEST 592.12 FEET TO THE SOUTHEAST CORNER OF SAID WILLSON ESTATES SUBDIVISION; THENCE ALONG THE NORTHEASTERLY PERIMETER OF SAID WILLSON ESTATES SUBDIVISION THE FOLLOWING FOUR (4) COURSES: (1) NORTH 03°52'30" WEST 278.86 FEET; (2) SOUTH 86°07'30" WEST 364.64 FEET; (3) NORTH 00°27'24" WEST 239.47 FEET; (4) SOUTH 86°07'30" WEST 99.99 FEET; THENCE NORTH 00°27'24" WEST 534.33 FEET TO THE POINT OF BEGINNING. CONTAINING 14.951 ACRES.

004499  
**RECEIVED**  
 DEC 24 2010  
 WEBER CO SURVEYOR

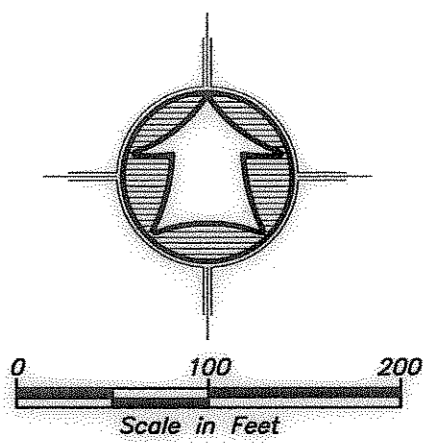

- LEGEND**
- Subject Property Line
  - - - Secondary Property Line
  - Centerline
  - - - Old Property Line
  - Section Line
  - Fence Line
  - Section Corner
  - Set 24"x5/8" Rebar with Cap
  - Found Rebar

**SURVEY CERTIFICATE**

I, K. Greg Hansen, do hereby certify that I am a Registered Land Surveyor, and that I hold Certificate No. 167819 as prescribed by the Laws of the State of Utah, and that I have made and/or Supervised the survey of the property shown and described hereon and that this plat is a true and correct representation of said survey to the best of my knowledge and belief.

K. Greg Hansen, R.L.S. No. 167819  
 date 10/16/2010

**Narrative**

The purpose of this survey was to establish a 2.60 Acre parcel located adjacent to Lot 1 of the Willson Estates Subdivision. The survey was ordered by Brad Willson. This survey constitutes a division of property and should be approved by the local governing entity in compliance with Utah Code 17-27A-605(3). Building permits will not be issued for the parcels shown hereon without approval from Weber County. The control used to establish the property corners was the existing Weber County Survey Monumentation surrounding the Northeast Quarter of Section 7, T7N, R1E, S1B&M. The basis of bearing is the East line of said Quarter Section which bears North 00°15'41" East per the Weber County Surveyor.

PROPERTY SURVEY FOR  
**Brad Willson**  
 5575 North 3100 East  
 Weber County, Utah

A PART OF THE NORTHEAST QUARTER OF SECTION 7, TOWNSHIP 7 NORTH, RANGE 1 EAST, S.L.B.&M.

No.	Date	By

**HANSEN & ASSOCIATES, INC.**  
 Consulting Engineers and Land Surveyors  
 538 North Main Street, Brigham, Utah 84302  
 Visit us at www.hales.net  
 Logan, Ogden, Provo, Salt Lake City  
 (435) 753-3461 (801) 399-4905 (435) 752-8272

Drawn By: CGH Date: 9-20-10  
 Designed By: \_\_\_\_\_  
 Checked By: \_\_\_\_\_  
 Approved By: \_\_\_\_\_  
 Scale: 1"=100'  
 Drawing File: 10-5-146.DWG  
 JOB NUMBER: 10-3-146

SHEET  
**1**  
 OF  
**1**  
 SHEETS