

# FELT SUBDIVISION

A PART OF THE NORTHEAST 1/4 OF SECTION 18,  
TOWNSHIP 7 NORTH, RANGE 1 EAST, SLB&M, U.S. SURVEY  
WEBER COUNTY, UTAH  
JANUARY 2011

SAMUEL AND  
SANDRA DEYOUNG

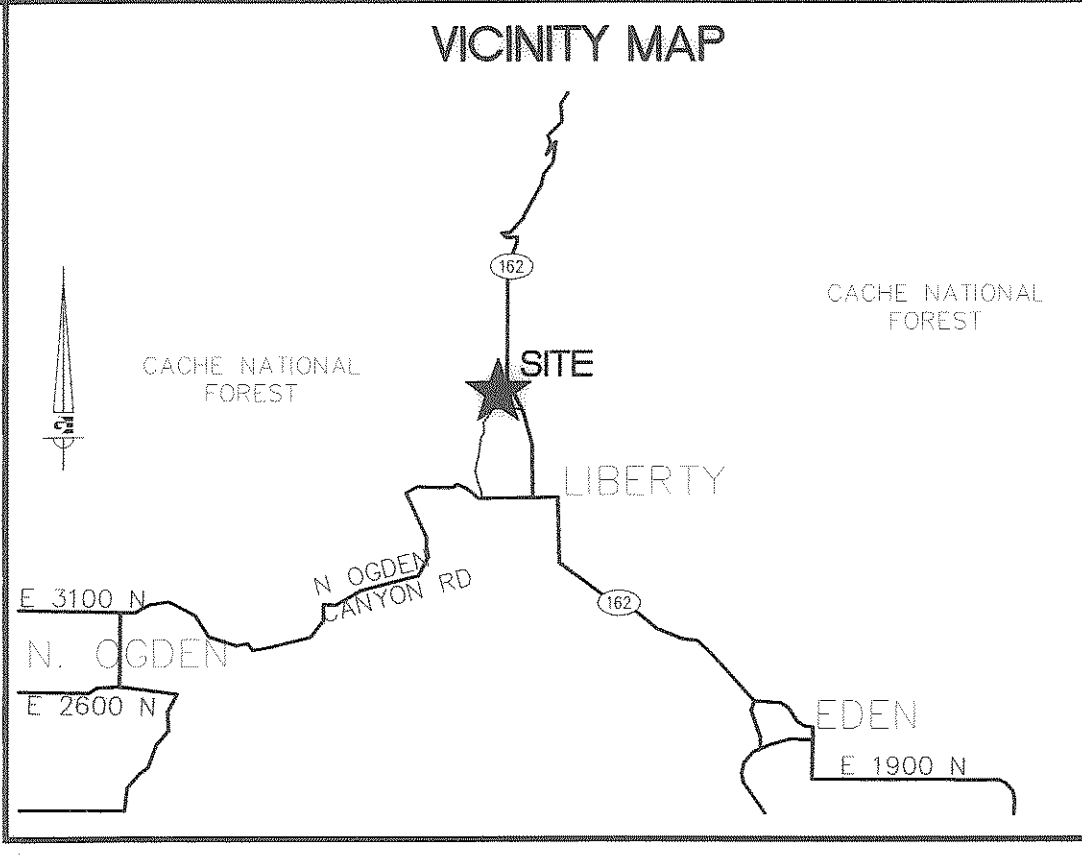
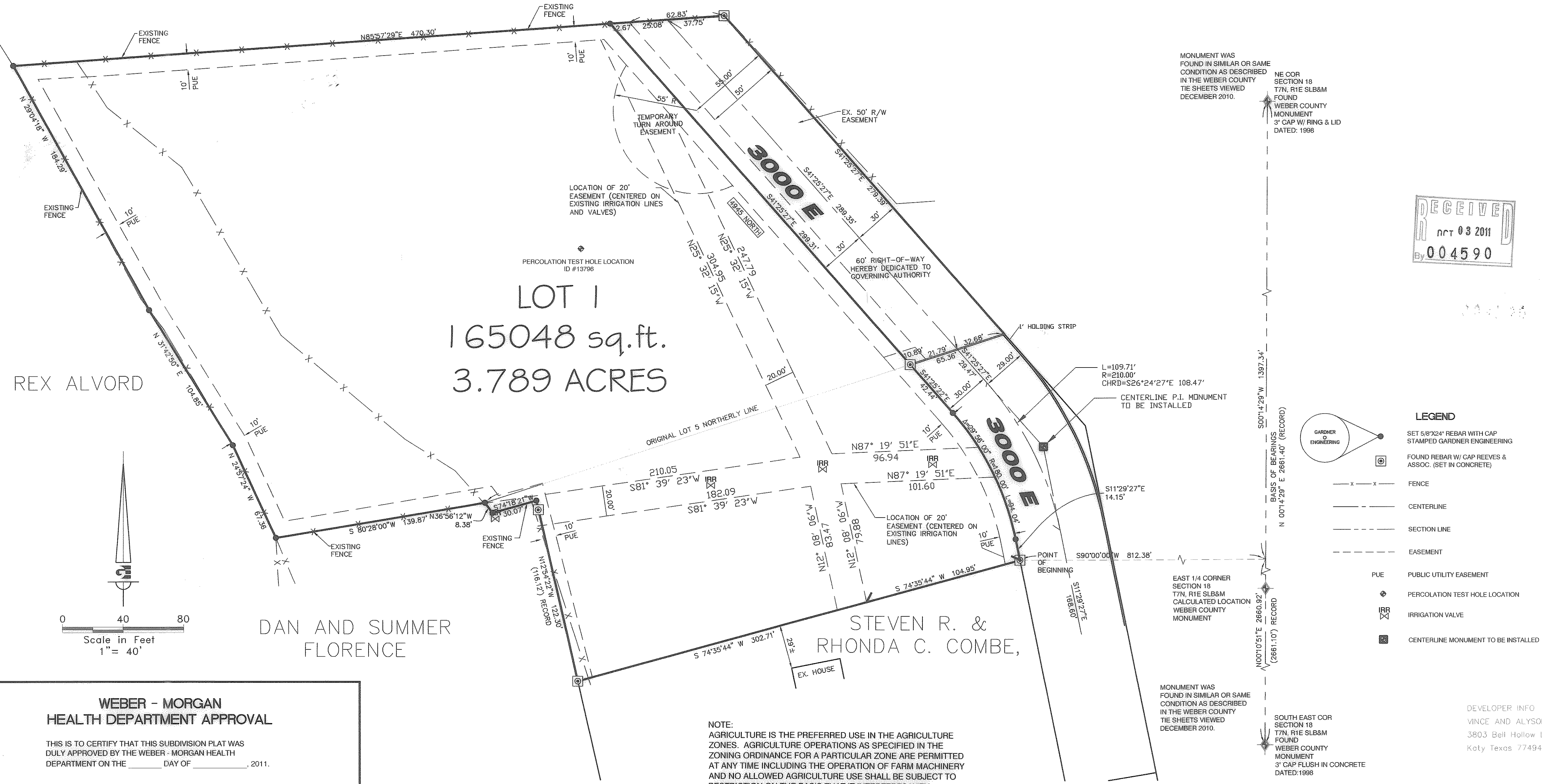

### OVERALL BOUNDARY DESCRIPTION

THAT PORTION OF THE NORTHEAST QUARTER OF SECTION 18, TOWNSHIP 7 NORTH, RANGE 1 EAST, SALT LAKE BASE AND MERIDIAN, LOCATED IN THE UNINCORPORATED AREA OF WEBER COUNTY, STATE OF UTAH, DESCRIBED AS FOLLOWS:

COMMENCING AT THE NORTHEAST CORNER OF SAID SECTION 18; THENCE SOUTH 00°14'29" WEST 1397.34 FEET ALONG THE EASTERLY LINE OF SAID NORTHEAST QUARTER; THENCE SOUTH 90°00'00" WEST 812.38 FEET TO A 5/8" REBAR AND CAP (REEVES AND ASSOCIATES) SET IN CONCRETE AT THE SOUTHEASTERLY CORNER OF SAID LOT 5 AND THE POINT OF BEGINNING;

THENCE SOUTH 74°35'44" WEST 302.71 FEET TO A 5/8" REBAR AND CAP (REEVES AND ASSOCIATES) SET IN CONCRETE AT THE SOUTHWESTERLY CORNER OF SAID LOT 5;

THENCE NORTH 12°54'17" WEST 122.30 FEET;

THENCE SOUTH 74°18'21" WEST 30.07 FEET ALONG AN EXISTING WIRE FENCE TO A FENCE CORNER POST;

THENCE NORTH 36°59'12" WEST 8.38 FEET ALONG AN EXISTING WIRE FENCE TO A 5/8" REBAR AND CAP (GARDNER ENGINEERING);

THENCE ALONG AN EXISTING WIRE FENCE SOUTH 80°28'00" WEST 139.87 FEET;

THENCE ALONG AN EXISTING WIRE FENCE THE FOLLOWING THREE COURSES

NORTH 24°57'24" WEST 87.36 FEET;  
NORTH 31°42'50" WEST 104.85 FEET;  
NORTH 29°04'18" WEST 184.28 FEET;

THENCE ALONG AN EXISTING WIRE FENCE NORTH 85°57'29" EAST 470.30 FEET TO A 5/8" REBAR AND CAP (CAP ILLEGIBLE) SET IN CONCRETE;

THENCE SOUTH 41°25'27" EAST 279.38 FEET;

THENCE SOUTH 71°58'29" WEST 65.36 FEET TO A 5/8" REBAR AND CAP (REEVES AND ASSOCIATES) SET IN CONCRETE AT THE NORTHEASTERLY CORNER OF SAID LOT 5;

THENCE SOUTH 41°25'27" EAST 42.44 FEET TO THE BEGINNING OF A CURVE CONCAVE SOUTH-WESTERLY HAVING A RADIUS OF 180.00 FEET;

THENCE SOUTHEASTERLY 94.04 FEET ALONG SAID CURVE THROUGH A CENTRAL ANGLE OF 29°59'00";

THENCE SOUTH 11°29'27" EAST 14.15 FEET TO THE POINT OF BEGINNING.

CONTAINING: 182,414.54 S.F. OR 4.19 ACRES, MORE OR LESS.

SUBJECT TO: ALL EASEMENTS AND RIGHTS-OF-WAY OF RECORD.

### SURVEY NARRATIVE

THIS SURVEY WAS REQUESTED BY ALYSON FELT FOR THE PURPOSE OF LOCATING THE BOUNDARIES OF THE PARCELS OF LAND KNOWN BY ASSESSOR PARCEL NUMBERS 22-008-0020 AND 22-174-0002. AT THE TIME OF THIS SURVEY, MRS. FELT WAS UNDER CONTRACT TO PURCHASE THE PROPERTY FROM JOHNSON FAMILY, WHO WERE AWARE OF THE SURVEY. THE PURPOSE OF THIS SURVEY WAS ALSO TO COMBINE BOTH PARCELS INTO ONE LOT WHICH IS IN COMPLIANCE WITH CURRENT COUNTY ORDINANCES.

MONUMENTS WERE FOUND IN THEIR RECORD LOCATION AS SHOWN ON THIS PLAT.

THE SOUTHERN AND WESTERN BOUNDARY LINES OF THE ORIGINAL PARCEL 22-008-0020 WERE ESTABLISHED BY HOLDING THE EXISTING BARB WIRE FENCE LINES. THE BARB WIRE FENCE HAS BEEN ACCEPTED BY THE PREVIOUS LAND OWNER AND THE ADJOINING LAND OWNER. AS PER A DISCUSSION BETWEEN SAMUEL D. YOUNG AND MYSELF, IT WAS APPARENT THAT THE FENCES ALONG THE NORTH, WEST AND SOUTH LINES OF SAID ORIGINAL PARCEL HAVE HISTORICALLY BEEN ACCEPTED BETWEEN ALL PARTIES. THAT BEING SAID THEIR WILL BE BOUNDARY LINE AGREEMENTS RECORDED BETWEEN THE ADJOINING LAND OWNERS WHERE NEEDED. THE AGREEMENTS WILL FURTHER AID IN THE ELIMINATION OF THE AMBIGUITIES CREATED BY THE HISTORIC DEEDS.

THE LOCATION OF THE IRRIGATION EASEMENT WAS DETERMINED FROM FIELD MEASUREMENTS OF THE EXISTING IRRIGATION VALVES/RISERS AND AS DELINEATED BY THE LAND OWNER AND THE IRRIGATION COMPANY. THE EASEMENT IS 20' WIDE AND IS CENTERED ON THE EXISTING UTILITIES.

### SURVEYOR'S CERTIFICATE

I, TRAVIS J. DALEY, DO HEREBY CERTIFY THAT I AM A LICENSED PROFESSIONAL LAND SURVEYOR IN THE STATE OF UTAH AND THAT I HOLD CERTIFICATE NO. 6387184 IN ACCORDANCE WITH TITLE 58, CHAPTER 22, OF THE PROFESSIONAL ENGINEERS AND LAND SURVEYORS ACT. I FURTHER CERTIFY THAT BY AUTHORITY OF THE OWNERS I HAVE COMPLETED A SURVEY OF THE PROPERTY DESCRIBED ON THIS RECORD OF SURVEY PLAT IN ACCORDANCE WITH SECTION 17-23-17 AND HAVE VERIFIED ALL MEASUREMENTS; THAT THE REFERENCE MONUMENTS SHOWN ON THIS PLAT ARE LOCATED AS INDICATED AND ARE SUFFICIENT TO RETRACE OR RE-ESTABLISH THE BOUNDARIES OF THIS PLAT; AND THAT THE INFORMATION SHOWN HEREIN IS SUFFICIENT TO ACCURATELY RE-ESTABLISH THE LATERAL BOUNDARIES OF THE HEREIN DESCRIBED TRACT OF REAL PROPERTY; AND THAT THIS PLAT OF

**FELT SUBDIVISION**

IN WEBER COUNTY, UTAH, HAS BEEN DRAWN CORRECTLY TO THE DESIGNATED SCALE AND IS A TRUE AND CORRECT REPRESENTATION OF THE HEREIN DESCRIBED LANDS INCLUDED IN SAID SUBDIVISION, BASED UPON DATA COMPILED FROM RECORDS IN THE WEBER COUNTY RECORDERS OFFICE. I FURTHER CERTIFY THAT THE REQUIREMENTS OF ALL APPLICABLE STATUTES AND ORDINANCES OF WEBER COUNTY CONCERNING ZONING REQUIREMENTS REGARDING LOT MEASUREMENTS HAVE BEEN COMPLIED WITH.

SIGNED THIS 21<sup>ST</sup> DAY OF SEPTEMBER, 2011.

### OWNER'S SUBDIVISION DEDICATION

WE THE UNDERSIGNED OWNERS OF THE HEREIN DESCRIBED TRACT OF LAND DO HEREBY SET APART AND SUBDIVIDE THE SAME INTO LOTS AND STREETS AS SHOWN HEREON AND NAME SAID TRACT

**FELT SUBDIVISION**

AND DO HEREBY DEDICATE TO PUBLIC USE ALL THOSE PARTS OR PORTIONS OF SAID TRACT OF LAND DESIGNATED AS STREETS, THE SAME TO BE USED AS PUBLIC THOROUGHFARES AND ALSO GRANT AND DEDICATE A PERPETUAL RIGHT AND EASEMENT OVER, UPON AND UNDER THE LANDS DESIGNATED AS PUBLIC UTILITY AND DRAINAGE EASEMENTS, THE SAME TO BE USED FOR THE INSTALLATION, MAINTENANCE AND OPERATION OF PUBLIC UTILITY SERVICE LINES, STORM DRAINAGE FACILITIES OR FOR THE PERPETUAL PRESERVATION OF WATER DRAINAGE CHANNELS IN THEIR NATURAL STATE WHICH EVER IS APPLICABLE AS MAY BE AUTHORIZED BY GOVERNING AUTHORITY WITH NO BUILDING OR STRUCTURES BEING ERRECTED WITHIN SUCH EASEMENTS.

SIGNED THIS 29<sup>TH</sup> DAY OF Sept, 2011.

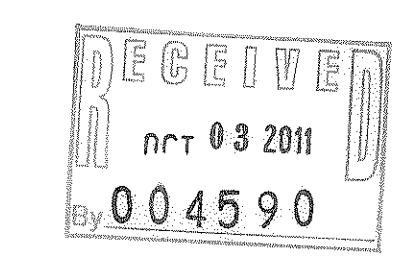
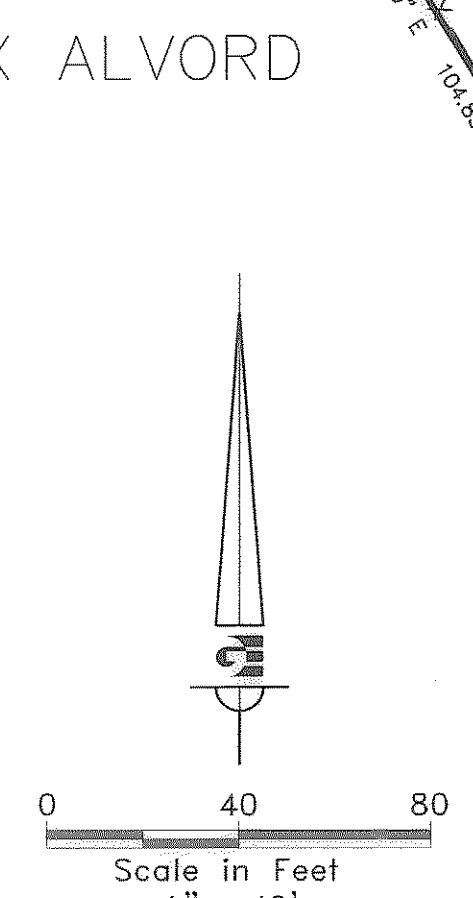

- ### LEGEND
- SET 5/8" X 24" REBAR WITH CAP STAMPED GARDNER ENGINEERING
  - FOUND REBAR W/ CAP REEVES & ASSOC. (SET IN CONCRETE)
  - FENCE
  - CENTERLINE
  - SECTION LINE
  - EASEMENT
  - PUE PUBLIC UTILITY EASEMENT
  - PERCOLATION TEST HOLE LOCATION
  - IRRIGATION VALVE
  - CENTERLINE MONUMENT TO BE INSTALLED

MONUMENT WAS FOUND IN SIMILAR OR SAME CONDITION AS DESCRIBED IN THE WEBER COUNTY RECORDS THE SHEETS VIEWED DECEMBER 2010.

NE COR SECTION 18 T7N, R1E SLB&M FOUND WEBER COUNTY MONUMENT 3" CAP W/ RING & LID DATED: 1998

MONUMENT WAS FOUND IN SIMILAR OR SAME CONDITION AS DESCRIBED IN THE WEBER COUNTY RECORDS THE SHEETS VIEWED DECEMBER 2010.

SOUTH EAST COR SECTION 18 T7N, R1E SLB&M FOUND WEBER COUNTY MONUMENT 3" CAP FLUSH IN CONCRETE DATED: 1998

NOTE: AGRICULTURE IS THE PREFERRED USE IN THE AGRICULTURE ZONES. AGRICULTURE OPERATIONS AS SPECIFIED IN THE ZONING ORDINANCE FOR A PARTICULAR ZONE ARE PERMITTED AT ANY TIME INCLUDING THE OPERATION OF FARM MACHINERY AND NO ALLOWED AGRICULTURE USE SHALL BE SUBJECT TO RESTRICTION ON THE BASIS THAT IT INTERFERES WITH ACTIVITIES OF FUTURE RESIDENTS OF THIS SUBDIVISION.

### WEBER - MORGAN HEALTH DEPARTMENT APPROVAL

THIS IS TO CERTIFY THAT THIS SUBDIVISION PLAT WAS DULY APPROVED BY THE WEBER - MORGAN HEALTH DEPARTMENT ON THE \_\_\_\_\_ DAY OF \_\_\_\_\_, 2011.

\_\_\_\_\_  
SIGNATURE

### WEBER COUNTY PLANNING COMMISSION APPROVAL

THIS IS TO CERTIFY THAT THIS SUBDIVISION PLAT WAS DULY APPROVED BY THE WEBER COUNTY PLANNING COMMISSION ON THE \_\_\_\_\_ DAY OF \_\_\_\_\_, 2011.

\_\_\_\_\_  
CHAIRMAN, WEBER COUNTY PLANNING COMMISSION

### WEBER COUNTY ATTORNEY

I HAVE EXAMINED THE FINANCIAL GUARANTEE AND OTHER DOCUMENTS ASSOCIATED WITH THIS SUBDIVISION PLAT AND IN MY OPINION THEY CONFORM WITH THE COUNTY ORDINANCE APPLICABLE THERETO AND NOW IN FORCE AND EFFECT.

SIGNED THIS \_\_\_\_\_ DAY OF \_\_\_\_\_, 2011.

\_\_\_\_\_  
SIGNATURE

### WEBER COUNTY SURVEYOR

I HEREBY CERTIFY THAT THE WEBER COUNTY SURVEYOR'S OFFICE HAS REVIEWED THIS PLAT FOR MATHEMATICAL CORRECTNESS, SECTION CORNER DATA, AND FOR HARMONY WITH LINES AND MONUMENTS ON RECORD IN COUNTY OFFICES. THE APPROVAL OF THIS PLAT BY THE WEBER COUNTY SURVEYOR DOES NOT RELIEVE THE LICENSED LAND SURVEYOR WHO EXECUTED THIS PLAT FROM THE RESPONSIBILITIES AND/OR LIABILITIES ASSOCIATED THEREWITH.

SIGNED THIS \_\_\_\_\_ DAY OF \_\_\_\_\_, 2011.

\_\_\_\_\_  
SIGNATURE

### WEBER COUNTY ENGINEER

I HEREBY CERTIFY THAT THE REQUIRED PUBLIC IMPROVEMENT STANDARDS AND DRAWINGS FOR THIS SUBDIVISION CONFORM WITH COUNTY STANDARDS AND THE AMOUNT OF THE FINANCIAL GUARANTEE IS SUFFICIENT FOR THE INSTALLATION OF THESE IMPROVEMENTS.

SIGNED THIS \_\_\_\_\_ DAY OF \_\_\_\_\_, 2011.

\_\_\_\_\_  
SIGNATURE

### WEBER COUNTY COMMISSION ACCEPTANCE

THIS IS TO CERTIFY THAT THIS SUBDIVISION PLAT, THE DEDICATION OF STREETS AND OTHER PUBLIC WAYS AND FINANCIAL GUARANTEE OF PUBLIC IMPROVEMENTS ASSOCIATED WITH THIS SUBDIVISION, THEREON ARE HEREBY APPROVED AND ACCEPTED BY THE COMMISSIONERS OF WEBER COUNTY, UTAH

THIS \_\_\_\_\_ DAY OF \_\_\_\_\_, 2011.

\_\_\_\_\_  
CHAIRMAN, WEBER COUNTY COMMISSION

TITLE: \_\_\_\_\_

ATTEST: \_\_\_\_\_

### ACKNOWLEDGMENT

STATE OF UTAH )  
COUNTY OF WEBER ) SS

ON THIS 29<sup>TH</sup> DAY OF Sept, 2011,

PERSONALLY APPEARED BEFORE ME, Alyson C. Felt AND \_\_\_\_\_ AND \_\_\_\_\_ THE SIGNER OF THE ABOVE OWNERS DEDICATION, WHO DULY ACKNOWLEDGED TO ME HE SIGNED IT FREELY AND VOLUNTARILY AND FOR THE PURPOSES THEREIN MENTIONED.

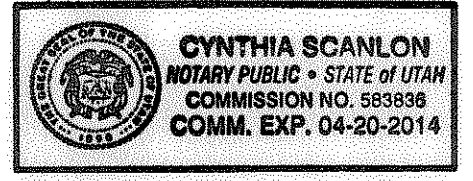

\_\_\_\_\_  
NOTARY PUBLIC

Prepared By: \_\_\_\_\_

**Gardner Engineering**

- PLANNING
- CIVIL ENGINEERING
- LAND SURVEYING
- LANDSCAPE ARCHITECTURE
- ALTERNATIVE ENERGY

5875 South Adams Ave. Parkway, Suite 200 \* Ogden, UT 84405 \* Phone (801) 476 0202 \* Fax (801) 476-0066

www.gardnerengineering.net

COUNTY RECORDER

ENTRY NO. \_\_\_\_\_

FEE PAID \_\_\_\_\_ FILED FOR RECORD

AND RECORDED \_\_\_\_\_

AT \_\_\_\_\_ IN BOOK \_\_\_\_\_

OF OFFICIAL RECORDS, PAGE \_\_\_\_\_

RECORDED FOR \_\_\_\_\_

COUNTY RECORDER \_\_\_\_\_

BY: \_\_\_\_\_ DEPUTY.