

NORTH OGDEN IRRIGATION COMPANY
NOTICE OF INTEREST OF CANAL PROPERTY EASEMENT

PLEASE TAKE NOTICE that the North Ogden Irrigation Company, a Utah corporation (the "Company"), claims prescriptive easement rights to certain real property in Weber County, Utah, for ownership, use, operation and maintenance of a canal, roadway and related water delivery facilities. Said canal property has been in use for the delivery of water for far in excess of the 20-year prescriptive use period. Said canal has been continuously operated and maintained in its present location since the year 1875. The description of said canal is as follows:

SEE DESCRIPTIONS

In certain areas the Company has acquired fee title to the North Ogden Canal property or acquired easements by deed or grant. Along the remainder of said canal alignment, the Company claims prescriptive easement rights that were acquired by continuous uninterrupted adverse use. The prescriptive easement for the North Ogden Canal and adjacent roadway encompasses the entire easement as described.

The Company claims through prescriptive use the exclusive right to the unobstructed use and occupation of the described easement. FENCES ARE NOT PERMITTED WITHIN THE NORTH OGDEN CANAL PROPERTY. Permanent or temporary structures (other than fences) that encroach within the prescriptive easement property may be permitted by written agreement with the Company where the same will not unreasonably interfere with the safe use, operation and maintenance of the North Ogden Canal.

Dated this 17th Day of May, 2012

NORTH OGDEN IRRIGATION COMPANY

By: *Terel H. Grimley*

Terel H. Grimley, President

Description A:

A part of the Northeast Quarter of Section 23 and part of the Southeast Quarter of Section 14, Township 7 North, Range 2 West, Salt Lake Base and Meridian, and being described as follows:

This description describes the centerline of the existing canal. The typical minimum necessary distance to maintain and operate the canal is 7 feet easterly from the easterly top of the canal bank and 20 feet westerly from the westerly top of the canal bank.

Beginning at a point on the Section line said point being S 00°50'12" W 855.74 feet from the Northeast Corner of said Section 23 and following the center line of the North Ogden Canal the following 9 courses:

N 43°37'46" W 444.71 feet; thence
N 61°18'54" W 127.66 feet; thence
N 62°10'25" W 193.40 feet; thence
N 34°12'30" W 178.81 feet; thence
N 45°20'31" W 216.51 feet; thence
N 49°38'03" W 149.20 feet to the Section line; thence
N 49°38'03" W 106.46 feet; thence
N 60°19'58" W 62.94 feet; thence
S 74°04'33" W 55.21 feet to the east boundary line of the Union Pacific Railroad Right-Of-Way

Description B:

A part of part of the Northwest Quarter, Southwest Quarter, and Southeast Quarter of Section 24, Township 7 North, Range 2 West, Salt Lake Base and Meridian, as shown on State of Utah State Road Commission plans for project NS-561(1) and being described as follows:

Beginning at a point on the Section line and on the Southwesterly Right-Of-Way line of Pleasant View Drive said point being S 00°50'12" W 834.21 feet from the Northwest Corner of said Section 24 thence as follows:

S 43°29'42" E 2139.91 feet along the Southwesterly Right-Of-Way line of Pleasant View Drive to a curve to the Left; thence
Southeasterly 723.17 feet along said curve and the Southwesterly Right-Of-Way line of Pleasant View Drive (R=1949.86', T=365.79', CH=719.03, CHB=S 54°07'12" E); thence
S 64°44'42" E 1047.61 feet along the Southerly Right-Of-Way line of Pleasant View Drive to a curve to the Right; thence
Southeasterly 853.32 feet along said curve and the Southwesterly Right-Of-Way line of Pleasant View Drive (R=5689.58', T=427.46', CH=852.52', CHB=S 60°26'55" E); thence
S 33°50'53" W 35.00 feet to a curve to the Left; thence
Northwesterly 848.07 feet along said curve and the Southwesterly Right-Of-Way line of Pleasant View Drive (R=5654.58', T=424.83', CH=847.28', CHB=N 60°26'55" W); thence
N 64°44'42" W 414.30 feet; thence
N 25°15'18" E 10.00 feet; thence
N 64°44'42" W 55.00 feet; thence
N 25°15'18" E 4.00 feet; thence
N 64°44'42" W 60.00 feet; thence
S 25°15'18" W 14.00 feet; thence
N 64°44'42" W 518.31 feet to a curve to the Right; thence
Northwesterly 595.17 feet along said curve and the Southwesterly Right-Of-Way line of Pleasant View Drive (R=1984.86', T=299.84', CH=592.95', CHB=N 56°09'08" W); thence
N 42°28'07" E 10.00 feet to a curve to the Right; thence
Northwesterly 130.29 feet along said curve and the Southwesterly Right-Of-Way line of Pleasant View Drive (R=1974.86', T=65.17', CH=130.26', CHB=N 45°40'29" W); thence
S 46°12'55" W 10.00 feet to a curve to the Right; thence
Northwesterly 10.03 feet along said curve and the Southwesterly Right-Of-Way line of Pleasant View Drive (R=1984.86', T=5.01', CH=10.03', CHB=N 43°38'24" W); thence
N 43°29'42" W 1913.35 feet; thence
N 46°30'18" E 10.00 feet; thence
N 43°29'42" W 80.00 feet; thence
S 46°30'18" W 10.00 feet; thence
N 43°29'42" W 110.74 feet to the Section line; thence
N 00°50'12" E 50.08 feet along the Section line to the Point of Beginning.

Description C:

A part of the Southeast Quarter of Section 24, Township 7 North, Range 2 West, Salt Lake Base and Meridian, and being described as follows:

This description describes the centerline of the existing canal. The typical minimum necessary distance to maintain and operate the canal is 7 feet easterly from the easterly top of the canal bank and 20 feet westerly from the westerly top of the canal bank.

Beginning at a point on the northwesterly boundary line of Country Fields Phase No. 1 said point being N 00°48'35" E 346.95 feet and West 354.46 feet from the Southeast Corner of said Section 24 and following the center line of the North Ogden Canal the following 7 courses:

N 28°37'50" W 118.30 feet; thence
N 37°56'28" W 95.41 feet; thence
N 44°41'02" W 126.34 feet; thence
N 33°19'00" W 207.61 feet; thence
N 27°27'00" W 101.43 feet; thence
N 47°09'44" W 101.90 feet; thence
N 36°34'11" W 405.36 feet to the southeasterly boundary line of Lot 1 Westview Subdivision Phase 1

Description D:

A part of the Northeast Quarter of Section 25 and part of the Southeast Quarter of Section 24, Township 7 North, Range 2 West, Salt Lake Base and Meridian, and being described as follows:

This description describes the centerline of the existing canal. The typical minimum necessary distance to maintain and operate the canal is 7 feet easterly from the easterly top of the canal bank and 20 feet westerly from the westerly top of the canal bank.

Beginning at a point on the Section line said point being S 00°42'39" W 193.19 feet from the Southeast Corner of said Section 24 and following the center line of the North Ogden Canal the following 3 courses:

N 48°06'17" W 64.89 feet; thence
S 42°29'52" W 88.14 feet; thence
N 36°10'21" W 159.89 feet to the southeasterly boundary line of Country Fields Phase No. 1

Description E:

A part of the Northwest Quarter of Section 30, Township 7 North, Range 1 West, Salt Lake Base and Meridian, and being described as follows:

This description describes the centerline of the existing canal. The typical minimum necessary distance to maintain and operate the canal is 7 feet easterly from the easterly top of the canal bank and 20 feet westerly from the westerly top of the canal bank.

Beginning at a point on the Section line said point being S 00°42'39" W 193.19 feet from the Northwest Corner of said Section 30 and following the center line of the North Ogden Canal the following 15 courses:

S 48°06'17" E 252.12 feet; thence
S 48°21'05" E 71.25 feet; thence
S 52°13'38" E 150.25 feet; thence
S 58°00'40" E 497.31 feet; thence
S 49°32'33" E 73.35 feet; thence
S 54°59'25" E 100.97 feet; thence
S 73°26'09" E 103.76 feet; thence
S 76°36'49" E 88.53 feet; thence
S 83°07'06" E 163.57 feet; thence
N 79°52'13" E 253.94 feet; thence
S 88°44'55" E 114.93 feet; thence
S 80°27'10" E 204.05 feet; thence
S 70°41'46" E 77.39 feet; thence
S 61°34'54" E 53.47 feet; thence
S 59°27'31" E 222.11 feet to the northwesterly boundary line of Fox Hollow at Pleasant View - Phase 1

Description F:

A part of the Northeast Quarter of Section 30, Township 7 North, Range 1 West, Salt Lake Base and Meridian, and being described as follows:

This description describes the centerline of the existing canal. The typical minimum necessary distance to maintain and operate the canal is 7 feet easterly from the easterly top of the canal bank and 20 feet westerly from the westerly top of the canal bank.

Beginning at a point on the northwesterly boundary line of Shady Springs Estates said point being N 89°31'15" W 1040.87 feet and North 785.80 feet from the east Quarter Corner of said Section 30 and following the center line of the North Ogden Canal the following 5 courses:

N 71°51'41" W 471.38 feet; thence
N 69°51'28" W 349.07 feet; thence
N 62°01'46" W 129.27 feet; thence
N 55°32'04" W 109.21 feet; thence
N 63°37'39" W 78.80 feet to the southeasterly boundary line Mountain Meadow Estates Subdivision Plat 2.

Description G:

A part of the Northeast Quarter of Section 30, Township 7 North, Range 1 West, Salt Lake Base and Meridian, and being described as follows:

This description describes the centerline of the existing canal. The typical minimum necessary distance to maintain and operate the canal is 7 feet easterly from the easterly top of the canal bank and 20 feet westerly from the westerly top of the canal bank.

Beginning at a point on the northwesterly boundary line of Country Fields Phase No. 1 said point being S 00°58'26" W 2075.58 feet and West 385.22 feet from the Northeast Corner of said Section 30 and following the center line of the North Ogden Canal the following 3 courses:

S 76°10'20" W 114.15 feet; thence
S 84°23'24" W 104.69 feet; thence
S 75°53'25" W 65.09 feet to the southeasterly boundary line of Shady Springs Estates

Description H:

A part of the Northeast Quarter of Section 30, Township 7 North, Range 1 West, Salt Lake Base and Meridian, as shown on State of Utah State Road Commission plans for project NS-561(1) and being described as follows:

Beginning at a point on the Section line and on the Southwesterly Right-Of-Way line of Pleasant View Drive said point being S 00°58'26" W 2372.42 feet from the Northeast Corner of said Section 30 thence as follows:

S 00°58'26" W 45.09 feet along the section line; thence
N 49°56'30" W 528.18 feet; thence
N 75°00'00" E 42.70 feet to the Southwesterly Right-Of-Way line of Pleasant View Drive; thence
S 49°56'30" E 475.30 feet along Southwesterly Right-Of-Way line of Pleasant View Drive to the Point of Beginning.

Narrative:

Basis of bearing is based on the Weber County bearing sheets, section corners found for this survey are West Quarter, and the Southwest Corner of Section 24, Township 7 North, Range 2 West and the South Quarter, and the Northeast Corner of Section 30, Township 7 North, Range 1 West. This survey was requested by the North Ogden Canal Company to locate and map their canal, all other parcels are shown for reference only.

SURVEYOR'S CERTIFICATE

I, David D. Strong, do hereby certify that I am a Professional Land Surveyor and that I hold License No. 5331568 in accordance with Title 58, Chapter 22 of the Professional Engineers and Land Surveyors Licensing Act, have completed a survey of the property shown and described hereon and in accordance with Section 17-23-17. No survey was performed on adjoining parcels they are shown for reference only.

David D. Strong
DAVID D. STRONG, PLS

5/24/2012
Date

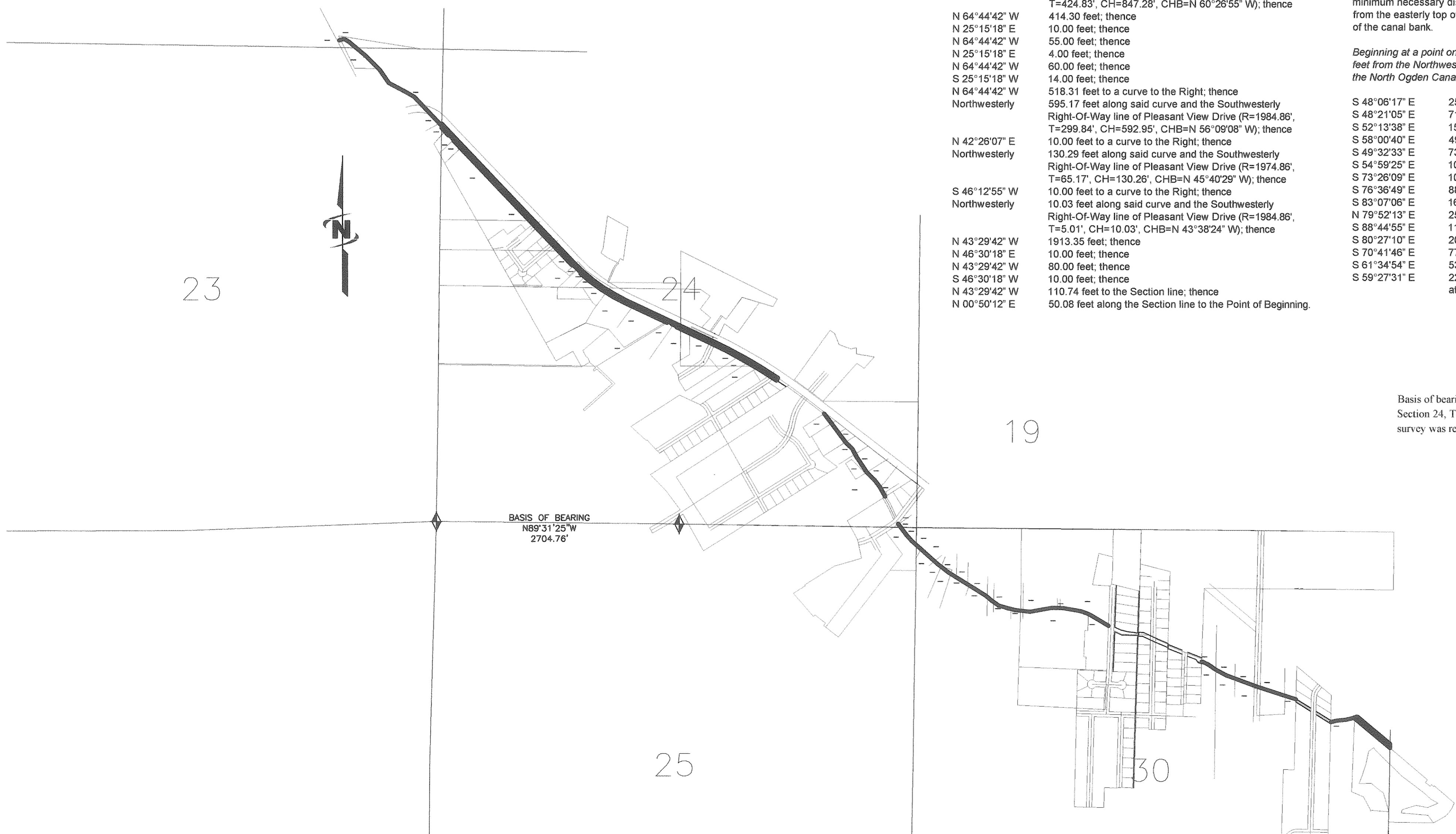
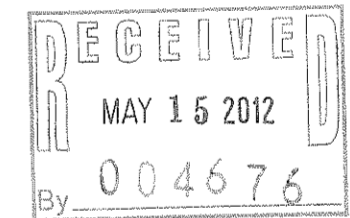
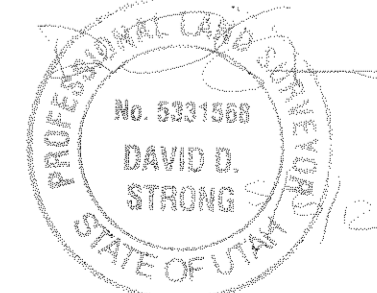

JUB
Engineers • Surveyors • Planners
J-U-B ENGINEERS, Inc.
466 North 900 West
Kaysville, Utah 84037
Phone: 801.547.0393
Fax: 801.547.0397
www.jub.com

NO.	DESCRIPTION	BY	DATE

THIS DOCUMENT, AND THE IDEAS AND DESIGNS INCORPORATED HEREIN, AS AN INSTRUMENT OF PROFESSIONAL SERVICE, IS THE WHOLE OR PART, FOR ANY OTHER PROJECT WITHOUT THE EXPRESS WRITTEN AUTHORIZATION OF J-U-B ENGINEERS, Inc.

**NORTH OGDEN CANAL
RIGHT-OF-WAY PLAT**

CAD FILE: NORTH OGDEN CANAL_A
PROJ #: PMPROJECT #5507060
DRAWN BY: DDS/JDM
DESIGN BY:
CHECKED BY: DDS
SCALE OF SHEET
HOR SCALE: AS NOTED
VER SCALE: AS NOTED
LAST UPDATED: 5/7/2012
SHEET
0



Engineers • Surveyors • Planners

J-U-B ENGINEERS, Inc.
466 North 900 West
Kaysville, Utah 84037

Phone: 801.547.0393
Fax: 801.547.0397
www.jub.com

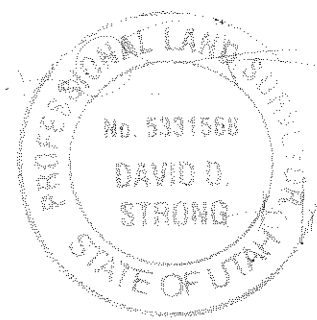

REUSE OF DRAWINGS
THIS DOCUMENT, AND THE IDEAS AND DESIGNS INCORPORATED
HEREIN, AS AN INSTRUMENT OF PROFESSIONAL SERVICE, IS THE
PROPERTY OF JUB ENGINEERS, Inc. AND IS NOT TO BE USED
WITHOUT THE WRITTEN AUTHORIZATION OF JUB ENGINEERS, Inc.

NO.	REVISION	DESCRIPTION	BY	DATE

NORTH OGDEN CANAL
NORTH OGDEN IRRIGATION COMPANY

RIGHT-OF-WAY PLAT

CAD FILE: NORTH OGDEN CANAL_A.DWG
PROJ #: PMPROJECT #5507060
DRAWN BY: DDISUDM
DESIGN BY:
CHECKED BY: DDS
SCALE OF SHEET
HOR SCALE: AS NOTED
VER SCALE: AS NOTED
LAST UPDATED: 5/7/2012

SHEET
1

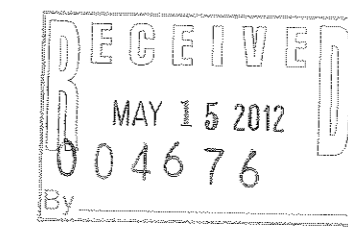
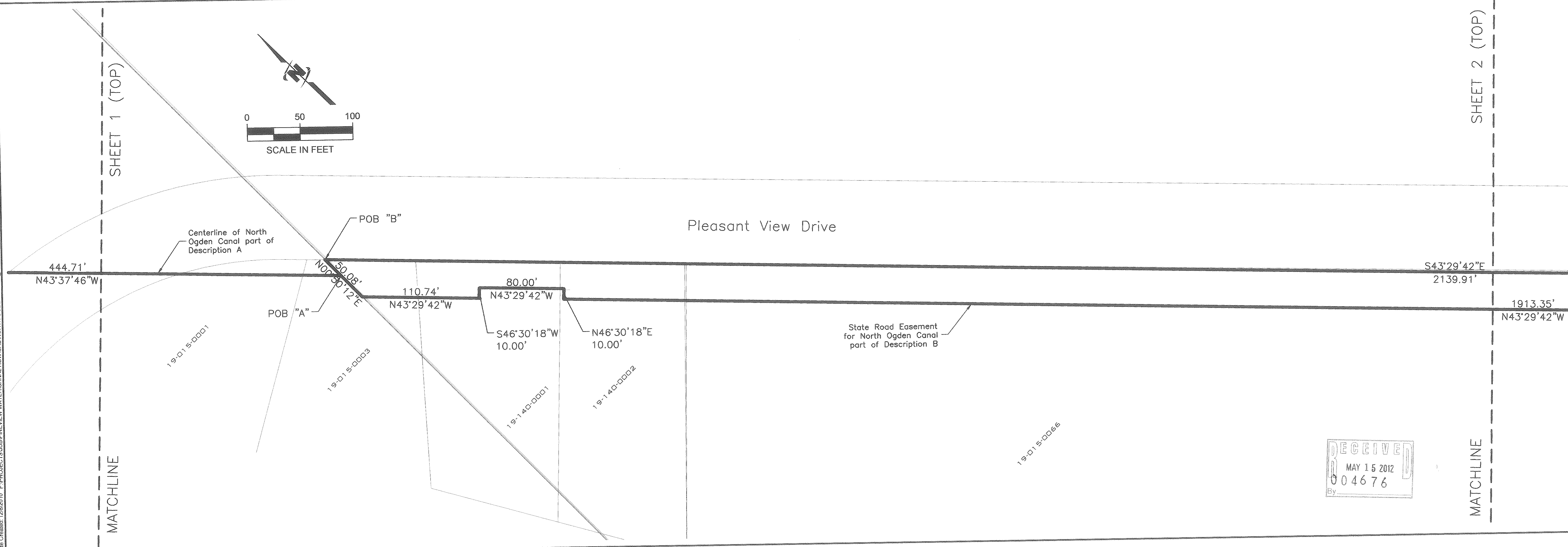
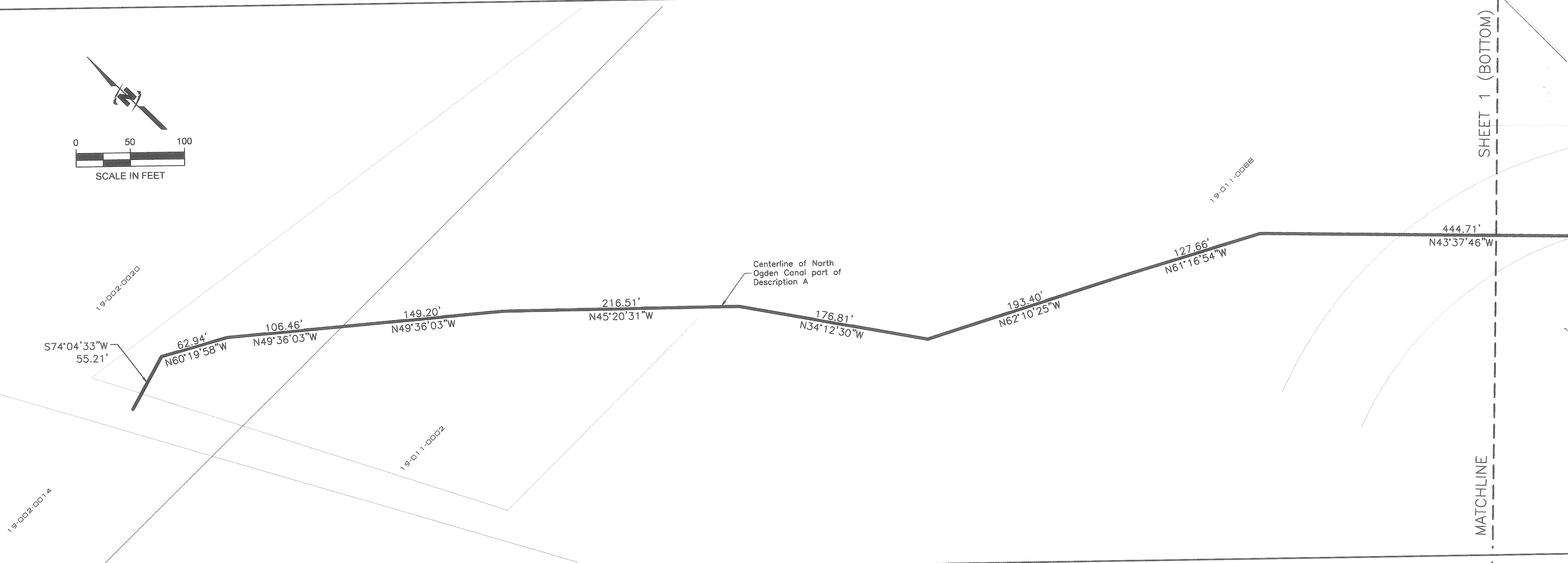
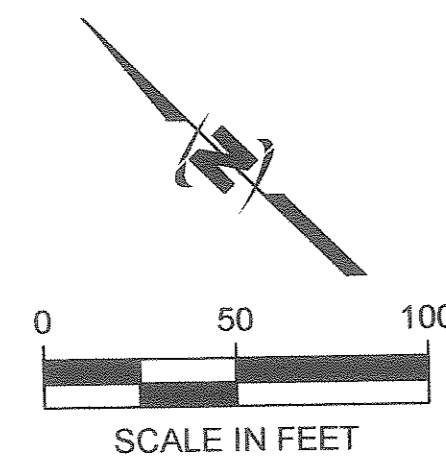
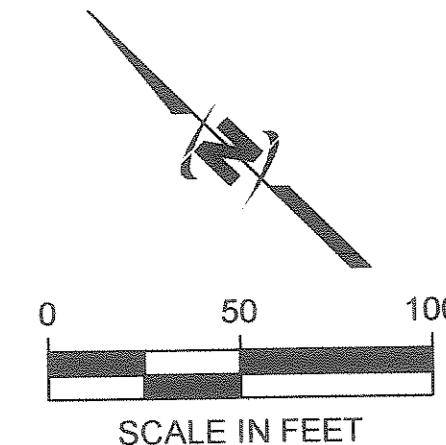

Plot Date: 5/7/2012
Data Source: 12/6/2010, F:\PROJECTS\NORTH OGDEN CANAL\NORTH OGDEN CANAL_A.DWG

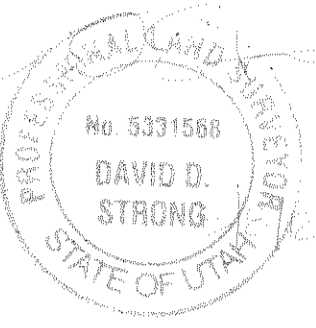

THIS DOCUMENT, AND THE IDEAS AND DESIGNS INCORPORATED HEREIN, AS AN INSTRUMENT OF PROFESSIONAL SERVICE, IS THE PROPERTY OF JUB ENGINEERS, INC. AND IS NOT TO BE USED IN WHOLE OR IN PART FOR ANY OTHER PROJECT WITHOUT THE EXPRESS WRITTEN AUTHORIZATION OF JUB ENGINEERS, INC.

NO.	REVISION	DESCRIPTION	BY	DATE

**NORTH OGDEN CANAL
 NORTH OGDEN IRRIGATION COMPANY**

RIGHT-OF-WAY PLAT

CAD FILE: NORTH OGDEN CANAL_A
 PROJ. #: PMPROJECT #5507060
 DRAWN BY: DDS/JDM
 DESIGN BY:
 CHECKED BY: DDS
 SCALE OF SHEET
 HOR SCALE: AS NOTED
 VER SCALE: AS NOTED
 LAST UPDATED: 5/11/2012

SHEET
2

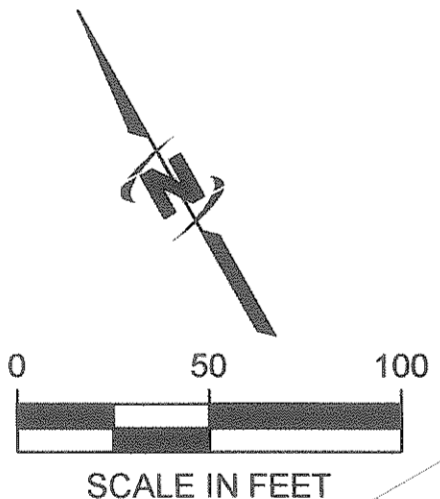
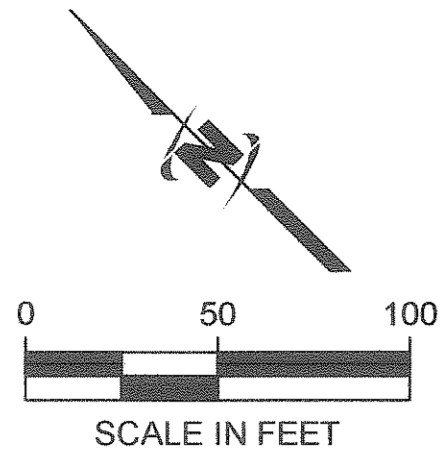
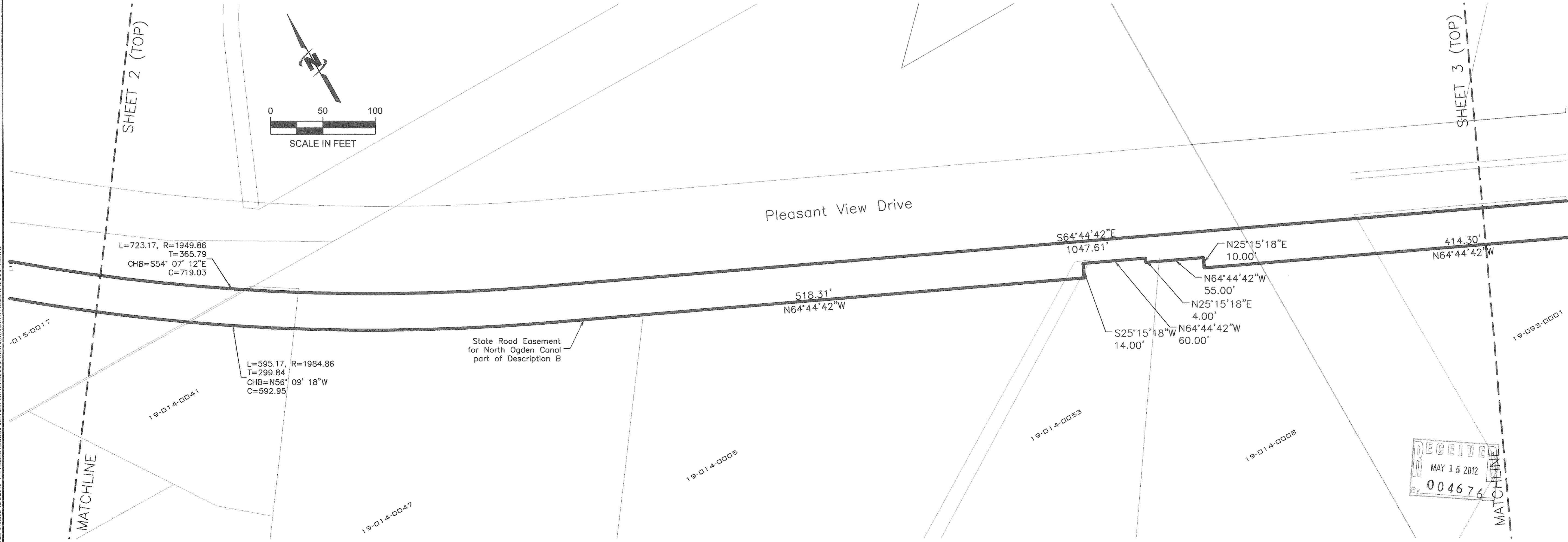
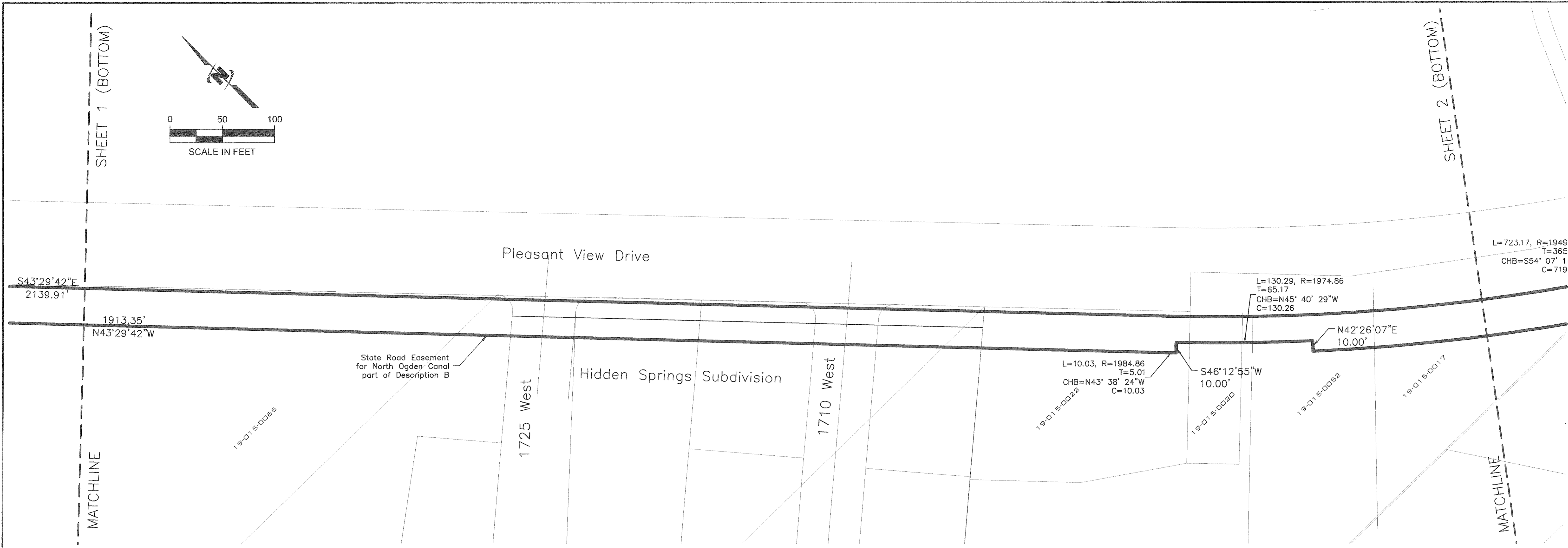

RECEIVED
 MAY 15 2012
 By 004676

Plot Date: 5/8/2012
 Date Created: 12/8/2010
 F:\PROJECTS\JUB\VIEW\WATER\CANAL\ROW\CANAL\NORTH OGDEN\CANAL_A.DWG

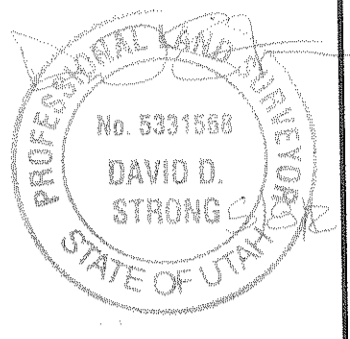

REUSE OF DRAWINGS:
THIS DOCUMENT, AND THE IDEAS AND DESIGNS INCORPORATED HEREIN, AS AN INSTRUMENT OF PROFESSIONAL SERVICE, IS THE WHOLE OR PART, FOR ANY OTHER PROJECT WITHOUT THE EXPRESS WRITTEN AUTHORIZATION OF J-U-B ENGINEERS, INC.

NO.	REVISION	DESCRIPTION	BY	DATE

**NORTH OGDEN CANAL
RIGHT-OF-WAY PLAT**

CAD FILE: NORTH OGDEN CANAL_A
PROJ. #: PMPROJECT #5507060
DRAWN BY: DDS/JDM
DESIGN BY:
CHECKED BY: DDS
SCALE OF SHEET
HOR SCALE: AS NOTED
VER SCALE: AS NOTED
LAST UPDATED: 5/7/2012

SHEET
3

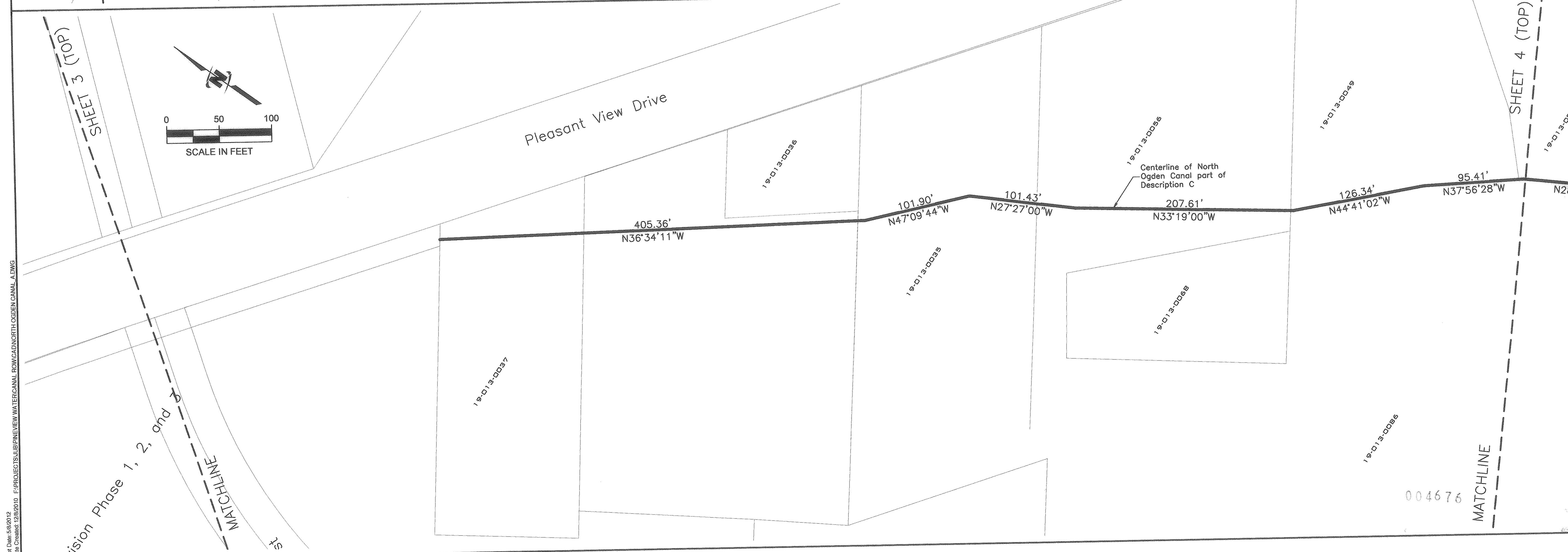
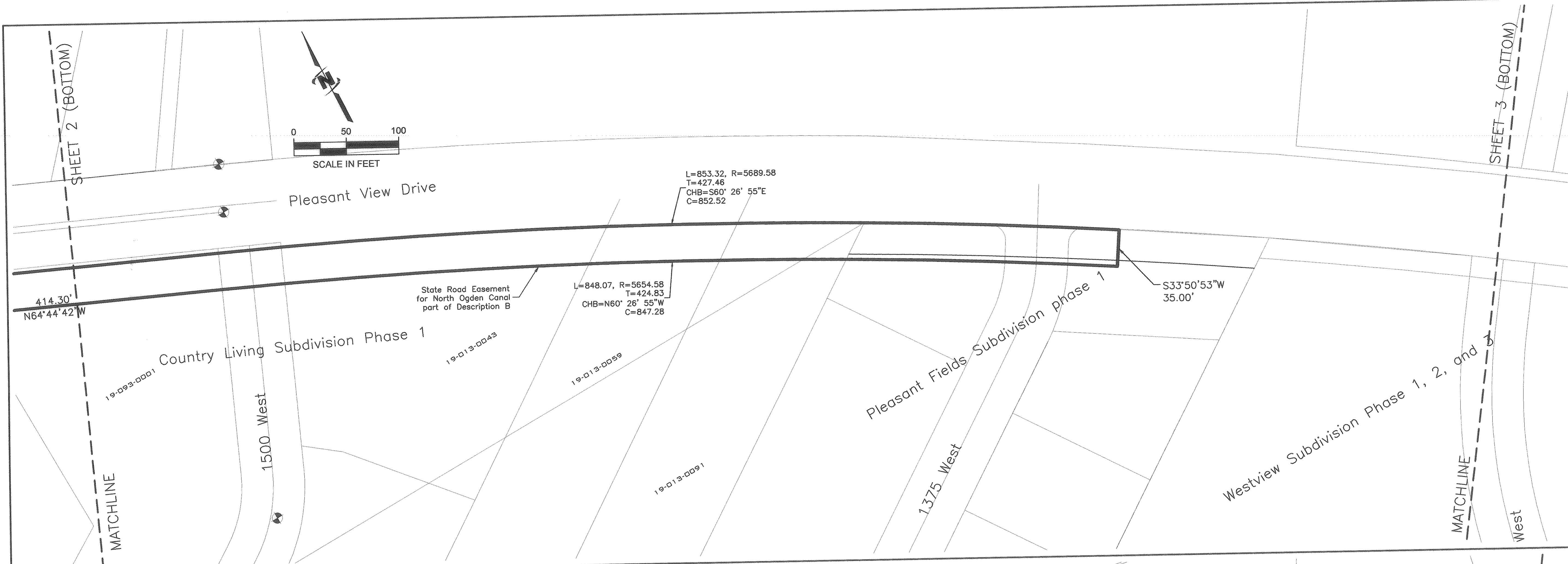

Pld Date: 5/6/2012
Date Created: 12/8/2010
F:\PROJECTS\SUBPINEVIEW WATER CANAL ROW\CAD\NORTH OGDEN CANAL_A.DWG

004676

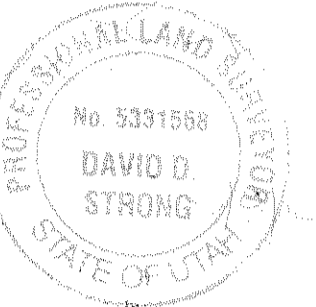

REUSE OF DRAWINGS
THIS DOCUMENT AND THE INFORMATION CONTAINED HEREIN AS AN INSTRUMENT OF PROFESSIONAL SERVICE IS THE PROPERTY OF JUB ENGINEERS, Inc. AND IS NOT TO BE USED, IN WHOLE OR PART, FOR ANY OTHER PROJECT WITHOUT THE EXPRESS WRITTEN AUTHORIZATION OF JUB ENGINEERS, Inc.

NO.	DESCRIPTION	BY	DATE

**NORTH OGDEN CANAL
NORTH OGDEN IRRIGATION COMPANY**

RIGHT-OF-WAY PLAT

CADD FILE: NORTH OGDEN CANAL A
PROJ. #: P10/PROJECT #5607080
DRAWN BY: DDSJDM
DESIGN BY:
CHECKED BY: DOS
SCALE OF SHEET:
HOR SCALE: AS NOTED
VER SCALE: AS NOTED
LAST UPDATED: 5/7/2012

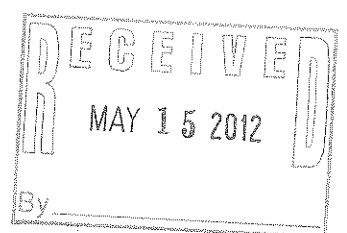
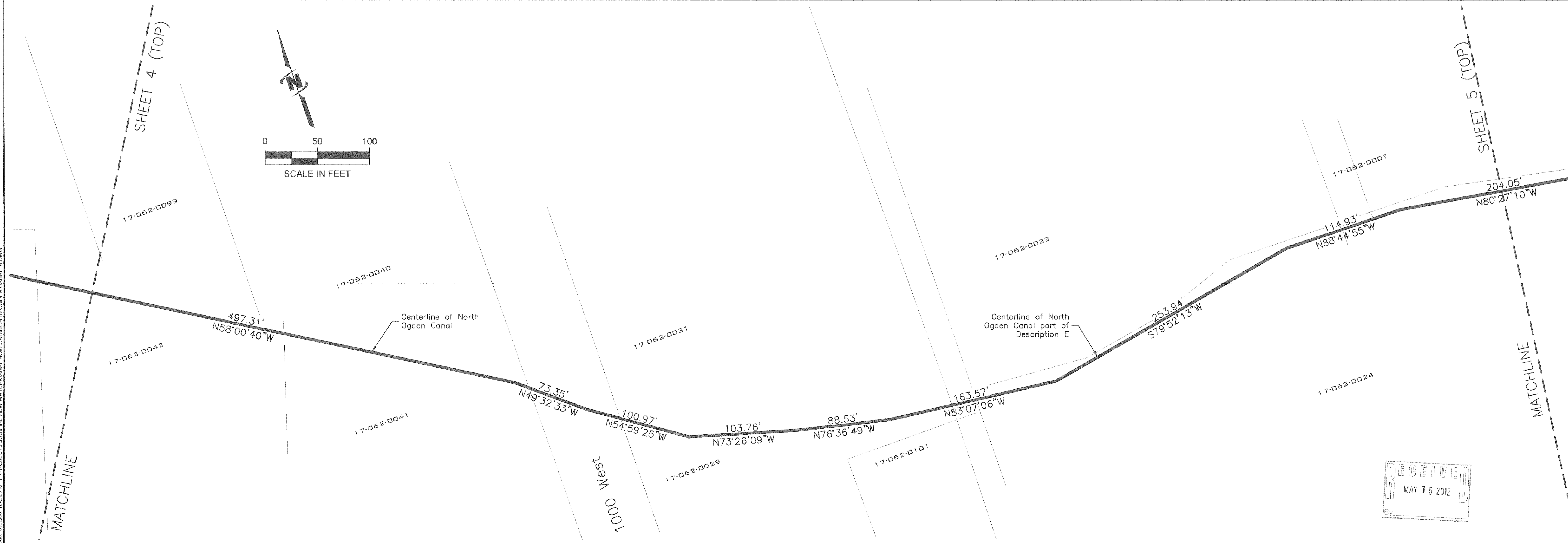
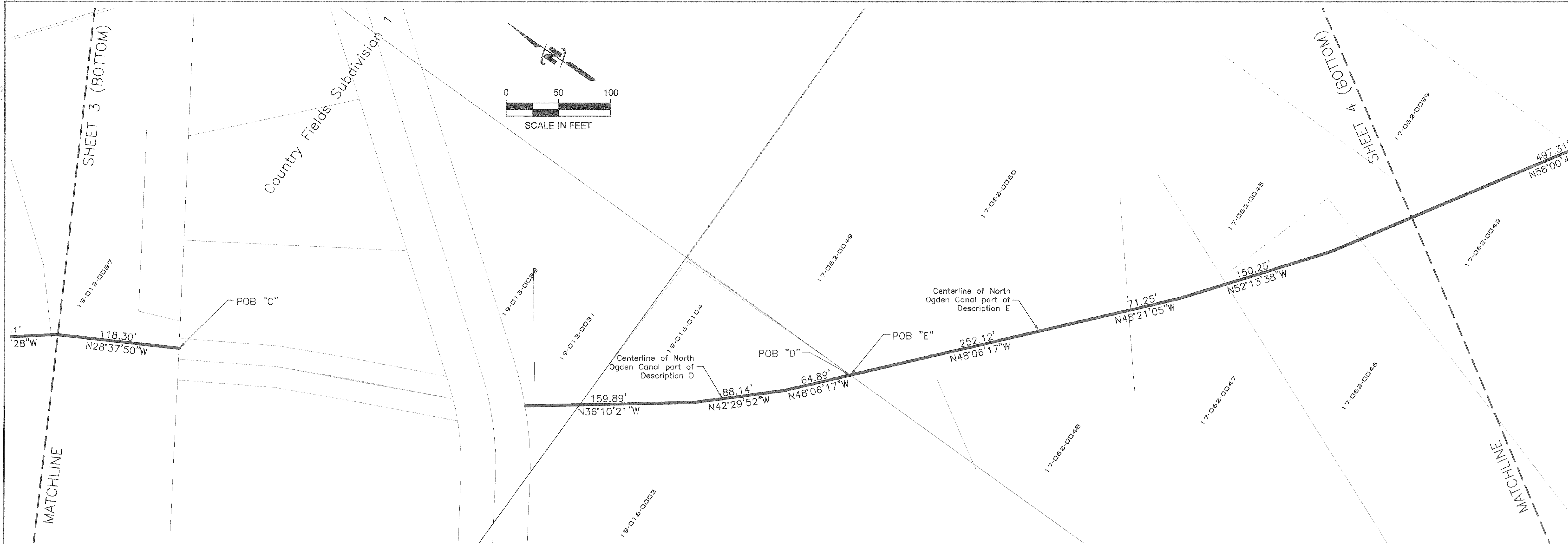

File Date: 5/8/2012
Date Created: 12/26/2010
F:\PROJECTS\SUB\VIEW\WATER\CANAL ROW\CADD\NORTH OGDEN CANAL A.DWG

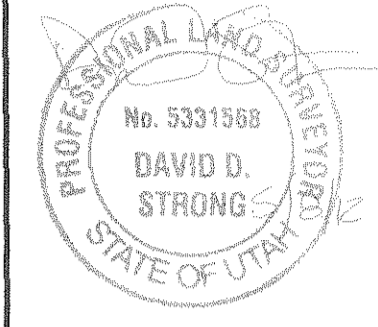

REUSE OF DRAWINGS
THIS DOCUMENT, AND THE USE OF THE INFORMATION INCORPORATED HEREIN, AS AN INSTRUMENT OF PROFESSIONAL SERVICE, IS THE PROPERTY OF J-U-B ENGINEERS, Inc. AND IS NOT TO BE USED, IN WHOLE OR PART, FOR ANY OTHER PROJECT WITHOUT THE EXPRESS WRITTEN AUTHORIZATION OF J-U-B ENGINEERS, Inc.

NO.	DESCRIPTION	BY	DATE

NORTH OGDEN CANAL
NORTH OGDEN IRRIGATION COMPANY
RIGHT-OF-WAY PLAT

CAD FILE: NORTH OGDEN CANAL_A
PROJ.#: PMP/PROJECT #5507060
DRAWN BY: DDS/JDM
DESIGN BY: DDS
CHECKED BY: DDS
SCALE OF SHEET
HOR SCALE: AS NOTED
VER SCALE: AS NOTED
LAST UPDATED: 5/7/2012
SHEET
5



Plot Date: 5/8/2012
Date Created: 12/2/2010
F:\PROJECTS\JUB\PIV\VIEW WATER CANAL\NORTH OGDEN CANAL_A.DWG

