

Narrative
 The purpose of this survey was to establish and set the property corners of the parcel as shown and described hereon. The survey was ordered by Helen Butler. The control used to establish the property corners was the existing Lakeview Heights Subdivision Phase 1 original monumentation located in the Southwest Quarter of Section 21, T7N, R1W, SLB&M. The basis of bearing is the monumented centerline of 3350 North which by record bears South 89°56'00" East.

As-Surveyed Description
 All of Lot 40, Lakeview Heights Subdivision Phase 1, Weber County, Utah.

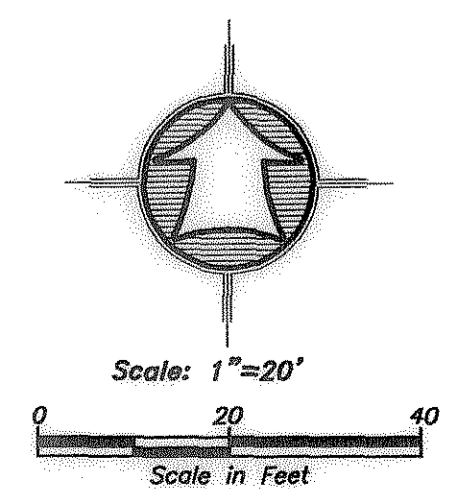

- LEGEND**
- Subject Property Line
 - - - Adjoining Property Line
 - Centerline
 - Street Monument
 - Found Survey Point
 - Set 5/8"x24" Rebar With Cap

SURVEYOR'S CERTIFICATE
 I, Clinton G. Hansen, do hereby certify that I am a Registered Professional Land Surveyor in the State of Utah in accordance with Title 58, Chapter 22, Professional Engineers and Land Surveyors Act; and by the Authority of the Owners, I have Completed a Survey of the Property Described and shown Hereon this Plat in Accordance with Section 17-23-17 and have Verified all Measurements, and that the same has been Surveyed and Monuments have been Located and/or Placed on the Ground as Represented on the plat Hereon.
 Signed this 15th day of NOVEMBER, 2012.

Clinton G. Hansen PLS
 Utah Land Surveyor Licence No. 7881387



<p>Property Survey for Helen Butler 627 East 3350 North North Ogden, Weber County, Utah A Part of the Southwest Quarter of Section 21 Township 7 North, Range 1 West, S.L.B.&M.</p>	<p>Drawn By: CGH Date: 11-15-12 Designed By: Checked By: Approved By: Scale: 1"=20' Drawing File: 12-3-170-V12.dwg JOB NUMBER: 12-3-170</p>
<p>HANSEN & ASSOCIATES, INC. Consulting Engineers and Land Surveyors 538 North Main Street, Brigham, Utah 84302 Visit us at www.hansen.net Brigham City, Ogden (435) 723-3481 (801) 399-4905 (435) 792-8272</p>	
Sheet	1
of	1
Sheets	1