

Parcel A

A Part of the Northeast Quarter of Section 20, Township 7 North, Range 1 East, of the Salt Lake Base and Meridian. Beginning at a point on the West line of said Northeast Quarter being located North 00°09'35" West 429.33 Feet along said West line from the Southwest Corner of said Northeast Quarter Said point described of record as being 903 feet South from the Northwest Corner of the Southwest Quarter of said Northeast Quarter; Running Thence South 88°52'33" East 251.00 Feet; Thence South 00°09'35" East 200.00 Feet; Thence North 88°52'33" West 251.00 Feet; Thence North 00°09'35" West 200.00 Feet to the Point of beginning. Containing 1.15 Acres.

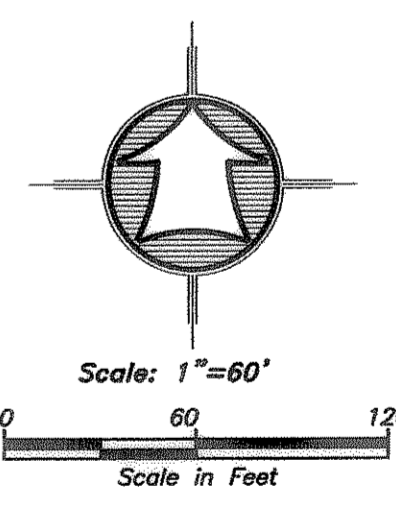

- LEGEND**
- Subject Property Line
 - - - Property Line
 - - - Adjoining Property Line
 - Centerline
 - - - Ditch
 - - - Fence Line
 - ◆ Section Corner
 - ◆ Street Monument
 - Found Survey Point
 - Set 5/8"x24" Rebar With Cap

SURVEYOR'S CERTIFICATE

I, Clinton G. Hansen, do hereby certify that I am a Registered Professional Land Surveyor in the State of Utah in accordance with Title 58, Chapter 22, Professional Engineers and Land Surveyors Act; and by the Authority of the Owners, I have Completed a Survey of the Property Described and shown Hereon this Plat in Accordance with Section 17-23-17 and have Verified all Measurements, and that the same has been Surveyed and Monuments have been Located and/or Placed on the Ground as Represented on the plat Hereon.

Signed this 1st day of FEBRUARY, 2013.

Clinton G. Hansen PLS
Utah Land Surveyor License No. 7881387

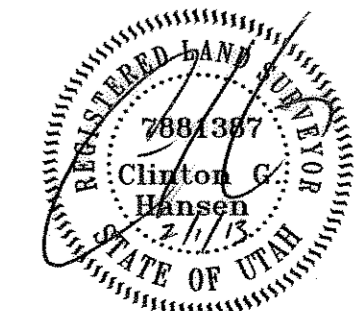

Narrative

The purpose of this survey was to establish and set the property corners of the parcel as shown and described hereon. The survey was ordered by Brian Barnett. The control used to establish the property corners was the existing Weber County Survey Monumentation surrounding Section 20, T7N, R1E, S.L.B.&M. The Plated South Line of Pettigrew Subdivision was held as the North Line of the Subject Property which coincides with physical occupation. The basis of bearing is the West line of the Northeast Quarter of said Section which bears North 00°09'35" West, Utah North, State Plane, Calculated N.A.D.83 Bearing.

Drawn By: klw Date: 1-21-13
 Design d By: _____
 Checked By: _____
 Approved By: _____
 Scale: 1"=60'
 Drawing File: 13-3-6 v12.dwg
 JOB NUMBER: 13-3-6

Property Survey for
Brian Barnett
 3962 North 3500 East
 Eden, Weber County, Utah
 A Part of the Northeast Quarter of Section 20,
 Township 7 North, Range 1 East, S.L.B.&M.

Sheet
1
 of
1
 Sheets

No.	Date	By	Revision

HANSEN & ASSOCIATES, INC.
 Consulting Engineers and Land Surveyors
 538 North Main Street, Brigham, Utah 84302
 Visit us at www.hales.net
 Ogden
 Logan
 (801) 999-4491 (801) 752-4272
 (435) 723-3491 (435) 752-4272

