

Bitton Subdivision
 Weber County, Utah
 A Part of the Northwest Quarter of Section 26,
 Township 6 North, Range 3 West, Salt Lake Base & Meridian
 December 2013

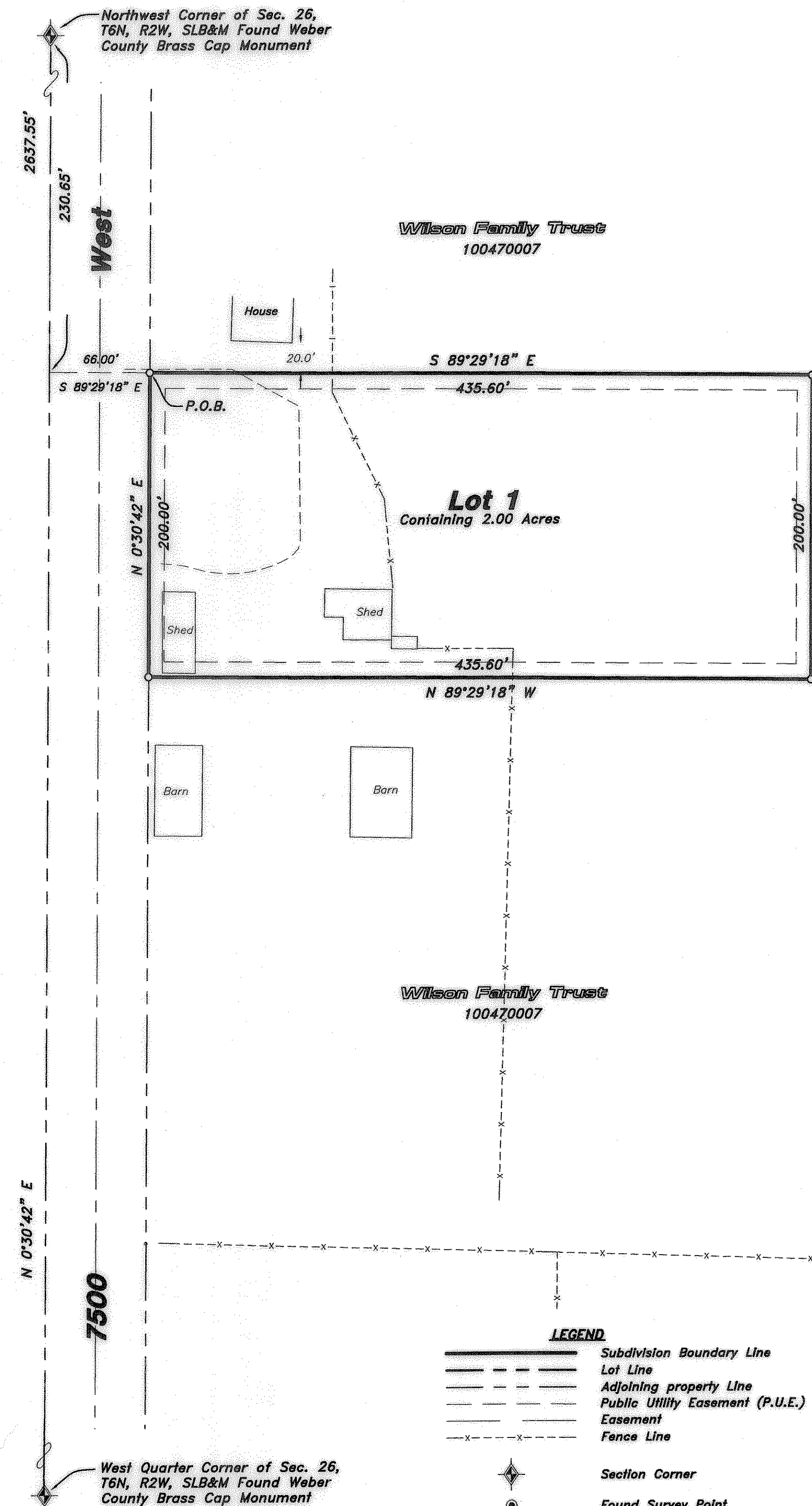

SURVEYOR'S CERTIFICATE

I, K. Greg Hansen, do hereby certify that I am a Registered Professional Land Surveyor in the State of Utah in accordance with Title 58, Chapter 22, Professional Engineers and Land Surveyors Act; and I have completed a Survey of the Property Described on this Plat in accordance with Section 17-23-17 and have Verified all Measurements, and have Placed Monuments as Represented on this Plat, and have Hereby Subdivided said Tract into One (1) Lot, know Hereafter as Bitton Subdivision in Weber County, Utah, and has been Correctly Drawn to the Designated Scale and is True and Correct Representation of the Herein Described Lands Included in said Subdivision, Based Upon Data Compiled from Records in the Weber County Recorder's Office and from said Survey made by me on the Ground, I Further Hereby Certify that the Requirements of all Applicable Statutes and Ordinances of Weber County Concerning Zoning Requirements Regarding Lot Measurements have been Complied with.

Signed this 22ND day of May, 2013.

K. Greg Hansen P.L.S.
 Utah Land Surveyor Licence No. 167819

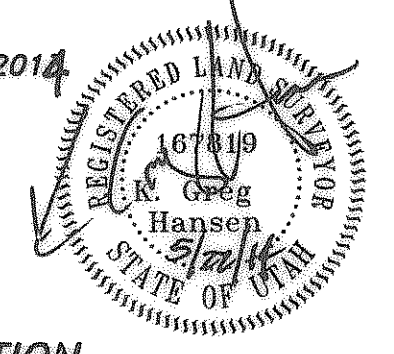

BOUNDARY DESCRIPTION

A PART OF THE NORTHWEST QUARTER OF SECTION 26, TOWNSHIP 6 NORTH, RANGE 3 WEST OF THE SALT LAKE BASE AND MERIDIAN.

BEGINNING AT A POINT ON THE EAST RIGHT-OF-WAY LINE OF 7500 WEST STREET LOCATED 230.65 FEET SOUTH 00°30'42" WEST ALONG THE WEST LINE OF SAID NORTHWEST QUARTER AND 66.00 FEET SOUTH 89°29'18" EAST FROM THE NORTHWEST CORNER OF SAID SECTION 26; RUNNING THENCE SOUTH 89°29'18" EAST 435.60 FEET; THENCE SOUTH 00°30'42" WEST 200.00 FEET; THENCE NORTH 89°29'18" WEST 435.60 FEET TO SAID EAST RIGHT-OF-WAY LINE; THENCE NORTH 00°30'42" EAST 200.00 FEET ALONG SAID EAST RIGHT-OF-WAY LINE TO THE POINT OF BEGINNING. CONTAINING 2.000 ACRES.

NARRATIVE

The Purpose of this Survey was to Establish and set the Property Corners of the One Lot Subdivision as Shown and described hereon. The survey was ordered by Jennifer Bitton. The Control used to Establish the Property Corners was the Existing Weber County Surveyor Monumentation Surrounding Section 26, Township 6 North, Range 3 West, S.L.B.&M. The basis of bearing is the West line of the Northwest Quarter of said Section which bears South 0°30'42" East, Utah North, State Plane, Calculated N.A.D.83 Bearing.

OWNER'S DEDICATION AND CERTIFICATION

Know all men by these presents that we, the undersigned Owners of the above described tract of land having caused the same to be subdivided into a lot and streets, as shown on this plat and name said tract Bitton Subdivision and hereby dedicate, grant and convey, in perpetuity, pursuant to the provisions of 10-9a-607, Utah code, without condition, restriction or reservation to Weber County, Utah, all those parts or portions of said tract of land designated as streets the same to be used as public thoroughfares forever, and also dedicate to Weber County those certain strips as easements for public utility and drainage purposes as shown hereon. The same to be used for the installation, maintenance and operation of public utility service lines and drainage as may be authorized by the Governing Authority in witness we have here unto set our signature this 22ND day of May, 2013.

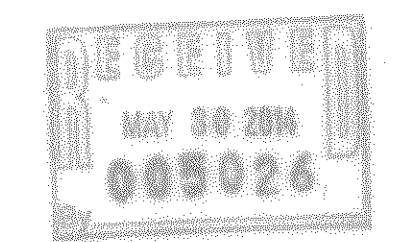

Donald L. Willson Trustee for the Willson Family Trust
 Joanne West Willson Trustee for the Willson Family Trust

TRUST ACKNOWLEDGMENT

State of Utah
 County of _____
 On this 22ND day of May, 2013.
 Trustee for the Willson Family trust, personally appeared before me, the undersigned notary public in and for said county, in the state of Utah, the signers of the attached owners dedication, two in numbers, who duly acknowledged to me they signed it freely and voluntarily and for the purpose therein mentioned on behalf of said trust.

Notary public

WEBER COUNTY ENGINEER

I hereby certify that the Required Public Improvement Standards and Drawings for this Subdivision Conform with the County Standards and the Amount of the Financial Guarantee is Sufficient for the Installation of these Improvements.
 Signed this _____ Day of _____, 2013.

 Weber County Engineer

WEBER COUNTY PLANNING COMMISSION APPROVAL

This is to Certify that this Subdivision Plat was Duly Approved by the Weber County Planning Commission.
 Signed this _____ Day of _____, 2013.

 Chairman, Weber County Planning Commission

AGRICULTURAL NOTE

Agriculture is the preferred use in the Agriculture Zones. Agriculture operations as specified in the zoning ordinance for a particular zone are permitted at any time including the operation of farm machinery and no allowed agriculture use shall be subject to restriction on that it interferes with activities of future residents of this subdivision

WEBER COUNTY COMMISSION ACCEPTANCE

This is to Certify that this Subdivision Plat, the Dedication of Streets and other Public Ways and Financial Guarantee of Public Improvements Associated with this Subdivision, Thereon are Hereby Approved and Accepted by the Commissioners of Weber County Utah
 Signed this _____ Day of _____, 2013.

 Chairman, Weber County Commission

WEBER COUNTY SURVEYOR

I hereby certify that the Weber County Surveyor's Office has Reviewed this Plat for Mathematical Correctness, Section Corner Data, and for Harmony with the Lines and Monuments on Record in County Offices. The Approval of this Plat by the Weber County Surveyor does not Relieve the Licensed Land Surveyor who Executed this Plat from the Responsibilities and/or Liabilities Associated Therewith. Signed this _____ Day of _____, 2013.

 Weber County Surveyor

WEBER COUNTY ATTORNEY

I have Examined the Financial Guarantee and Other Documents Associated with this Subdivision Plat, and in my Opinion they Conform with the County Ordinance Applicable Thereto and now in Force and Affect
 Signed this _____ Day of _____, 2013.

 Weber County Attorney

WEBER-MORGAN HEALTH DEPARTMENT

I hereby Certify that the Soils, Percolation Rates, and Site Conditions for this Subdivision have been Investigated by this Office and are Approved for On-Site Wastewater Disposal Systems.
 Signed this _____ Day of _____, 2013.

 Weber-Morgan Health Department

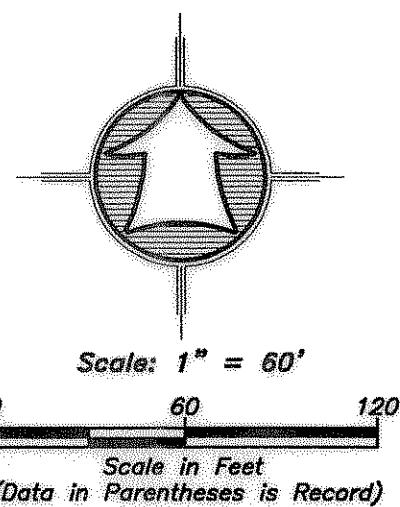

Notes:
 1- ALL PUBLIC UTILITY EASEMENTS (P.U.E.) ARE 10.00 FEET WIDE UNLESS NOTED OTHERWISE.

HANSEN & ASSOCIATES, INC.
 Consulting Engineers and Land Surveyors
 538 North Main Street, Brigham, Utah 84302
 Visit us at www.haies.net
 Brigham City Ogdan Logan
 (435) 723-3491 (801) 399-4905 (435) 752-8272