

# EDGEWATER BEACH RESORT PHASE 1 - 1ST AMENDMENT

## A PLANNED RESIDENTIAL UNIT DEVELOPMENT (P.R.U.D.)

PART OF THE SOUTHWEST QUARTER OF SECTION 13, TOWNSHIP 6 NORTH, RANGE 1 EAST, SALT LAKE BASE AND MERIDIAN, U.S. SURVEY  
WEBER COUNTY, UTAH  
AUGUST, 2012

### SECTION TIES

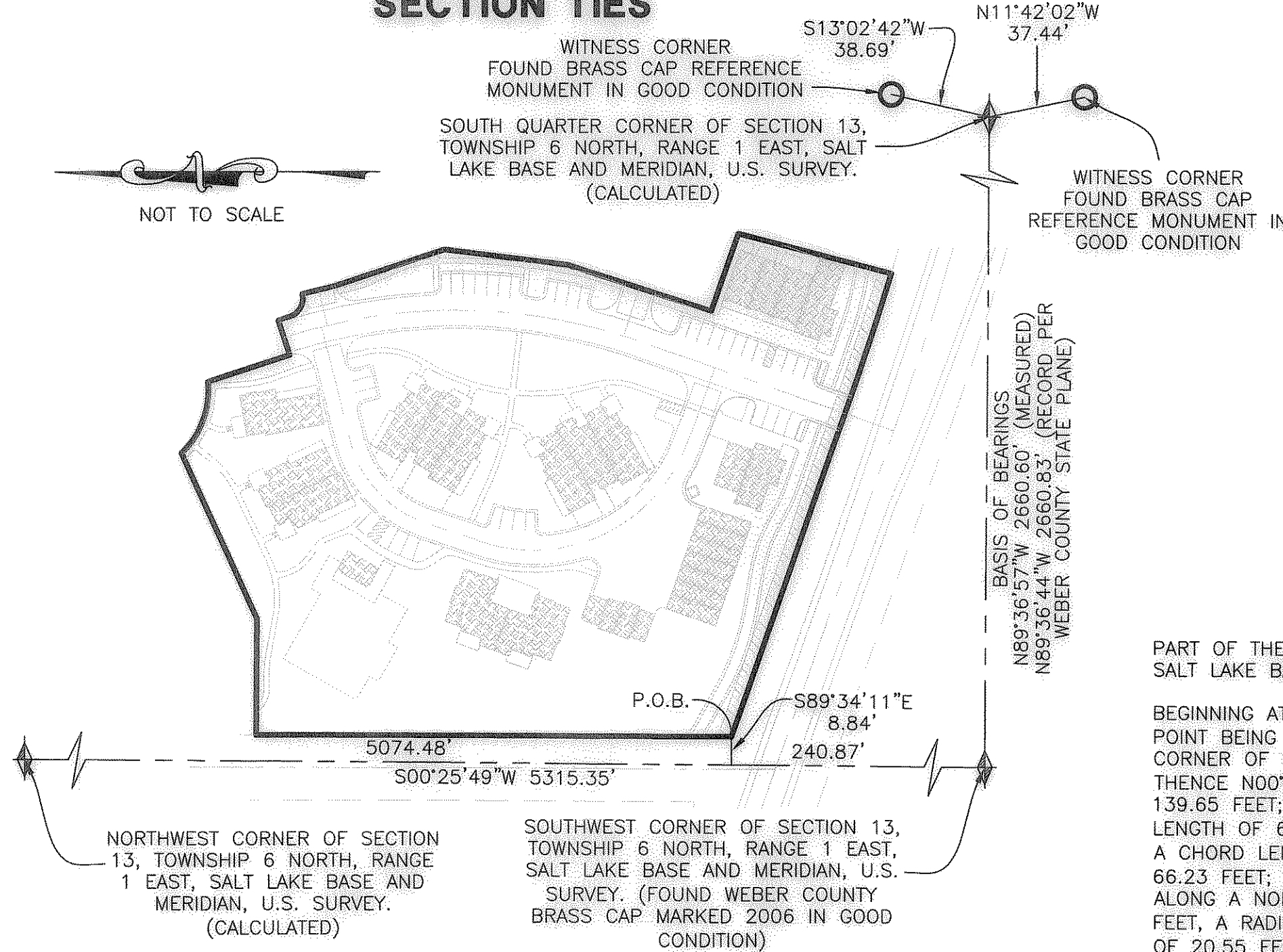

### LAND USE

TOTAL AREA.....	161,664 S.F. (3.711 ACRES)
COMMON AREA.....	122,980 S.F. (2.823 ACRES) 76%
ROAD AREA.....	30,140 S.F. (0.692 ACRES)
OPEN AREA.....	92,840 S.F. (2.131 ACRES)
LIMITED COMMON AREA.....	6,486 S.F. (0.149 ACRES) 4%
BUILDING AREA.....	32,198 S.F. (0.739 ACRES) 20%

**PROJECT BENCHMARK**  
MONUMENT NO. 3-JRH  
ELEVATION=4969.025'  
(MAINTAINED BY WEBER COUNTY SURVEYOR)

**DEVELOPER**  
CELTIC BANK  
268 S. STATE STREET  
SALT LAKE CITY, UT 84111  
801-363-6500 - DIRECT  
801-363-6562 ~ FAX

### BASIS OF BEARINGS

THE BASIS OF BEARINGS FOR THIS PLAT IS THE SECTION LINE BETWEEN THE SOUTH QUARTER CORNER AND THE SOUTHWEST CORNER OF SECTION 13, TOWNSHIP 6 NORTH, RANGE 1 EAST, SALT LAKE BASE AND MERIDIAN, U.S. SURVEY. SHOWN HEREON AS: N89°36'57\"/>

### NARRATIVE

THE PURPOSE OF THIS PLAT IS TO DIVIDE THE BELOW DESCRIBED PROPERTY INTO A SUBDIVISION PLAT. ALL BOUNDARY CORNERS WERE SET WITH A 5/8" X 24" REBAR AND PLASTIC CAP STAMPED "REEVE & ASSOCIATES".

### SURVEYOR'S CERTIFICATE

I, **ROBERT D. KUNZ**, DO HEREBY CERTIFY THAT I AM A REGISTERED PROFESSIONAL LAND SURVEYOR IN THE STATE OF UTAH IN ACCORDANCE WITH TITLE 58, CHAPTER 22, PROFESSIONAL ENGINEERS AND LAND SURVEYORS ACT; AND THAT I HAVE COMPLETED A SURVEY OF THE PROPERTY DESCRIBED ON THIS PLAT IN ACCORDANCE WITH SECTION 17-23-17 AND HAVE VERIFIED ALL MEASUREMENTS, AND HAVE PLACED MONUMENTS AS REPRESENTED ON THIS PLAT, AND THAT THIS PLAT OF **EDGEWATER BEACH RESORT PHASE 1 - 1ST AMENDMENT** IN WEBER COUNTY, UTAH, HAS BEEN DRAWN CORRECTLY TO THE DESIGNATED SCALE AND IS A TRUE AND CORRECT REPRESENTATION OF THE HEREIN DESCRIBED LANDS INCLUDED IN SAID SUBDIVISION, BASED UPON DATA COMPILED FROM RECORDS IN THE **WEBER COUNTY** RECORDER'S OFFICE AND FROM SAID SURVEY MADE BY ME ON THE GROUND, I FURTHER CERTIFY THAT THE REQUIREMENTS OF ALL APPLICABLE STATUTES AND ORDINANCES OF **WEBER COUNTY** CONCERNING ZONING REQUIREMENTS REGARDING LOT MEASUREMENTS HAVE BEEN COMPLIED WITH.

SIGNED THIS 30<sup>th</sup> DAY OF September, 2014.

150228  
UTAH LICENSE NUMBER

*Robert D. Kunz*  
ROBERT D. KUNZ

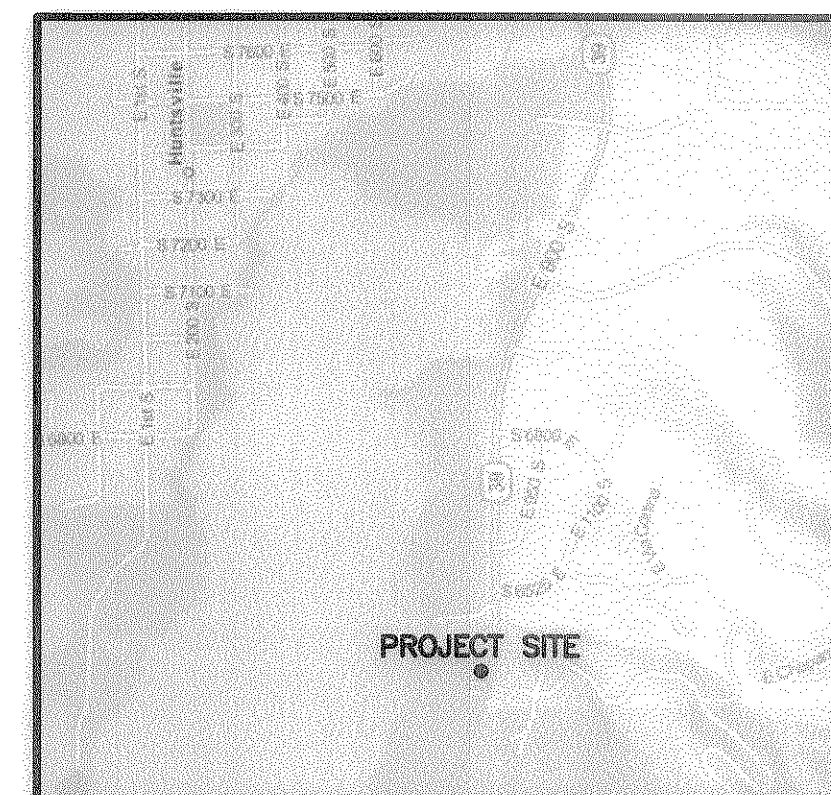
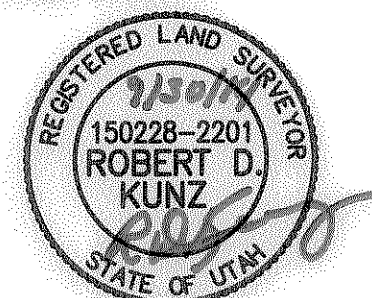

VICINITY MAP  
NO SCALE

### BOUNDARY DESCRIPTION

PART OF THE SOUTHWEST QUARTER OF SECTION 13, TOWNSHIP 6 NORTH, RANGE 1 EAST, SALT LAKE BASE AND MERIDIAN, U.S. SURVEY, DESCRIBED AS FOLLOWS:

BEGINNING AT A POINT ON THE NORTH RIGHT OF WAY LINE OF STATE HIGHWAY 39, SAID POINT BEING N00°25'49"E 240.87 FEET AND S89°34'11"E 8.84 FEET FROM THE SOUTHWEST CORNER OF SECTION 13;  
THENCE N00°09'59"E 361.28 FEET; THENCE S89°34'11"E 103.01; THENCE N65°29'31"E 139.65 FEET; THENCE ALONG A NON-TANGENT CURVE TURNING TO THE LEFT WITH AN ARC LENGTH OF 60.50 FEET, A RADIUS OF 66.72 FEET, A CHORD BEARING OF S69°52'48"E AND A CHORD LENGTH OF 58.45 FEET WITH A DELTA ANGLE OF 51°57'15"; THENCE S17°58'09"E 66.23 FEET; THENCE N72°01'51"E 28.00 FEET; THENCE S17°38'34"E 8.59 FEET; THENCE ALONG A NON-TANGENT CURVE TURNING TO THE LEFT WITH AN ARC LENGTH OF 22.64 FEET, A RADIUS OF 15.00 FEET, A CHORD BEARING OF S60°20'46"E, AND A CHORD LENGTH OF 20.55 FEET WITH A DELTA ANGLE OF 86°27'51"; THENCE S13°34'41"E 26.00 FEET; THENCE S18°32'05"E 88.52 FEET; THENCE S06°58'25"W 95.65 FEET; THENCE S17°56'43"W 115.86 FEET; THENCE S70°43'57"E 63.32 FEET; THENCE S14°34'00"W 121.64 FEET TO THE NORTH RIGHT OF WAY LINE OF STATE HIGHWAY 39; THENCE ALONG SAID NORTH RIGHT OF WAY LINE THE FOLLOWING TWO (2) COURSES: (1) ALONG A NON-TANGENT CURVE TURNING TO THE RIGHT WITH AN ARC LENGTH OF 81.69 FEET, A RADIUS OF 1869.86 FEET, A CHORD BEARING OF N71°58'42"W, AND A CHORD LENGTH OF 81.68 FEET WITH A DELTA ANGLE OF 02°30'11"; AND (2) N70°43'36"W 309.30 FEET TO THE POINT OF BEGINNING.

CONTAINING 163,110 SQUARE FEET AND 3.744 ACRES

### NOTES

- ALL DRIVEWAYS, PATIOS, DECKS, BALCONIES, ON UNIT 101 THROUGH 104 CONTAINED WITHIN THE PROJECT ARE DEDICATED LIMITED COMMON AREAS. ALL DRIVEWAYS TO PADS ARE DEDICATED LIMITED COMMON AREAS. THEY ARE SET ASIDE AND RESERVED FOR THE USE OF THE RESPECTIVE CONDOMINIUM UNIT OR PAD TO WHICH THEY ARE ATTACHED OR APPURTENANT.
- ALL OTHER AREAS CONTAINED WITHIN THE PROJECT, BUT NOT SHOWN WITH DIAGONAL STRIPE OR CROSS HATCHED LINES ARE DEDICATED AS COMMON AREA, INCLUDING COVERED AND UNCOVERED PARKING, PRIVATE STREETS, PUBLIC UTILITY, STORM WATER DETENTION AND DRAINAGE EASEMENT AREA. COMMON AREAS ARE TO BE USED FOR RECREATIONAL AND OPEN SPACE PURPOSES FOR THE BENEFIT OF EACH EDGEWATER BEACH RESORT PHASE 1 HOA, INC. MEMBER IN COMMON WITH ALL OTHERS IN THE CONDOMINIUM AND GRANT AND DEDICATE TO THE GOVERNING AUTHORITY A PERPETUAL OPEN SPACE RIGHT AND EASEMENT ON AND OVER THE COMMON AREA TO GUARANTEE THAT THE COMMON AREAS REMAIN OPEN AND UNDEVELOPED EXCEPT FOR APPROVED RECREATIONAL, PARKING AND OPEN SPACE PURPOSES.
- DIMENSIONS ON SHEET 2 OF 4 ARE TO EXTERIOR FOUNDATION ONLY.
- EIGHT INCH CULINARY WATERLINE AND THE SANITARY SEWER MAIN TO BE OWNED AND MAINTAINED BY LAKEVIEW WATER SYSTEM AND MOUNTAIN SEWER CORPORATION RESPECTIVELY.
- THERE ARE NO CONVERTIBLE OR WITHDRAWALABLE AREAS IN THIS PROJECT PHASE.
- ALL BUILDING TIE DIMENSIONS ARE PERPENDICULAR TO BOUNDARY LINE OR ROAD CENTERLINE.
- UNITS 101-104 ARE TO BE DEDICATED AS CONDOMINIUM UNITS.

### ACKNOWLEDGMENT

STATE OF UTAH ) ss.  
COUNTY OF \_\_\_\_\_ )  
ON THE \_\_\_\_\_ DAY OF \_\_\_\_\_, 20\_\_\_\_, PERSONALLY APPEARED BEFORE ME, THE UNDERSIGNED NOTARY PUBLIC, SIGNER(S) OF THE ABOVE OWNER'S DEDICATION AND CERTIFICATION, WHO BEING BY ME DULY SWORN, DID ACKNOWLEDGE TO ME \_\_\_\_\_ SIGNED IT FREELY, VOLUNTARILY, AND FOR THE PURPOSES THEREIN MENTIONED.

COMMISSION EXPIRES \_\_\_\_\_ NOTARY PUBLIC

### ACKNOWLEDGMENT

STATE OF UTAH ) ss.  
COUNTY OF \_\_\_\_\_ )  
ON THE \_\_\_\_\_ DAY OF \_\_\_\_\_, 20\_\_\_\_, PERSONALLY APPEARED BEFORE ME, THE UNDERSIGNED NOTARY PUBLIC, SIGNER(S) OF THE ABOVE OWNER'S DEDICATION AND CERTIFICATION, WHO BEING BY ME DULY SWORN, DID ACKNOWLEDGE TO ME \_\_\_\_\_ SIGNED IT FREELY, VOLUNTARILY, AND FOR THE PURPOSES THEREIN MENTIONED.

COMMISSION EXPIRES \_\_\_\_\_ NOTARY PUBLIC

### OWNERS DEDICATION AND CONSENT TO RECORD

KNOW ALL MEN BY THESE PRESENTS: CELTIC BANK, WHICH IS THE OWNER OF THE TRACT OF LAND DESCRIBED HEREON AND EDGEWATER BEACH RESORT PHASE 1 - 1ST AMENDMENT, A PLANNED RESIDENTIAL UNIT DEVELOPMENT (PRUD) LOCATED ON SAID TRACT OF LAND, DO HEREBY MAKE THIS CERTIFICATE FOR AND ON BEHALF OF SAID CORPORATION AND HAVE CAUSED; 1. A SURVEY TO BE MADE AND 2. THIS PLANNED RESIDENTIAL UNIT DEVELOPMENT PLAT, CONSISTING OF (4) SHEETS. SAID CELTIC BANK DOES HEREBY CONSENT TO RECORD THIS PLANNED RESIDENTIAL UNIT DEVELOPMENT PLAT IN ACCORDANCE WITH THE UTAH CONDOMINIUM OWNERSHIP ACT; WE THE UNDERSIGNED OWNERS OF THE HEREIN DESCRIBED TRACT OF LAND, DO HEREBY SET APART AND SUBDIVIDE THE SAME INTO UNITS AND PADS AND PUBLIC AND PRIVATE STREETS AS SHOWN HEREON AND NAME SAID TRACT EDGEWATER BEACH RESORT PHASE 1 - 1ST AMENDMENT, AND DO HEREBY:

DEDICATE TO PUBLIC USE ALL THOSE PARTS OR PORTIONS OF SAID TRACT OF LAND DESIGNATED AS PUBLIC STREETS, THE SAME TO BE USED AS PUBLIC THOROUGHFARES. DEDICATE AND RESERVE UNTO THEMSELVES, THEIR HEIRS, THEIR GRANTEEES AND ASSIGNS, A RIGHT-OF-WAY TO BE USED IN COMMON WITH ALL OTHERS WITHIN SAID SUBDIVISION (AND THOSE ADJOINING SUBDIVISIONS THAT MAY BE SUBDIVIDED BY THE UNDERSIGNED OWNERS, THEIR SUCCESSORS, OR ASSIGNS) ON, OVER AND ACROSS ALL THOSE PORTIONS OR PARTS OF SAID TRACT OF LAND DESIGNATED ON SAID PLAT AS PRIVATE STREETS AS ACCESS TO THE INDIVIDUAL UNITS AND PADS, TO BE MAINTAINED BY A UNIT AND PAD OWNERS ASSOCIATION WHOSE MEMBERSHIP CONSISTS OF SAID OWNERS, THEIR GRANTEEES, SUCCESSORS, OR ASSIGNS. GRANT AND CONVEY TO EDGEWATER BEACH RESORT PHASE 1 HOA, INC., ALL THOSE PARTS OR PORTIONS OF SAID TRACT OF LAND DESIGNATED AS COMMON AREAS TO BE USED FOR RECREATIONAL AND OPEN SPACE PURPOSES FOR THE BENEFIT OF EACH EDGEWATER BEACH RESORT PHASE 1 HOA, INC. MEMBER IN COMMON WITH ALL OTHERS IN THE SUBDIVISION AND GRANT AND DEDICATE TO WEBER COUNTY A PERPETUAL EASEMENT ON AND OVER THE COMMON AREAS TO GUARANTEE TO WEBER COUNTY THAT THE COMMON AREAS REMAIN OPEN AND UNDEVELOPED EXCEPT FOR APPROVED RECREATIONAL, PARKING AND OPEN SPACE PURPOSES. GRANT AND DEDICATE A PERPETUAL RIGHT AND EASEMENT OVER, UPON AND UNDER THE LANDS DESIGNATED HEREOF AS PUBLIC UTILITY, STORM WATER DETENTION PONDS DRAINAGE EASEMENTS AND CANAL MAINTENANCE EASEMENT, THE SAME TO BE USED FOR THE INSTALLATION MAINTENANCE AND OPERATION OF PUBLIC UTILITY SERVICE LINE, STORM DRAINAGE FACILITIES, IRRIGATION CANALS OR FOR THE PERPETUAL PRESERVATION OF WATER CHANNELS IN THEIR NATURAL STATE WHICHEVER IS APPLICABLE AS MAY BE AUTHORIZED BY THE GOVERNING AUTHORITY, WITH NO BUILDINGS OR STRUCTURES BEING ERECTED WITHIN SUCH EASEMENTS. GRANT AND DEDICATE UNTO ALL OWNERS OF UNITS AND PADS UPON WHICH PRIVATE LAND DRAINS ARE CONSTRUCTED OR WHICH ARE OTHERWISE DEPENDENT UPON SUCH LAND DRAINS, AN EASEMENT OVER SUCH LAND DRAINS FOR THE PURPOSE OF PERPETUAL MAINTENANCE AND OPERATION. DEDICATE, GRANT AND CONVEY TO THE GOVERNING AUTHORITY, OR ITS DESIGNEE, ALL THOSE PARTS OR PORTIONS OF SAID TRACT OF LAND DESIGNATED AS PARKS THE SAME TO BE USED AS PUBLIC OPEN SPACE. ALL COMMON AREA, INCLUDING THE PRIVATE STREETS, IS CONSIDERED TO BE AN EASEMENT FOR PUBLIC UTILITY AND DRAINAGE PURPOSES. NOTES NUMBER 1, 2, & 7 ARE BY REFERENCE MADE A PART HEREOF AND INCORPORATED HEREIN.

SIGNED THIS \_\_\_\_\_ DAY OF \_\_\_\_\_, 20\_\_\_\_.

JEFFREY W. SHUGARS AND KRISTINA SHUGARS, AS JOINT TENANTS

JAMES T. ROBERTS AND KATHERINE B. ROBERTS, AS JOINT TENANTS

CELTIC BANK CORPORATION DAVID LEE TOWERS, A MARRIED MAN

### ACKNOWLEDGMENT

STATE OF UTAH ) ss.  
COUNTY OF \_\_\_\_\_ )  
ON THE \_\_\_\_\_ DAY OF \_\_\_\_\_, 20\_\_\_\_, PERSONALLY APPEARED BEFORE ME, THE UNDERSIGNED NOTARY PUBLIC, SIGNER(S) OF THE ABOVE OWNER'S DEDICATION AND CERTIFICATION, WHO BEING BY ME DULY SWORN, DID ACKNOWLEDGE TO ME \_\_\_\_\_ SIGNED IT FREELY, VOLUNTARILY, AND FOR THE PURPOSES THEREIN MENTIONED.

COMMISSION EXPIRES \_\_\_\_\_ NOTARY PUBLIC

### ACKNOWLEDGMENT

STATE OF UTAH ) ss.  
COUNTY OF \_\_\_\_\_ )  
ON THE \_\_\_\_\_ DAY OF \_\_\_\_\_, 20\_\_\_\_, PERSONALLY APPEARED BEFORE ME, THE UNDERSIGNED NOTARY PUBLIC, \_\_\_\_\_ BEING BY ME DULY SWORN, DID ACKNOWLEDGE TO ME THEY ARE \_\_\_\_\_ AND \_\_\_\_\_ OF SAID CORPORATION AND THAT THEY SIGNED THE ABOVE OWNER'S DEDICATION AND CERTIFICATION FREELY, VOLUNTARILY, AND IN BEHALF OF SAID CORPORATION FOR THE PURPOSES THEREIN MENTIONED.

COMMISSION EXPIRES \_\_\_\_\_ NOTARY PUBLIC

### Project Info.

Surveyor: R. KUNZ  
Designer: N. ANDERSON  
Begin Date: 07-11-12  
Name: EDGEWATER BEACH RSRT, PH 1 AMD, PRUD  
Number: 5917-15  
Revision:  
Scale: 1"=20'  
Checked:



### WEBER COUNTY PLANNING COMMISSION APPROVAL

THIS IS TO CERTIFY THAT THIS SUBDIVISION PLAT WAS DULY APPROVED BY THE WEBER COUNTY PLANNING COMMISSION. SIGNED THIS \_\_\_\_\_ DAY OF \_\_\_\_\_, 20\_\_\_\_.

CHAIRMAN, WEBER COUNTY PLANNING COMMISSION

### WEBER COUNTY ENGINEER

I HEREBY CERTIFY THAT THE REQUIRED PUBLIC IMPROVEMENT STANDARDS AND DRAWINGS FOR THIS SUBDIVISION CONFORM WITH THE COUNTY STANDARDS AND THE AMOUNT OF THE FINANCIAL GUARANTEE IS SUFFICIENT FOR THE INSTALLATION OF THESE IMPROVEMENTS.

WEBER COUNTY ENGINEER

### WEBER COUNTY COMMISSION ACCEPTANCE

THIS IS TO CERTIFY THAT THIS SUBDIVISION PLAT, THE DEDICATION OF STREETS AND OTHER PUBLIC WAYS AND FINANCIAL GUARANTEE OF PUBLIC IMPROVEMENTS ASSOCIATED WITH THIS SUBDIVISION, THEREON ARE HEREBY APPROVED AND ACCEPTED BY THE COMMISSIONERS OF WEBER COUNTY, UTAH. SIGNED THIS \_\_\_\_\_ DAY OF \_\_\_\_\_, 20\_\_\_\_.

CHAIRMAN, WEBER COUNTY COMMISSION

ATTEST

### WEBER COUNTY SURVEYOR

I HEREBY CERTIFY THAT THE WEBER COUNTY SURVEYOR'S OFFICE HAS REVIEWED THIS PLAT FOR MATHEMATICAL CORRECTNESS, SECTION CORNER DATA, AND FOR HARMONY WITH LINES AND MONUMENTS ON RECORD IN COUNTY OFFICES. THE APPROVAL OF THIS PLAT BY THE WEBER COUNTY SURVEYOR DOES NOT RELIEVE THE LICENSED LAND SURVEYOR WHO EXECUTED THIS PLAT FROM THE RESPONSIBILITIES AND/OR LIABILITIES ASSOCIATED THEREWITH. SIGNED THIS \_\_\_\_\_ DAY OF \_\_\_\_\_, 20\_\_\_\_.

WEBER COUNTY SURVEYOR

### WEBER COUNTY ATTORNEY

I HAVE EXAMINED THE FINANCIAL GUARANTEE AND OTHER DOCUMENTS ASSOCIATED WITH THIS SUBDIVISION PLAT, AND IN MY OPINION THEY CONFORM WITH THE COUNTY ORDINANCE APPLICABLE THERETO AND NOW IN FORCE AND AFFECT. SIGNED THIS \_\_\_\_\_ DAY OF \_\_\_\_\_, 20\_\_\_\_.

WEBER COUNTY ATTORNEY

### WEBER-MORGAN HEALTH DEPARTMENT

I HEREBY CERTIFY THAT THE SOILS, PERCOLATION RATES, AND SITE CONDITIONS FOR THIS SUBDIVISION HAVE BEEN INVESTIGATED BY THIS OFFICE AND ARE APPROVED FOR ON-SITE WASTEWATER DISPOSAL SYSTEMS. SIGNED THIS \_\_\_\_\_ DAY OF \_\_\_\_\_, 20\_\_\_\_.

WEBER-MORGAN HEALTH DEPARTMENT

### Webber County Recorder

Entry No. \_\_\_\_\_ Fee Paid \_\_\_\_\_  
Filed For Record \_\_\_\_\_  
And Recorded, \_\_\_\_\_  
At \_\_\_\_\_ In Book \_\_\_\_\_  
Of The Official Records, Page \_\_\_\_\_  
Recorded For: \_\_\_\_\_  
Webber County Recorder \_\_\_\_\_  
Deputy: \_\_\_\_\_



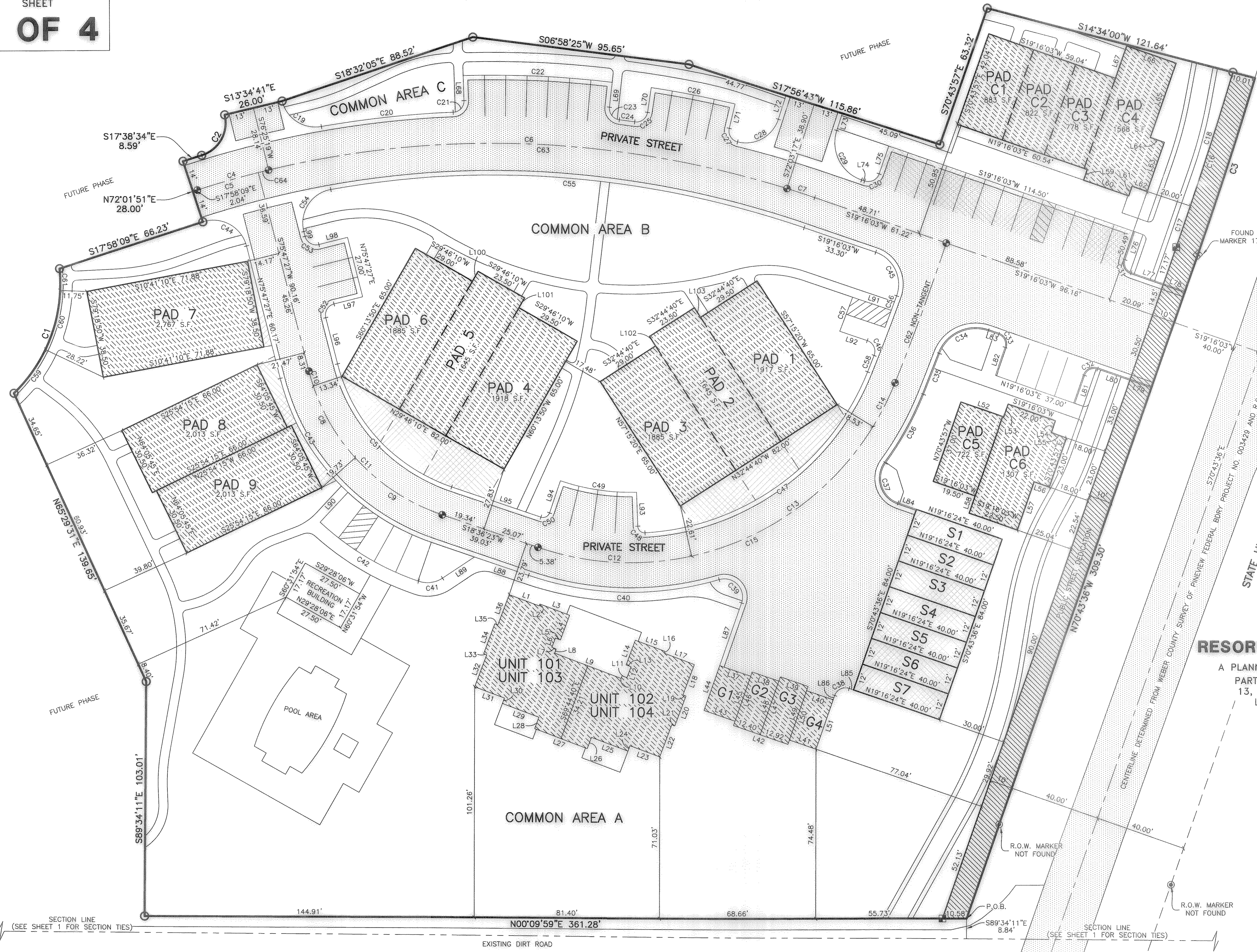

RECEIVED  
SEP 30 2014  
005087

- = SET 5/8" X 24" REBAR AND CAP STAMPED "REEVE & ASSOCIATES"
- = FOUND R.O.W. MONUMENT
- = SET R.O.W. MONUMENT
- = R.O.W. MONUMENT NOT FOUND
- = SET CL MONUMENT

- = LIMITED COMMON AREA
- = ROAD DEDICATION
- = PRIVATE OWNERSHIP
- = EXISTING PAVEMENT (COMMON AREA)
- = COMMON AREA

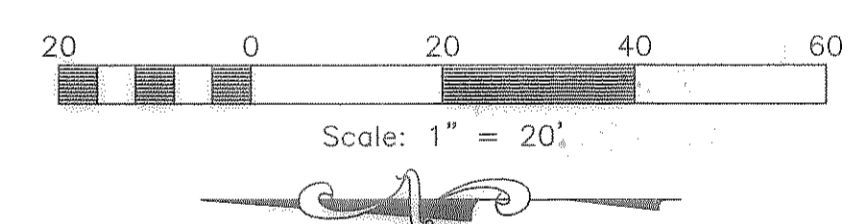

**EDGEWATER BEACH  
RESORT PHASE 1 -1ST AMENDMENT**

A PLANNED RESIDENTIAL UNIT DEVELOPMENT (P.R.U.D.)  
PART OF THE SOUTHWEST QUARTER OF SECTION  
13, TOWNSHIP 6 NORTH, RANGE 1 EAST, SALT  
LAKE BASE AND MERIDIAN, U.S. SURVEY  
WEBER COUNTY, UTAH  
AUGUST, 2012



<b>Project Info.</b>		<b>Weber County Recorder</b>	
Surveyor:	R. KUNZ	Entry No. _____	Fee Paid _____
Designer:	N. ANDERSON	And Recorded, _____	At _____ In Book _____
Begin Date:	07-11-12	Of The Official Records, Page _____	
Name:	EDGEWATER BEACH RSRT. PH 1 AMD. PRUD	Recorded For: _____	
Number:	5917-15		
Revision:			
Scale:	1"=20'		
Checked:			
		Weber County Recorder	Deputy.

SECTION LINE  
(SEE SHEET 1 FOR SECTION TIES)

SECTION LINE  
(SEE SHEET 1 FOR SECTION TIES)

EXISTING DIRT ROAD  
STREET VACATED PER ORDINANCE NO. SV01-13  
20-015-0004  
MARIAN F. MARTIN REVOCABLE TRUST



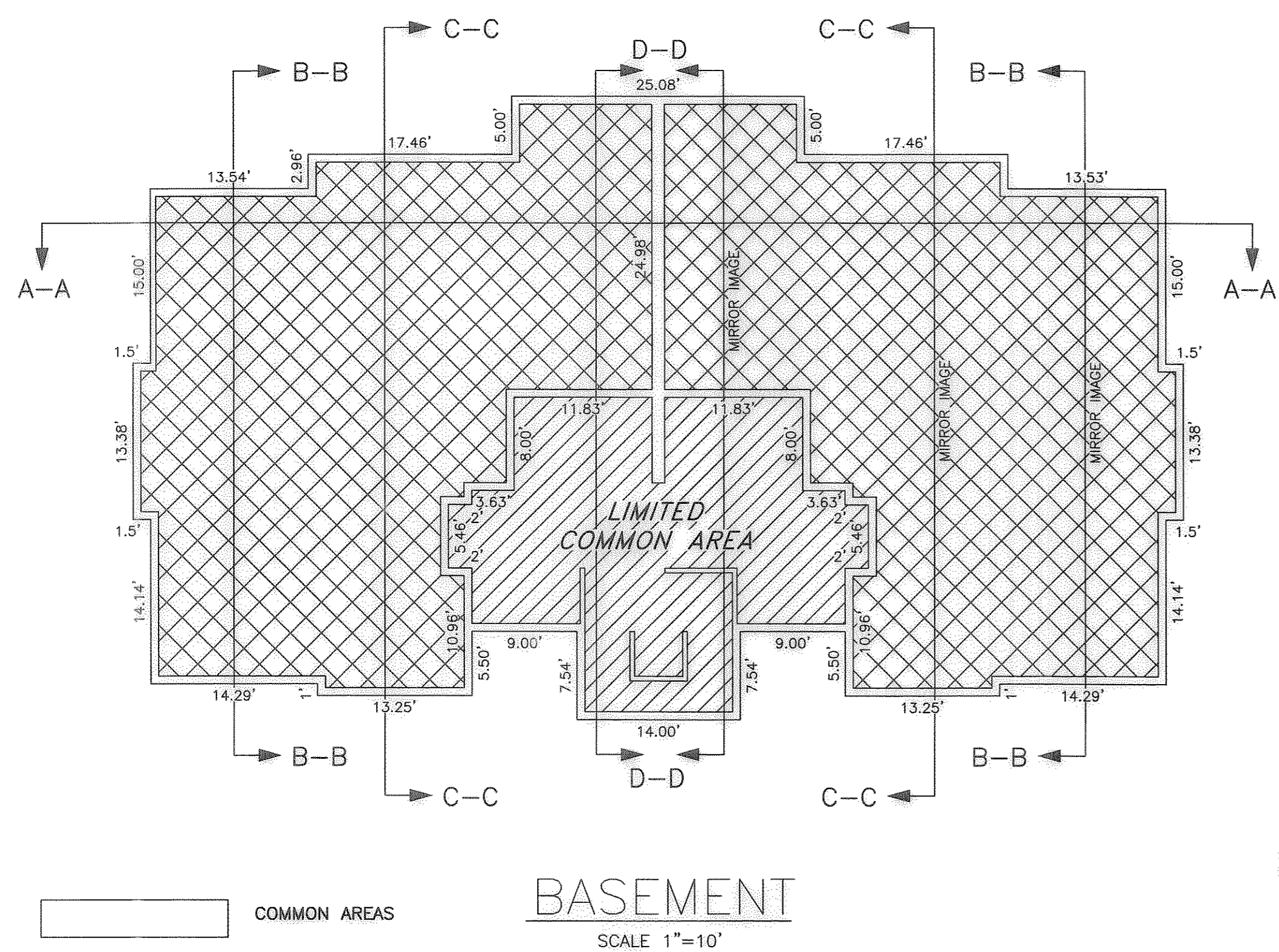
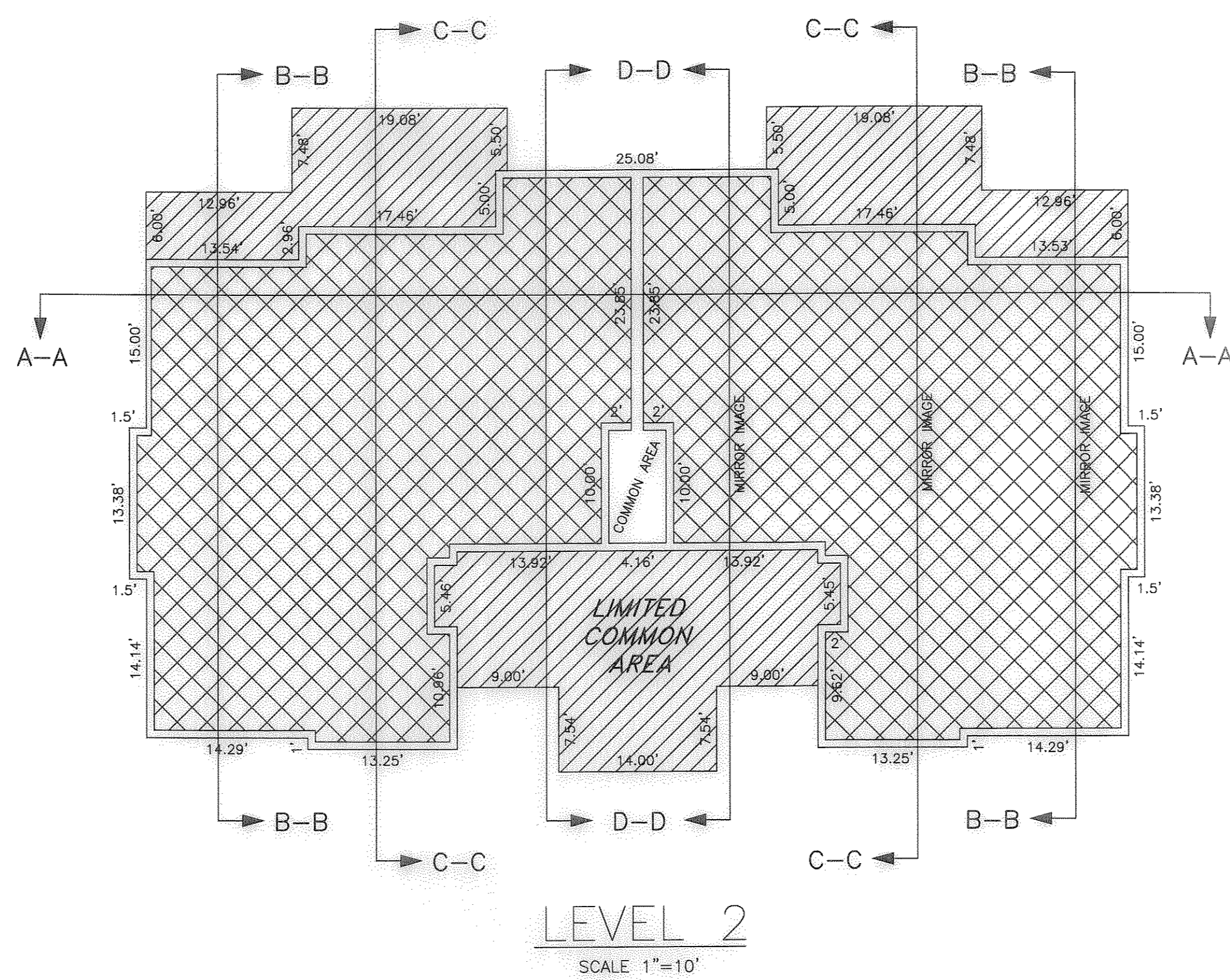
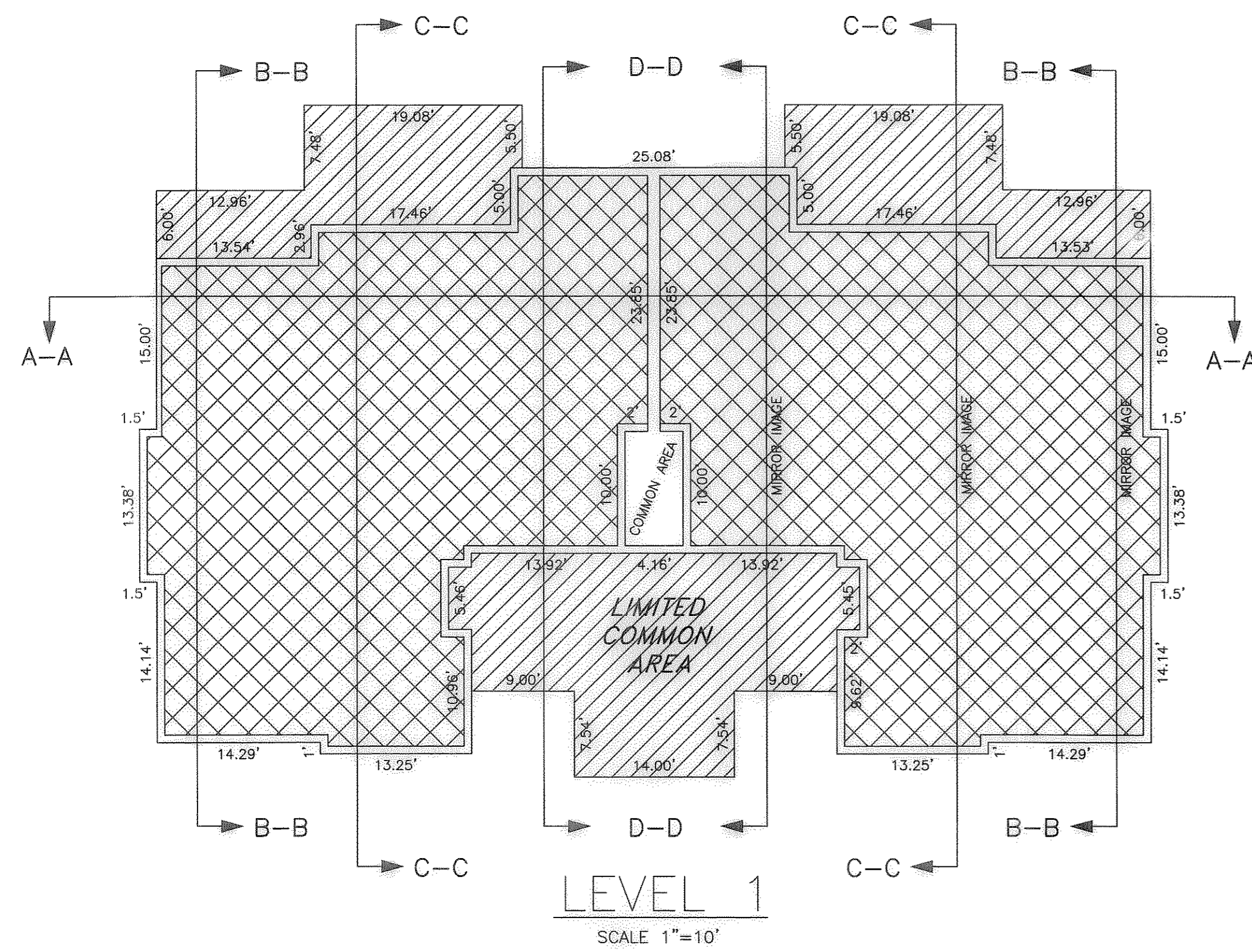

- COMMON AREAS
- LIMITED COMMON AREAS AND FACILITIES
- PRIVATE OWNERSHIP

CONDOMINIUM NOTES:  
UNITS 101-104 ARE CONDOMINIUM UNITS  
ALL DRIVEWAYS, PATIOS, DECKS, BALCONIES ON UNITS 101-104 ARE CONSIDERED LIMITED COMMON AREA. THEY ARE SET ASIDE AND RESERVED FOR THE USE OF THE RESPECTIVE CONDOMINIUM UNIT TO WHICH THEY ARE ATTACHED OR APPURTENANT.  
DIMENSIONS ON BUILDINGS VARY SLIGHTLY. AS-BUILT DIMENSIONS WILL CONTROL.

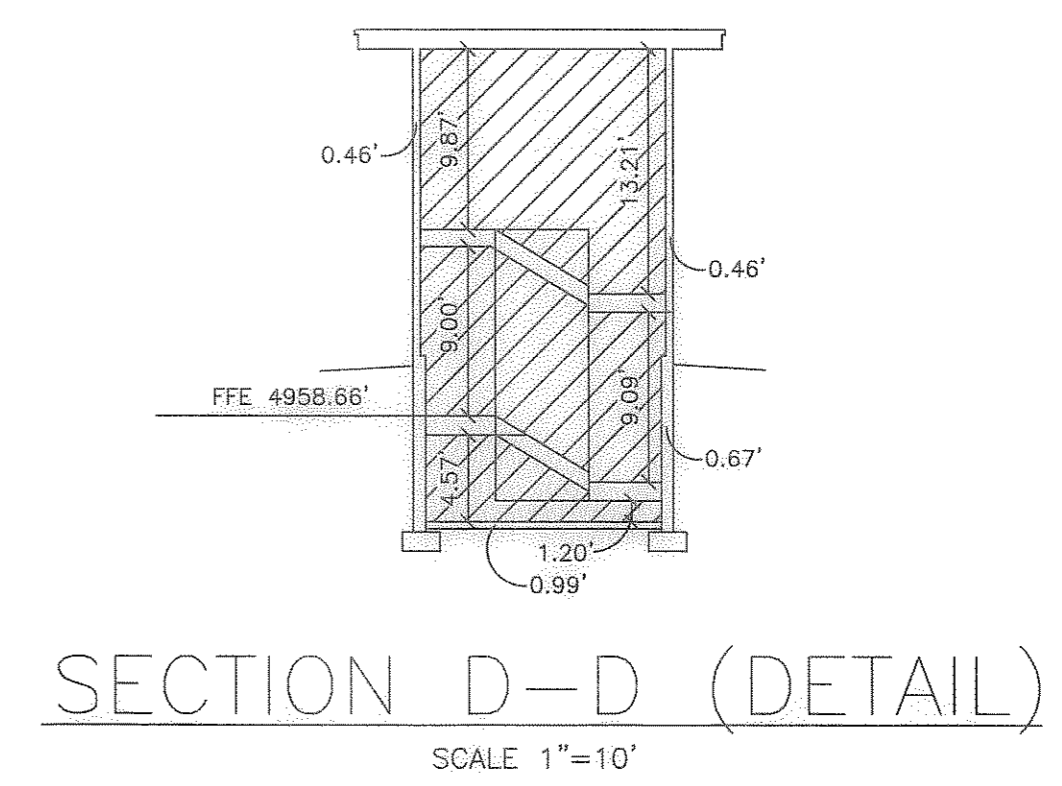
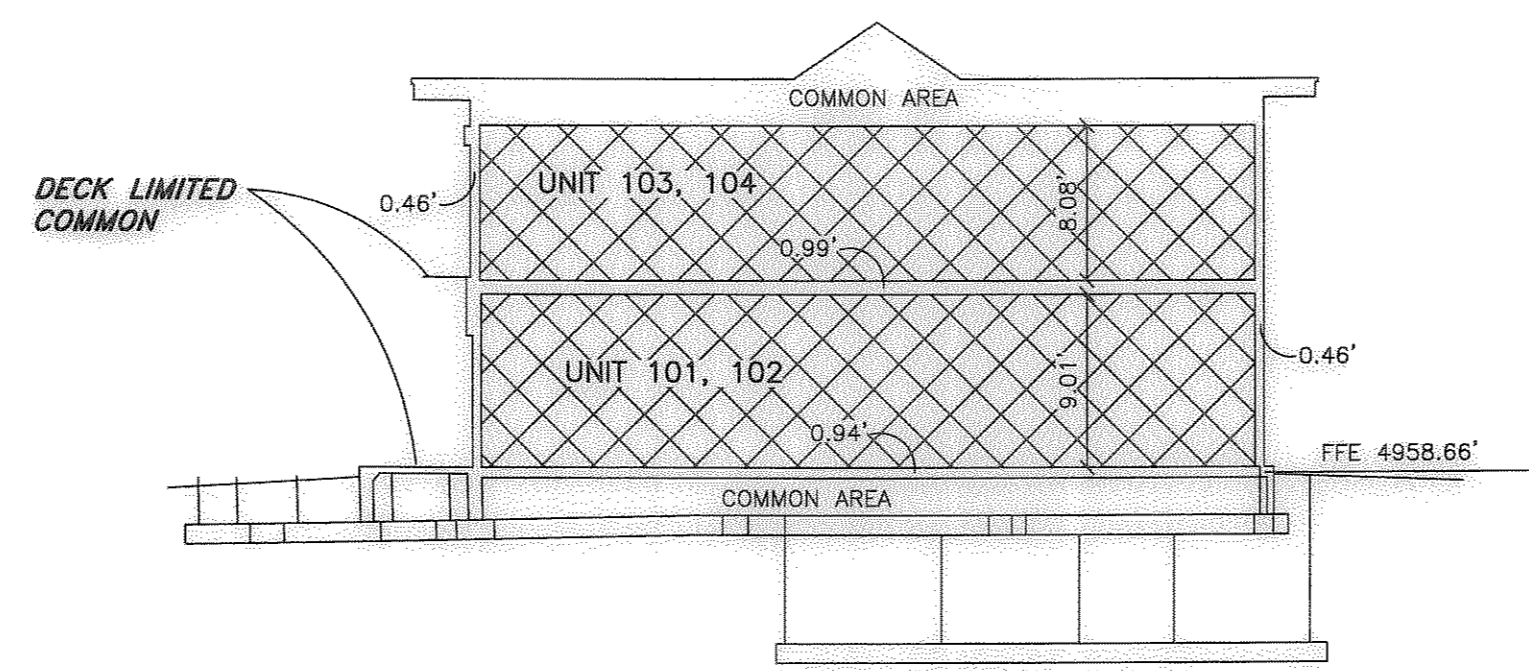
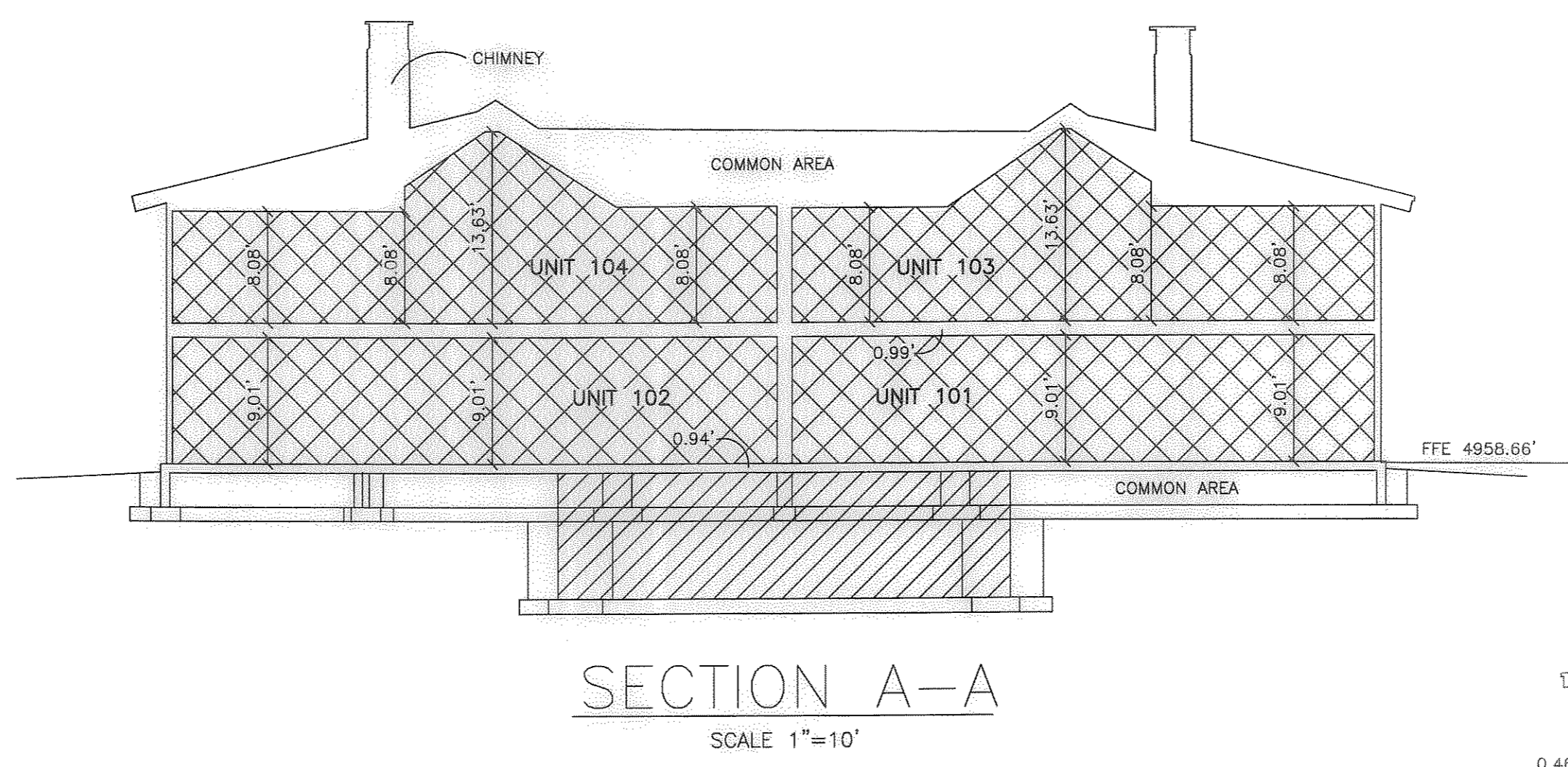
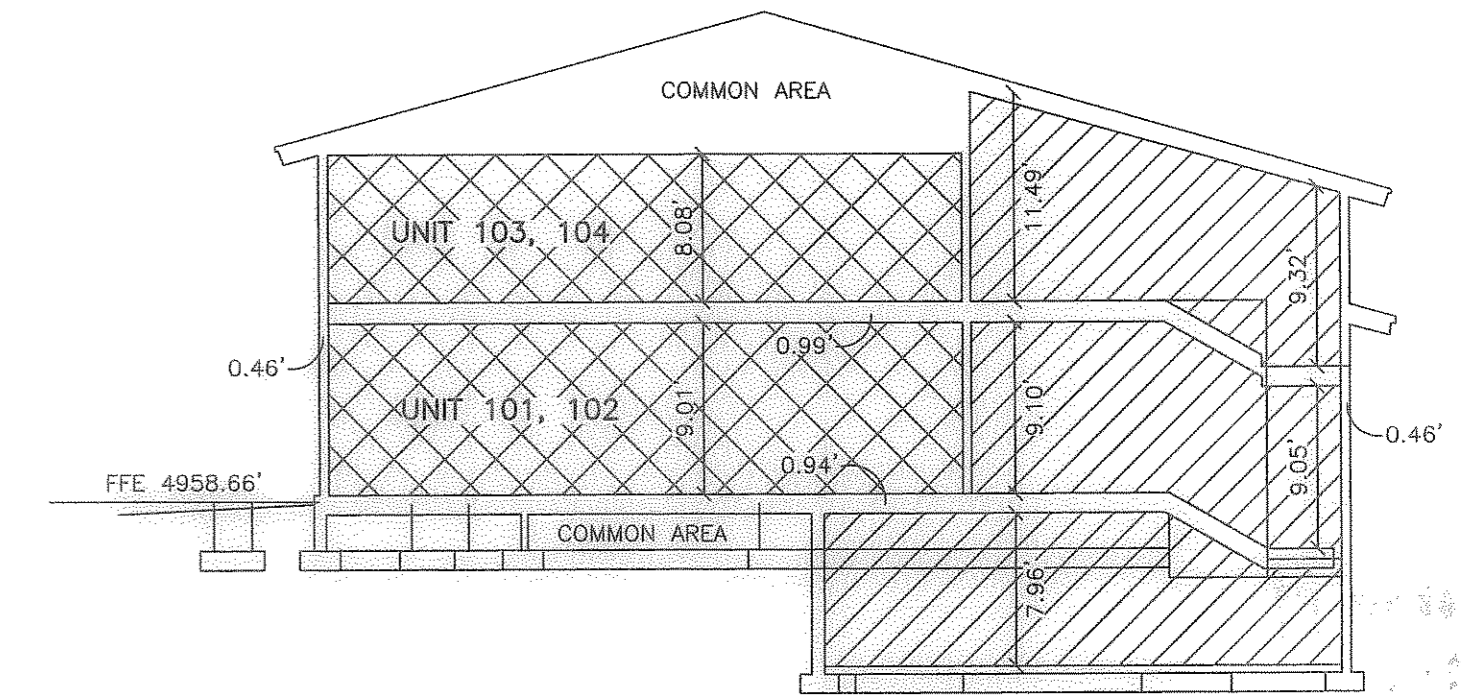
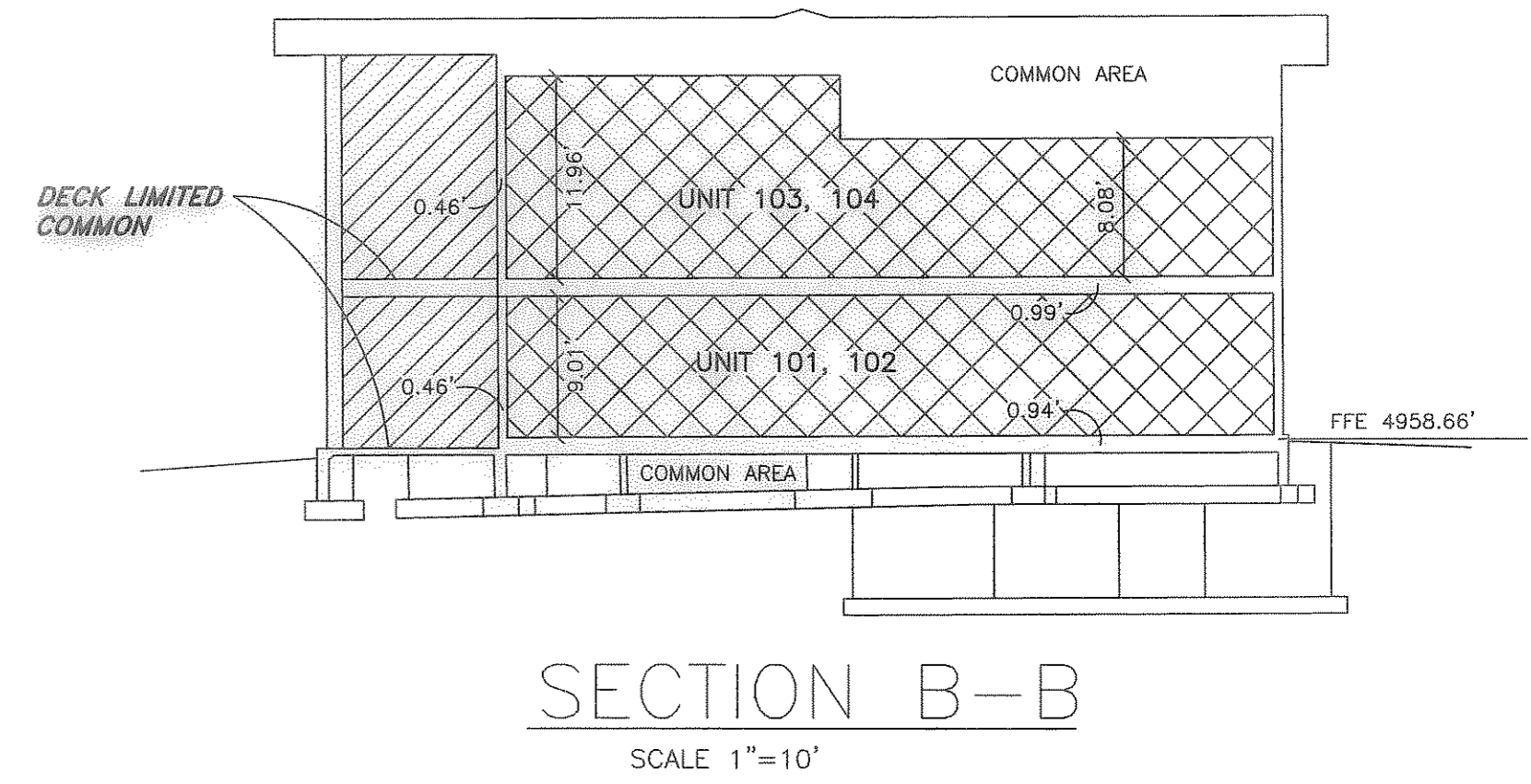

RECEIVED  
SEP 30 2014  
005087

**EDGEWATER BEACH  
RESORT PHASE 1-1ST AMENDMENT**

A PLANNED RESIDENTIAL UNIT DEVELOPMENT (P.R.U.D.)  
PART OF THE SOUTHWEST QUARTER OF SECTION  
13, TOWNSHIP 6 NORTH, RANGE 1 EAST, SALT  
LAKE BASE AND MERIDIAN, U.S. SURVEY  
WEBER COUNTY, UTAH  
AUGUST, 2012

**Reeve & Associates, Inc.**  
920 CHAMBERS STREET, SUITE 14, OGDEN, UT 84403  
TEL: (801) 621-3100 FAX: (801) 621-2666 www.reeve-assoc.com

**Project Info.**  
Surveyor: R. KUNZ  
Designer: N. ANDERSON  
Begin Date: 07-11-12  
Name: EDGEWATER BEACH  
RSRT. PH 1 AMD. PRUD  
Number: 5917-15  
Revision: 1"=10'  
Checked:

**Weber County Recorder**  
Entry No. \_\_\_\_\_ Fee Paid \_\_\_\_\_  
And Recorded, \_\_\_\_\_  
At \_\_\_\_\_ In Book \_\_\_\_\_  
Of The Official Records, Page \_\_\_\_\_  
Recorded For: \_\_\_\_\_  
Weber County Recorder  
\_\_\_\_\_ Deputy.



LINE TABLE

LINE	BEARING	DISTANCE	LINE	BEARING	DISTANCE
L1	S20°32'04"W	14.08'	L52	S19°16'03"W	20.00'
L2	S69°27'56"E	0.91'	L53	S70°43'57"E	6.00'
L3	S20°32'04"W	13.92'	L54	N70°43'57"W	5.50'
L4	N69°27'56"W	11.62'	L55	S19°16'03"W	7.04'
L5	N20°32'04"E	2.33'	L56	N19°16'03"E	7.04'
L6	N69°27'56"W	4.38'	L57	N70°43'57"E	22.54'
L7	S20°32'04"W	2.00'	L58	S70°43'57"E	8.04'
L8	S20°32'04"W	2.00'	L59	N70°43'57"W	4.96'
L9	N69°27'56"W	1.96'	L60	S19°16'03"W	21.00'
L10	N20°32'04"E	31.17'	L61	S70°43'57"E	4.50'
L11	S69°27'56"E	1.21'	L62	S19°16'03"W	7.04'
L12	S20°32'04"W	2.33'	L63	S70°43'57"E	23.00'
L13	S69°27'56"E	5.13'	L64	N19°16'03"E	6.54'
L14	N20°32'04"E	2.33'	L65	S70°43'57"E	34.54'
L15	S69°27'56"E	11.62'	L66	N19°16'03"E	23.00'
L16	S20°32'04"W	13.92'	L67	N70°43'57"W	15.04'
L17	N69°27'56"W	0.91'	L68	N88°13'22"E	11.03'
L18	S20°32'04"W	14.08'	L69	S83°31'02"E	11.03'
L19	N69°27'56"W	14.25'	L70	S81°20'15"E	11.03'
L20	S20°32'04"W	1.42'	L71	S78°37'03"E	11.03'
L21	N69°27'56"W	14.04'	L72	S72°03'17"E	10.95'
L22	N20°32'04"E	1.42'	L73	S72°03'17"E	7.91'
L23	N69°27'56"W	15.08'	L74	N19°16'03"E	1.41'
L24	N20°32'04"E	13.96'	L75	N70°43'57"W	13.00'
L25	N69°27'56"W	2.54'	L76	N70°43'57"W	13.00'
L26	N20°32'04"E	17.13'	L77	S19°16'03"W	15.00'
L27	N69°27'56"W	5.33'	L78	S19°16'03"W	10.00'
L28	N20°32'04"E	24.67'	L79	S19°16'03"W	10.00'
L29	S69°27'56"E	5.33'	L80	S19°16'03"W	15.00'
L30	N20°32'04"E	17.13'	L81	S70°43'57"E	13.00'
L31	S69°27'56"E	2.54'	L82	S70°43'57"E	13.00'
L32	N20°32'04"E	13.96'	L83	S19°16'03"W	4.94'
L33	S69°27'56"E	15.08'	L84	N19°16'24"E	8.53'
L34	N20°32'04"E	1.42'	L85	N19°16'24"E	2.04'
L35	S69°27'56"E	14.04'	L86	N70°43'36"W	2.00'
L36	S20°32'04"W	1.42'	L87	S70°43'36"E	29.16'
L37	S69°27'56"E	14.25'	L88	N18°36'23"E	25.10'
L38	S19°16'24"W	14.40'	L89	N33°36'23"W	16.89'
L39	S19°16'24"W	12.40'	L90	S47°03'23"E	18.00'
L40	S19°16'24"W	12.92'	L91	N19°16'03"E	18.00'
L41	S19°16'24"W	12.40'	L92	S19°16'03"W	12.82'
L42	N19°16'24"E	12.40'	L93	N88°06'02"E	14.96'
L43	N19°16'24"E	25.31'	L94	N71°23'37"W	15.00'
L44	N19°16'24"E	14.40'	L95	N18°36'23"E	41.41'
L45	S70°43'36"E	20.92'	L96	N75°47'27"E	20.97'
L46	S70°43'36"E	20.92'	L97	S14°12'33"E	13.00'
L47	S70°43'36"E	24.92'	L98	N14°12'33"W	13.00'
L48	S70°43'36"E	26.92'	L99	N75°47'27"E	2.19'
L49	S70°43'36"E	24.92'	L100	S60°13'50"E	5.00'
L50	S70°43'36"E	22.92'	L101	N60°13'50"W	5.00'
L51	S70°43'36"E	22.92'	L102	N57°15'20"E	5.00'
			L103	S57°15'20"W	5.00'

CURVE TABLE

#	RADIUS	ARC LENGTH	CHD LENGTH	TANGENT	CHD BEARING	DELTA
C1	66.72'	60.50'	58.45'	32.51'	S69°52'48"E	51°57'15"
C2	15.00'	22.64'	20.55'	14.10'	S60°20'46"E	86°27'51"
C3	1869.86'	81.69'	81.68'	40.85'	N71°58'42"W	2°30'11"
C4	425.00'	32.57'	32.56'	16.29'	S15°46'25"E	4°23'28"
C5	425.00'	27.89'	27.89'	13.95'	S16°05'21"E	3°45'36"
C6	425.00'	230.83'	228.00'	118.34'	S01°58'53"W	31°07'08"
C7	425.00'	12.81'	12.81'	6.40'	S18°24'15"W	1°43'36"
C8	90.00'	43.52'	43.10'	22.20'	S61°56'13"W	27°42'30"
C9	90.00'	46.30'	45.79'	23.68'	S33°20'41"W	29°28'35"
C10	90.00'	6.80'	6.80'	3.40'	S73°37'31"W	4°19'53"
C11	90.00'	83.02'	80.11'	44.73'	S45°01'59"W	52°51'12"
C12	126.00'	68.42'	67.59'	35.08'	S03°02'57"W	31°06'52"
C13	126.00'	100.54'	97.90'	53.12'	S35°22'03"E	45°43'09"
C14	126.00'	21.50'	21.47'	10.77'	S63°06'53"E	9°46'32"
C15	126.00'	190.46'	172.84'	118.76'	S24°41'53"E	86°36'33"
C16	1859.86'	80.87'	80.86'	40.44'	S71°58'20"E	2°29'28"
C17	1859.86'	19.03'	19.03'	9.51'	S71°01'11"E	0°35'10"
C18	1859.86'	61.84'	61.84'	30.92'	S72°15'55"E	1°54'18"
C19	15.00'	22.64'	20.55'	14.10'	S33°11'24"W	86°27'51"
C20	439.00'	58.38'	58.34'	29.23'	N06°13'56"W	7°37'11"
C21	5.00'	7.80'	7.03'	4.94'	S47°05'59"E	89°21'17"
C22	455.00'	65.59'	65.54'	32.85'	N02°21'10"E	8°15'36"
C23	5.00'	7.80'	7.03'	4.94'	S61°48'20"W	89°21'17"
C24	439.00'	6.81'	6.81'	3.41'	N07°34'21"E	0°53'21"
C25	5.00'	7.80'	7.03'	4.94'	S36°39'37"E	89°21'17"
C26	455.00'	37.48'	37.47'	18.75'	N11°01'21"E	4°43'12"
C27	5.00'	7.80'	7.03'	4.94'	S58°42'18"W	89°21'17"
C28	15.00'	22.54'	20.48'	14.01'	S29°00'45"E	86°05'05"
C29	17.50'	27.09'	24.46'	17.10'	S63°36'23"W	88°40'40"
C30	5.00'	7.85'	7.07'	5.00'	S25°43'57"E	90°00'00"
C31	4.50'	7.07'	6.36'	4.50'	S64°16'03"W	90°00'00"
C32	4.50'	7.07'	6.36'	4.50'	N25°43'57"W	90°00'00"
C33	4.50'	7.07'	6.36'	4.50'	N64°16'03"E	90°00'00"
C34	17.00'	26.21'	23.69'	16.52'	N24°54'15"W	88°20'36"
C35	1025.00'	19.24'	19.24'	9.62'	N68°32'18"W	1°04'31"
C36	140.00'	34.56'	34.48'	17.37'	N60°55'41"W	14°08'43"
C37	11.50'	21.45'	18.47'	15.50'	N72°42'32"E	106°52'17"
C38	5.00'	7.85'	7.07'	5.00'	N25°43'36"W	90°00'00"
C39	8.00'	17.56'	14.24'	15.61'	N46°24'10"E	125°44'29"
C40	139.00'	85.09'	83.77'	43.93'	N01°04'09"E	35°04'28"
C41	12.00'	10.99'	10.61'	5.92'	N07°21'48"W	52°29'10"
C42	121.00'	50.51'	50.15'	25.63'	N30°59'02"E	23°55'11"
C43	103.00'	59.05'	58.24'	30.36'	N59°22'02"E	32°50'51"
C44	15.00'	24.55'	21.90'	16.02'	N28°54'39"E	93°45'36"
C45	15.00'	23.74'	21.34'	15.18'	S64°36'22"W	90°40'38"
C46	5.00'	8.05'	7.21'	5.20'	S65°24'37"W	92°17'08"
C47	113.00'	127.29'	120.66'	71.35'	N35°43'57"W	64°32'26"
C48	3.00'	4.79'	4.30'	3.08'	N42°19'09"E	91°33'46"
C49	95.00'	34.00'	33.82'	17.18'	N08°21'13"E	20°30'21"
C50	3.00'	4.71'	4.24'	3.00'	N26°23'37"W	90°00'00"
C51	77.00'	76.85'	73.70'	41.97'	N47°11'55"E	57°11'04"
C52	5.00'	7.85'	7.07'	5.00'	S59°12'33"E	90°00'00"
C53	5.00'	7.85'	7.07'	5.00'	N30°47'27"E	90°00'00"
C54	15.00'	24.62'	21.95'	16.10'	S57°10'54"E	94°03'17"
C55	41.00'	211.05'	208.74'	107.91'	S04°33'24"W	29°25'19"
C56	998.50'	6.82'	6.82'	3.41'	N69°51'35"W	0°23'30"
C57	980.50'	16.01'	16.01'	8.00'	N69°10'36"W	0°56'07"
C58	998.50'	7.74'	7.74'	3.87'	N68°13'29"W	0°26'39"
C59	66.72'	23.73'	23.61'	11.99'	S54°05'34"E	20°22'47"
C60	66.72'	27.08'	26.90'	13.73'	S75°54'42"E	23°15'28"
C61	66.72'	9.68'	9.68'	4.85'	N88°18'04"E	8°18'59"
C62	1011.50'	65.57'	65.56'	32.80'	S69°51'35"E	3°42'51"
C63	425.00'	243.64'	240.31'	125.27'	S02°50'41"W	32°50'44"
C64	425.00'	4.68'	4.68'	2.34'	S13°53'37"E	0°37'51"



EDGEWATER BEACH  
RESORT PHASE 1 -1ST AMENDMENT

A PLANNED RESIDENTIAL UNIT DEVELOPMENT (P.R.U.D.)  
PART OF THE SOUTHWEST QUARTER OF SECTION  
13, TOWNSHIP 6 NORTH, RANGE 1 EAST, SALT  
LAKE BASE AND MERIDIAN, U.S. SURVEY  
WEBER COUNTY, UTAH  
AUGUST, 2012



<p><b>Project Info.</b></p> <p>Surveyor: R. KUNZ</p> <p>Designer: N. ANDERSON</p> <p>Begin Date: 07-11-12</p> <p>Name: EDGEWATER BEACH RSRT. PH 1 AMD. PRUD</p> <p>Number: 5917-15</p> <p>Revision:</p> <p>Scale: 1"=10'</p> <p>Checked:</p>	<p><b>Weber County Recorder</b></p> <p>Entry No. _____ Fee Paid _____</p> <p>At _____ Filed For Record _____</p> <p>At _____ In Book _____</p> <p>Of The Official Records, Page _____</p> <p>Recorded For: _____</p> <p>_____ Weber County Recorder</p> <p>_____ Deputy.</p>
--	--