

**PARCEL A
BOUNDARY DESCRIPTION**

A PART OF THE SOUTHEAST QUARTER OF SECTION 35, TOWNSHIP 7 NORTH, RANGE 2 WEST, OF THE SALT LAKE BASE AND MERIDIAN. BEGINNING AT A POINT ALONG THE WEST RIGHT-OF-WAY LINE OF 2000 WEST STREET BEING LOCATED NORTH 89°10'39" WEST 795.15 FEET ALONG THE SOUTH LINE OF SAID SOUTHEAST QUARTER AND NORTH 1°32'42" EAST 462.41 FEET FROM THE NORTHEAST CORNER OF SAID SOUTHEAST QUARTER; RUNNING THENCE SOUTH 83°03'24" WEST 455.28 FEET; THENCE NORTH 1°07'00" EAST 406.06 FEET TO A FENCE LINE PROJECTED; THENCE ALONG SAID FENCE SOUTH 89°24'30" EAST 283.13 FEET; THENCE SOUTH 1°22'29" WEST 152.08 FEET; THENCE SOUTH 88°10'42" EAST 169.78 FEET TO THE WEST RIGHT-OF-WAY LINE OF 2000 SOUTH STREET; THENCE ALONG SAID RIGHT-OF-WAY LINE SOUTH 1°32'42" WEST 190.66 FEET TO THE POINT OF BEGINNING. CONTAINING 143,870 SQ FT OR 3.301 ACRES.

NARRATIVE:

THE PURPOSE OF THE SURVEY WAS TO ESTABLISH THE BOUNDARY OF THE PARCELS AS SHOWN AND DESCRIBED HEREON. NO DEVELOPMENT CAN OCCUR UNTIL THE PARCEL GOES THROUGH THE PROPER SUBDIVISION PROCESS AND GETS APPROVAL FROM THE GOVERNING MUNICIPALITY. THE SURVEY WAS ORDERED BY WILLIAM FOX. THE CONTROL USED TO ESTABLISH THE BOUNDARY WAS THE EXISTING WEBER COUNTY SURVEY MONUMENTATION AS SHOWN AND NOTED HEREON. THE BASIS OF BEARING IS THE SOUTH LINE OF THE SOUTHEAST QUARTER OF SECTION 35, TOWNSHIP 7 NORTH, RANGE 2 WEST, OF THE SALT LAKE BASE AND MERIDIAN WHICH BEARS NORTH 89°10'39" WEST WEBER COUNTY GRID BEARING.

REVISIONS	DATE	DESCRIPTION

DATE	DESCRIPTION

PROPERTY SURVEY FOR WILLIAM FOX
1975 NORTH 2000 WEST, FARR WEST, UTAH
LOCATED IN THE SOUTHEAST QUARTER OF SECTION 35,
TOWNSHIP 7 NORTH, RANGE 2 WEST, S.L.B. AND M.

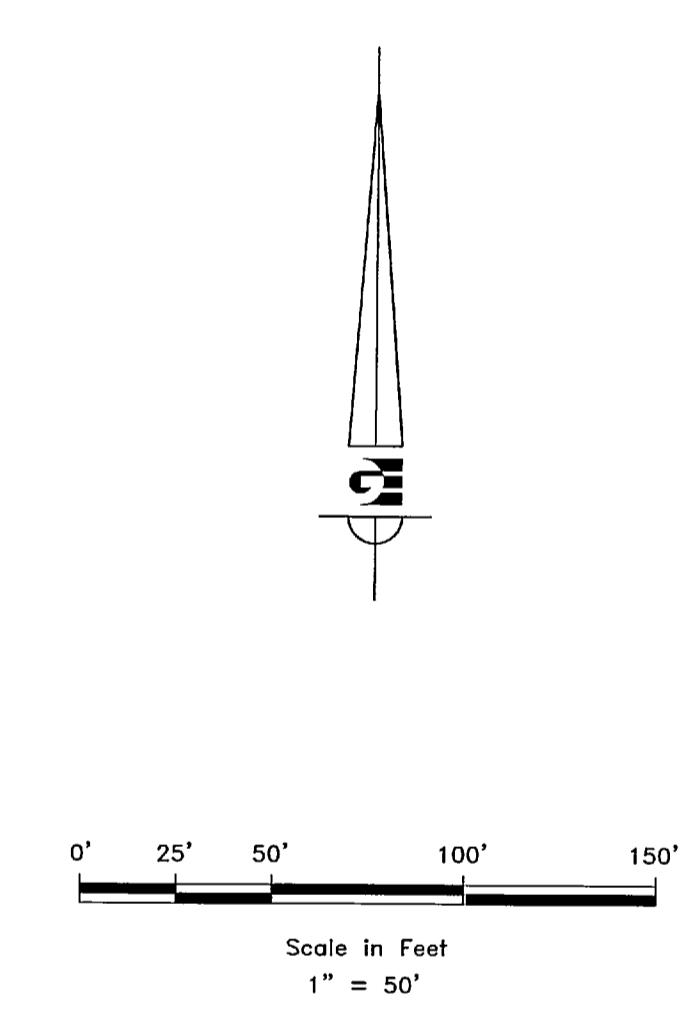

- WEBER COUNTY MONUMENT AS NOTED
- SET 24" REBAR AND CAP MARKED GARDNER ENGINEERING
- PROPERTY LINE
- ADJACENT PARCEL
- SECTION LINE
- EXISTING FENCE

SURVEYOR'S CERTIFICATE

I, KLINT H. WHITNEY, DO HEREBY CERTIFY THAT I AM A LICENSED PROFESSIONAL LAND SURVEYOR IN THE STATE OF UTAH AND THAT I HOLD CERTIFICATE NO. 8227228 IN ACCORDANCE WITH TITLE 58, CHAPTER 22, OF THE PROFESSIONAL ENGINEERS AND LAND SURVEYORS ACT; I FURTHER CERTIFY THAT BY AUTHORITY OF THE OWNERS I HAVE COMPLETED A SURVEY OF THE PROPERTY DESCRIBED ON THIS RECORD OF SURVEY PLAT IN ACCORDANCE WITH SECTION 17-23-17 AND HAVE VERIFIED ALL MEASUREMENTS; THAT THE REFERENCE MONUMENTS SHOWN ON THIS RECORD OF SURVEY PLAT ARE LOCATED AS INDICATED AND ARE SUFFICIENT TO RETRACE OR REESTABLISH THIS SURVEY; AND THAT THE INFORMATION SHOWN HEREIN IS SUFFICIENT TO ACCURATELY ESTABLISH THE LATERAL BOUNDARIES OF THE HEREIN DESCRIBED TRACT OF REAL PROPERTY.

SIGNED THIS 19TH DAY OF MARCH, 2015.

SOUTHEAST CORNER
SEC.35, T7N, R2W, S.L.B&M.
(FOUND BRASS CAP GOOD CONDITION)

SOUTH QUARTER CORNER
SEC.35, T7N, R2W, S.L.B&M.
(FOUND BRASS CAP GOOD CONDITION)

RECEIVED
MAR 23 2015
By 005182

PROFESSIONAL LAND SURVEYOR
8227228
Klint H. Whitney
STATE OF UTAH
KLINT H. WHITNEY, PLS NO. 8227228

GARDNER ENGINEERING
CIVIL - LAND PLANNING
MUNICIPAL - LAND SURVEYING

SI
1