

LEGEND

	Subject Property Line
	Adjoining Property Line
	Centerline
	Ditch
	Fence Line (Wire/Wood)
	Fence Line (wood or Vinyl)
	Street Monument
	Found rebar set by others
	Set 5/8"x24" Rebar With Cap
	Section Corner

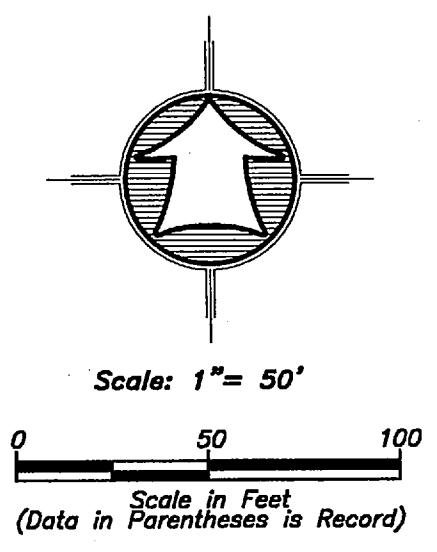

Narrative

The purpose of this survey was to establish and set the property corners of the parcel as shown and described hereon. The survey was ordered by Angelica Shafer. The control used to establish the property corners was the existing Ogden City Survey Monumentation surrounding Block 66, Plat "C" of the Ogden City Survey. The basis of bearing is the Center line of 15th Street from the monument at Liberty Ave. to the monument at Jefferson Ave. which bears North N 88°41'40" West, Utah North, State Plane, Calculated N.A.D.83 Bearing.

As-Recorded Description

PART OF LOT 7, BLOCK 66, PLAT C, OGDEN CITY SURVEY, WEBER COUNTY, UTAH: BEGINNING NORTH 89°02' WEST 62.5 FEET FROM THE NORTHWEST CORNER OF STONE'S ORCHARD ADDITION, OGDEN CITY, WEBER COUNTY, UTAH; THENCE NORTH 89°02' WEST ALONG SOUTH LINE OF 15TH STREET 62.5 FEET; THENCE SOUTH 00°58' WEST 150 FEET; THENCE SOUTH 89°02' EAST 62.5 FEET; THENCE NORTH 00°58' EAST 150 FEET TO BEGINNING.

SURVEYOR'S CERTIFICATE

I, K. Greg Hansen, do hereby Certify that I am a Registered Professional Land Surveyor in the State of Utah in Accordance with Title 58, Chapter 22, Professional Engineers and Land Surveyors Act; and by the Authority of the Owners, I have Completed a Survey of the Property Described and shown Hereon this Plat in Accordance with Section 17-23-17 and have Verified all Measurements, and that the same has been Surveyed and Monuments have been Located and/or Placed on the Ground as Represented on the plat Hereon.

Signed this 13th day of Sept, 2015

K. Greg Hansen PLS
Utah Land Surveyor Licence No. 167819

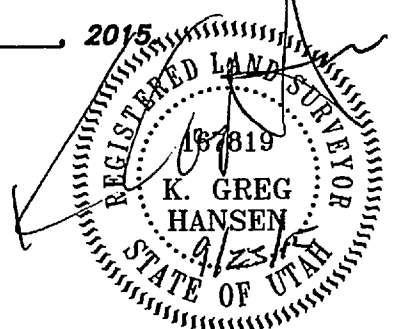

No.	Date	By	Revision

HANSEN & ASSOCIATES, INC.
Consulting Engineers and Land Surveyors
538 North Main Street, Brigham, Utah 84302
Visit us at www.haes.net
Logan Ogden
Brigham City
(435) 723-3491 (801) 399-4905 (435) 752-8272



Drawn By: kgh Date: 07/07/15
Designed By: _____
Checked By: _____
Approved By: _____
Scale: 1" = 50'
Drawing File: 15-3-125v15
JOB NUMBER: 15-3-125

Property Survey for
Angelica Shafer
703 15th Street
Ogden City, Weber County, Utah
A Part of the Southwest Quarter of
Section 21, T 6 N., R 1 W., S.L.B.&M.

Sheet
1
Of
1
Sheets