

- Legend**
- Subject Property Line
  - - - - - Adjoining Property Line
  - Centerline
  - - - - - Field Separation Line
  - x - x - - - - - Fence Line (Wire)
  - o - o - - - - - Fence Line (wood or Vinyl)
  - ⊙ Street Monument
  - ⊙ Found rebar set by others
  - ⊙ Set 5/8"x24" Rebar With Cap

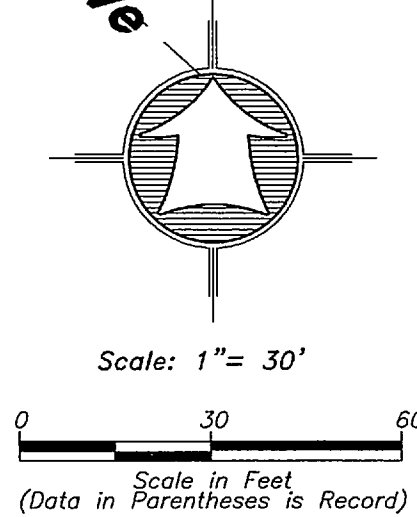

**Narrative**

The purpose of this survey was to establish and set the property corners of the parcels as shown and described hereon. The survey was ordered by Craig Sears, Real Property Business Manager for Weber State University. The control used to establish the property corners was the existing Street Survey Monumentation found within the Naisbitt Subdivision along 4225 South Street. The basis of bearing is the centerline of said 4225 South Street which bears North 89°57'52" East, the bearing shown on said subdivision plat.

**As Recorded Descriptions**

ALL OF LOT 4, NAISBITT SUBDIVISION, WEBER COUNTY, UTAH AND  
 ALL OF LOT 6, NAISBITT SUBDIVISION, WEBER COUNTY, UTAH.

**SURVEYOR'S CERTIFICATE**

I, K. Greg Hansen, do hereby certify that I am a Registered Professional Land Surveyor in the State of Utah in accordance with Title 58, Chapter 22, Professional Engineers and Land Surveyors Act; and by the Authority of the Owners, I have Completed a Survey of the Property Described and shown Hereon this Plat in Accordance with Section 17-23-17 and have Verified all Measurements, and that the same has been Surveyed and Monuments have been Located and/or Placed on the Ground as Represented on the plat Hereon.

Signed this 21<sup>st</sup> day of DECEMBER, 2015.

K. Greg Hansen PLS  
 Utah Land Surveyor Licence No. 167819

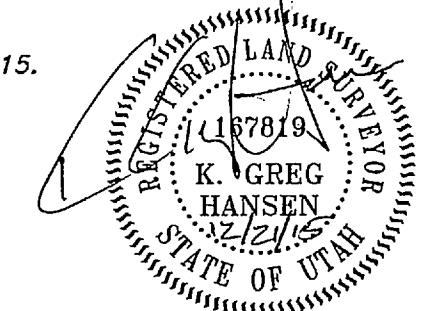

JAN 19 2016  
 5400

<p>Property Survey for  <b>Weber State Univ.</b>          1348 East and 1361 East 4225 South          Ogden City, Weber County Co., Utah          A Part of the Northwest Quarter of          Section 10, T 5 N., R 1 W., S.L.B.&amp;M.</p>		<p>Drawn By: kgh Date: 12/14/15          Designed By:          Checked By:          Approved By:          Scale: 1" = 30'          Drawing File: 15-3-221v15          JOB NUMBER: 15-3-221</p>																																								
<p>HANSEN &amp; ASSOCIATES, INC.          Consulting Engineers and Land Surveyors          538 North Main Street, Brigham, Utah 84302          Visit us at www.hais.net          Ogden Logan          Brigham City (801) 399-4905 (435) 752-8272</p>		<table border="1"> <tr><th>No.</th><th>Date</th><th>By</th><th>Revision</th></tr> <tr><td> </td><td> </td><td> </td><td> </td></tr> <tr><td> </td><td> </td><td> </td><td> </td></tr> <tr><td> </td><td> </td><td> </td><td> </td></tr> <tr><td> </td><td> </td><td> </td><td> </td></tr> <tr><td> </td><td> </td><td> </td><td> </td></tr> <tr><td> </td><td> </td><td> </td><td> </td></tr> <tr><td> </td><td> </td><td> </td><td> </td></tr> <tr><td> </td><td> </td><td> </td><td> </td></tr> <tr><td> </td><td> </td><td> </td><td> </td></tr> </table>	No.	Date	By	Revision																																				
No.	Date	By	Revision																																							
<p>Sheet  <b>1</b>          Of  <b>1</b>          Sheets</p>																																										