

Second Amendment to the
Lot Line Adjustment for:

Tim Thomas

2012 North Mountain Road
North Ogden, Utah

A PART OF THE SOUTHWEST QUARTER OF SECTION 34,
TOWNSHIP 7 NORTH, RANGE 1 WEST, S.L.B.& M.

Parcel 1
A PART OF THE SOUTHWEST QUARTER OF SECTION 34, TOWNSHIP 7 NORTH, RANGE 1 WEST OF THE SALT LAKE BASE AND MERIDIAN. BEGINNING AT A POINT ON THE EAST RIGHT-OF-WAY LINE OF MOUNTAIN ROAD LOCATED SOUTH 89°18'12" EAST 482.67 FEET ALONG THE SOUTH LINE OF THE SAID SOUTHWEST QUARTER AND NORTH 44°05'48" EAST 890.70 FEET AND SOUTH 45°54'12" EAST 26.06 FEET FROM THE SOUTHWEST CORNER OF THE SAID SOUTHWEST QUARTER; RUNNING THENCE NORTH 40°43'13" EAST 208.16 FEET ALONG SAID EAST RIGHT-OF-WAY LINE; THENCE SOUTH 49°50'38" EAST 131.68 FEET; THENCE SOUTH 85°42'46" EAST 49.40 FEET; THENCE NORTH 23°18'21" EAST 444.09 FEET; THENCE NORTH 62°19'38" WEST 61.74 FEET TO THE SAID EAST RIGHT-OF-WAY LINE; THENCE ALONG SAID EAST RIGHT-OF-WAY LINE THE FOLLOWING TWO (2) COURSES: (1) NORTH 37°46'27" EAST 159.99 FEET; AND (2) NORTH 21°47'36" EAST 18.08 FEET TO THE SOUTH LINE OF THE KENNETH MURPHEY PROPERTY; THENCE SOUTH 89°18'12" EAST 224.21 FEET ALONG SAID SOUTH PROPERTY LINE TO THE WEST LINE OF THE OGDEN BRIGHAM CANAL; RUNNING THENCE ALONG SAID WEST LINE THE FOLLOWING THIRTEEN (13) COURSES: (1) SOUTH 23°01'46" WEST 23.56 FEET; (2) TO THE LEFT ALONG THE ARC OF A 160.00 FOOT RADIUS CURVE A DISTANCE OF 79.85 FEET; CHORD BEARS SOUTH 08°19'01" WEST 79.02 FEET; (3) SOUTH 05°58'47" EAST 46.04 FEET; (4) TO THE RIGHT ALONG THE ARC OF A 40 FOOT RADIUS CURVE A DISTANCE OF 18.90 FEET; CHORD BEARS SOUTH 07°13'03" WEST 18.72 FEET; (5) SOUTH 20°45'13" WEST 61.89 FEET; (6) TO THE LEFT ALONG THE ARC OF A 560.00 FOOT RADIUS CURVE A DISTANCE OF 124.00 FEET; CHORD BEARS SOUTH 14°25'50" WEST 123.75 FEET; (7) SOUTH 08°05'13" WEST 3.52 FEET; (8) SOUTH 81°54'47" EAST 10.00 FEET; (9) SOUTH 08°05'13" WEST 24.38 FEET; (10) TO THE RIGHT ALONG THE ARC OF A 950.00 FOOT RADIUS CURVE A DISTANCE OF 64.42 FEET; CHORD BEARS SOUTH 10°01'39" WEST 64.41 FEET; (11) SOUTH 11°58'13" WEST 90.50 FEET; (12) TO THE LEFT ALONG THE ARC OF A 1050.00 FOOT RADIUS CURVE A DISTANCE OF 82.45 FEET; CHORD BEARS SOUTH 09°42'41" WEST 82.45 FEET; (13) SOUTH 07°27'49" WEST 49.98 FEET TO THE NORTH LINE OF THE DAVID WILLOUGHBY PROPERTY; THENCE NORTH 89°18'12" WEST 620.29 FEET ALONG SAID NORTH PROPERTY LINE TO THE POINT OF BEGINNING. CONTAINING 4.966 ACRES.

Parcel 2
A PART OF THE SOUTHWEST QUARTER OF SECTION 34, TOWNSHIP 7 NORTH, RANGE 1 WEST OF THE SALT LAKE BASE AND MERIDIAN. BEGINNING AT A POINT ON THE EAST RIGHT-OF-WAY LINE OF MOUNTAIN ROAD LOCATED SOUTH 89°18'12" EAST 482.67 FEET ALONG THE SOUTH LINE OF THE SAID SOUTHWEST QUARTER AND NORTH 44°05'48" EAST 1118.47 FEET AND SOUTH 45°54'12" EAST 12.62 FEET FROM THE SOUTHWEST CORNER OF THE SAID SOUTHWEST QUARTER; RUNNING THENCE NORTH 37°46'27" EAST 420.98 FEET ALONG THE SAID EAST RIGHT-OF-WAY LINE; THENCE SOUTH 62°19'38" EAST 61.74 FEET; THENCE SOUTH 23°18'21" WEST 444.09 FEET; THENCE NORTH 85°42'46" WEST 49.40 FEET; THENCE NORTH 49°50'38" WEST 131.68 FEET; THENCE NORTH 40°43'13" EAST 20.00 FEET TO THE POINT OF BEGINNING. CONTAINING 1.227 ACRES.

Found Weber County Brass Cap Mon.
West 1/4 Corner Sec. 34, T7N-R1W, S.L.B.&M.

33 34

2615.10'

Section Line (Basis of Bearings)

N 01°12'57" E

Found O.C.S. Monument

33 34 TOWNSHIP 7 NORTH 482.65'
4 3 TOWNSHIP 6 NORTH

Narrative

The purpose of this survey was to Amend the boundary line of Parcel No. 2 from the reconfiguration done 03/24/05 and set the adjusted property corners of parcel 2 as shown and described hereon. The survey was ordered by Jerry Roylance. The control used to establish the property corners was the existing Weber County Survey Monumentation surrounding Section 34, T7N, R1W, S.L.B.&M. The basis of bearing is the West line of the Southwest Corner of said Section said to bear North 00°12'57" East.

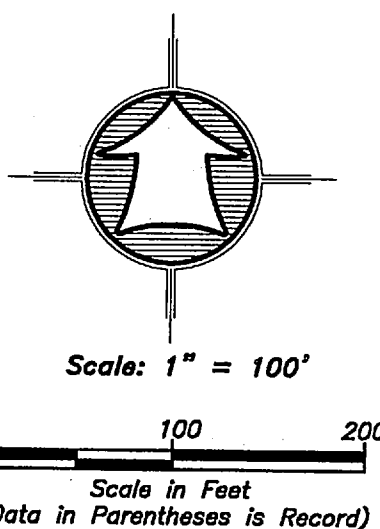

Ophelkens-Randall Farms

Jeffrey Barton

Best View Estates

Parcel 2
Containing 1.227 Acres

Parcel 1
Containing 4.966 Acres

Kenneth Murphey

Kenneth Murphey

Δ = 28°35'36"
R = 160.00'
L = 79.85'
LC = 79.02'
S 8°19'01" W

Δ = 27°04'19"
R = 40.00'
L = 18.90'
LC = 18.72'
S 7°13'03" W

Δ = 12°41'14"
R = 560.00'
L = 124.00'
LC = 123.75'
S 14°25'50" W

Δ = 3°53'08"
R = 950.00'
L = 64.42'
LC = 64.41'
S 10°01'39" W

Δ = 4°29'57"
R = 1050.00'
L = 82.45'
LC = 82.45'
S 9°42'41" W

- LEGEND**
- Subject Property Line
 - Adjoining Property Line
 - Centerline
 - Ditch
 - Fence Line (Wire)
 - Fence Line (wood or Vinyl)
 - Street Monument
 - Found rebar set by others
 - Set 5/8"x24" Rebar With Cap
 - Section Corner

SURVEYOR'S CERTIFICATE

I, K. Greg Hansen, do hereby certify that I am a Registered Professional Land Surveyor in the State of Utah in accordance with Title 53, Chapter 22, Professional Engineers and Land Surveyors Act; and by the Authority of the Owners, I have Completed a Survey of the Property Described and shown Hereon this Plat in accordance with Section 17-23-17 and have Verified all Measurements, and that the same has been Surveyed and Monuments have been Located and/or Placed on the Ground as Represented on the plat Hereon.

Signed this 10 day of NOVEMBER, 2015.

K. Greg Hansen PLS
Utah Land Surveyor License No. 167819

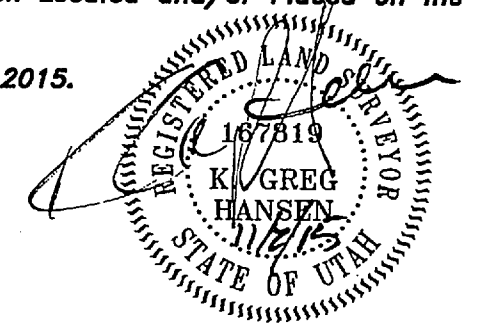

Drawn By: KGH	Date: 10/22/15
Designed By:	
Checked By:	
Approved By:	
Scale: 1"=60'	
Drawing File: 15-3-181v15	
JOB NUMBER: 15-3-181	
Jerry Roylance	
2012 North Mountain Road North Ogden, Utah	
A PART OF THE SOUTHWEST QUARTER OF SECTION 34, TOWNSHIP 7 NORTH, RANGE 1 WEST, S.L.B.& M.	
HANSEN & ASSOCIATES, INC. Consulting Engineers and Land Surveyors	
538 North Main	Brigham City, Utah
Brigham City	Ogden
(435)723-3491	(801)399-4905
(435)752-8272	
Logan	
84302	
No.	By
Date	
Revision	
SHEET 1 OF 1 SHEETS	