

LOT 105
BOUNDARY DESCRIPTION

ALL OF LOT 105, PATIO SPRINGS UNIT NUMBER 1, WEBER COUNTY UTAH, AS SHOWN ON THE OFFICIAL PLAT THEREOF.

SCALE: 1"=20'
DATE: 4/16/15
DESIGN: _____
DRAWN: KHW
CHECKED: KHW

| REVISIONS | DATE | DESCRIPTION |
|-----------|------|-------------|
| | | |
| | | |
| | | |

DWG. - 150401 - WEBC SURVEYING - SPRING BRNCTZENSUNVYVDPAT105.DWG

NARRATIVE:

THE PURPOSE OF THIS SURVEY WAS TO ESTABLISH AND SET THE PROPERTY CORNERS OF THE LOT 105 PATIO SPRINGS SUBDIVISION. THE SURVEY WAS ORDERED BY KELLER WILLIAM REALTY. THE BASIS OF BEARING IS THE CENTERLINE OF CREEKVIEW DRIVE WHICH BEARS NORTH 76°12'53" WEST, WEBER COUNTY, UTAH NORTH, NAD 83, STATE PLANE GRID BEARING. THE PROJECTION OF THE SIDELINES OF LOT 105 WERE SET AT THE INTERSECTION OF THE 30.00 FOOT WIDE PATIO SPRINGS ROADWAY CORRIDOR AND THE INTERSECTION OF THE COMMON AREA AS SHOWN HEREON.

- WEBER COUNTY MONUMENT AS NOTED
- SET 24" REBAR AND CAP MARKED GARDNER ENGINEERING
- PROPERTY LINE
- ADJACENT PARCEL
- SECTION LINE
- EXISTING IRON PIPE FENCE
- EXISTING FENCE

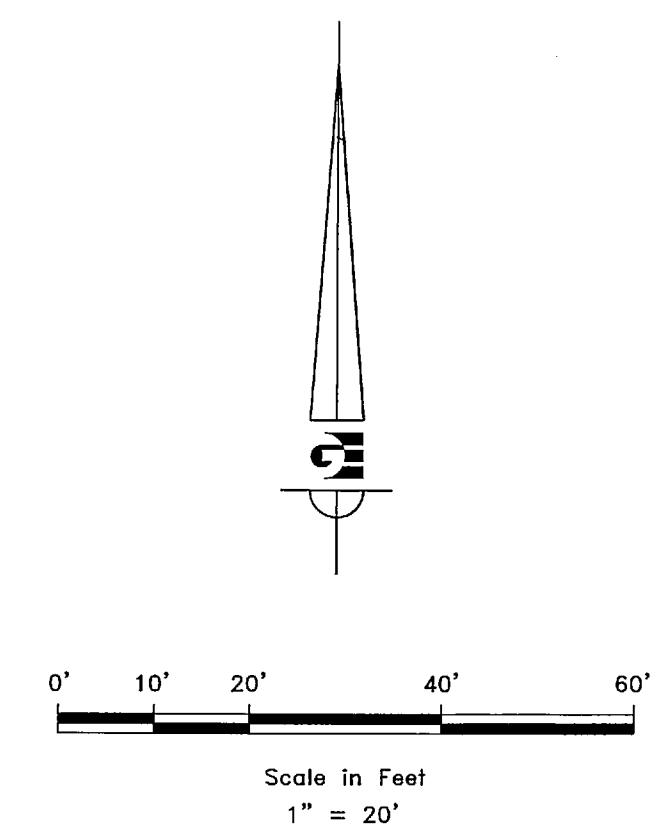

SURVEYOR'S CERTIFICATE

I, KLINT H. WHITNEY, DO HEREBY CERTIFY THAT I AM A LICENSED PROFESSIONAL LAND SURVEYOR IN THE STATE OF UTAH AND THAT I HOLD CERTIFICATE NO. 8227228 IN ACCORDANCE WITH TITLE 58, CHAPTER 22, OF THE PROFESSIONAL ENGINEERS AND LAND SURVEYORS ACT; I FURTHER CERTIFY THAT BY AUTHORITY OF THE OWNERS I HAVE COMPLETED A SURVEY OF THE PROPERTY DESCRIBED ON THIS RECORD OF SURVEY PLAT IN ACCORDANCE WITH SECTION 17-23-17 AND HAVE VERIFIED ALL MEASUREMENTS; THAT THE REFERENCE MONUMENTS SHOWN ON THIS RECORD OF SURVEY PLAT ARE LOCATED AS INDICATED AND ARE SUFFICIENT TO RETRACE OR REESTABLISH THIS SURVEY; AND THAT THE INFORMATION SHOWN HEREIN IS SUFFICIENT TO ACCURATELY ESTABLISH THE LATERAL BOUNDARIES OF THE HEREIN DESCRIBED TRACT OF REAL PROPERTY.

SGINED THIS 3RD DAY OF JUNE, 2016.

RECEIVED
JUL 13 2016
BY: 5500



KLINT H. WHITNEY, PLS NO. 8227228

PROPERTY SURVEY FOR KELLER WILLIAM REALTY
3635 NORTH PATIO SPRINGS ROAD, LOT 105
LOCATED IN THE SOUTHEAST QUARTER OF SECTION 21,
TOWNSHIP 7 NORTH, RANGE 1 EAST, S.L.B. AND M.

GARDNER ENGINEERING
CIVIL, LAND PLANNING
MUNICIPAL, LAND SURVEYING
5150 SOUTH 375 EAST OGDEN, UT
OFFICE: 801.476.0202 FAX: 801.476.0066

S1
1

