

South Quarter Corner of Sec. 16,
T. 7 N., R. 2 W., SLB&M
Found Weber Co. Brass Cap Monument

Southeast Corner of Sec. 16,
T. 7 N., R. 2 W., SLB&M
Found Weber Co. Brass Cap Monument

Narrative
The purpose of this survey was to establish and set the property corners of the parcel as shown and described hereon. The survey was ordered by Shaun Graves. The control used to establish the property corners was the existing Weber County Survey Monumentation surrounding Section 16, T7N, R2W, SLB&M. The basis of bearing is the South line of said Section which bears North 89°52'25" East, Utah North, State Plane, Calculated N.A.D.83 Bearing.

- LEGEND**
- Subject Property Line
 - - - - Adjoining Property Line
 - - - - Previous Property Line
 - +—+ Centerline
 - - - - Ditch
 - - - - Field Separation Line
 - - - - Fence Line (Wire)
 - - - - Fence Line (wood or Vinyl)
 - +—+ Street Monument
 - Found rebar set by others
 - Set 5/8"x24" Rebar With Cap
 - Section Corner

Parcel No. 1
AS SURVEYED BOUNDARY DESCRIPTION
A PART OF THE SOUTHEAST QUARTER OF SECTION 16, TOWNSHIP 7 NORTH, RANGE 2 WEST OF THE SALT LAKE BASE AND MERIDIAN.
BEGINNING AT A POINT ON THE NORTH RIGHT-OF-WAY LINE OF 4000 NORTH STREET LOCATED 682.02 FEET NORTH 89°52'25" EAST ALONG THE SOUTH SECTION LINE OF SAID SECTION 16 AND 16.08 FEET NORTH 00°07'50" WEST FROM THE SOUTH QUARTER CORNER OF SAID SECTION 16;
RUNNING THENCE NORTH 00°07'50" WEST 159.86 FEET (157.84 FEET BY RECORD); THENCE SOUTH 86°19'28" WEST 58.64 FEET; THENCE NORTH 00°07'45" WEST 93.96 FEET; THENCE NORTH 83°14'33" EAST 147.99 FEET (148.08 FEET BY RECORD); THENCE SOUTH 88°56'23" EAST 461.12 FEET; THENCE SOUTH 00°07'35" EAST 266.70 FEET (273.81 FEET BY RECORD) TO THE SAID NORTH RIGHT-OF-WAY; THENCE NORTH 89°11'28" WEST 549.55 FEET ALONG SAID RIGHT-OF-WAY TO THE POINT OF BEGINNING, CONTAINING 3.50 ACRES.

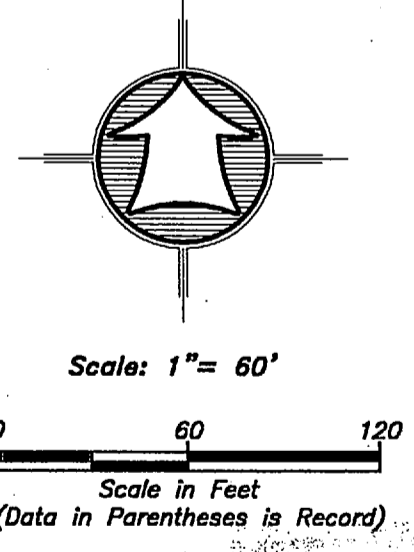

SURVEYOR'S CERTIFICATE
I, K. Greg Hansen, do hereby certify that I am a Registered Professional Land Surveyor in the State of Utah in accordance with Title 56, Chapter 22, Professional Engineers and Land Surveyors Act; and by the Authority of the Owners, I have Completed a Survey of the Property Described and shown Hereon this Plat in accordance with Section 17-23-17 and have Verified all Measurements, and that the same has been Surveyed and Monuments have been Located and/or Placed on the Ground as Represented on the plat Hereon.
Signed this 3rd day of March, 2016.

K. Greg Hansen PLS
Utah Land Surveyor License No. 167819

RECEIVED
AUG 22 2016
BY: 5536

<p>Property Survey for Shaun Graves 3688 West 4000 North Ogden, Weber County, Utah A Part of the Southeast Quarter of Section 16 Township 7 North, Range 2 West, S.L.B.&M.</p>	
<p>Drawn By: RS Designed By: Checked By: Approved By: Scale: 1" = 60' Drawing File: 16-3-64x15 JOB NUMBER: 16-3-64</p>	<p>Date: 4/19/16</p>
<p> HANSEN & ASSOCIATES, INC. Consulting Engineers and Land Surveyors 538 North Main Street, Brigham, Utah 84302 Visit Us at www.hais.net Ogden, Utah (435) 723-3481 (801) 389-4905 (435) 752-8272 </p>	
<p>Sheet 1 of 1 Sheets</p>	<p>No. Date By Revision</p>