

Center of Sec. 13,
T. 7 N., R. 2 E., SLB&M
Found Wayne Crow Rebar
Per Record of Survey 3378.

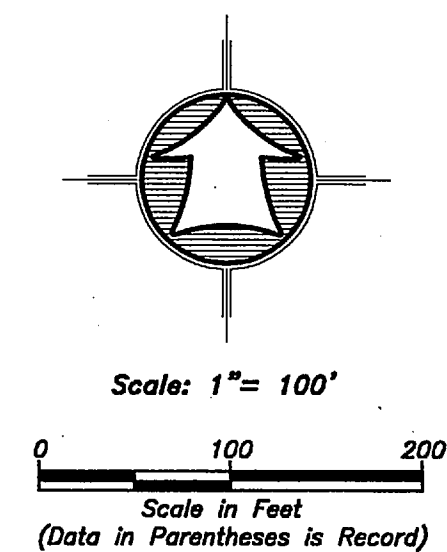

LEGEND

—	Subject Property Line
- - -	Adjoining Property Line
- - -	Previous Property Line
—	Centerline
- - -	Gravel Road
- - -	Field Separation Line
- - -	Fence Line (Wire)
⊙	Street Monument
⊙	Found rebar set by others
⊙	Set 5/8"x24" Rebar With Cap
⊙	Section Corner

Narrative

The purpose of this survey was to establish and set the property corners of the parcel as shown and described hereon. The survey was ordered by Carson Jones of Blackburn Jones. The control used to establish the property corners was the existing GLO Sectional Survey Monumentation surrounding Section 13, 75N, R2E, SLB&M. The basis of bearing is the West line of said Section which bears North 0°27'16" East, Utah North, State Plane, Calculated N.A.D.83 Bearing.

AS RECORDED DESCRIPTION

PART OF THE SOUTHEAST QUARTER OF THE NORTHEAST QUARTER OF SECTION 13, TOWNSHIP 7 NORTH, RANGE 2 EAST, SALT LAKE BASE & MERIDIAN: BEGINNING AT A POINT SOUTH 89°09'40" WEST 877.86 FEET FROM THE EAST QUARTER CORNER OF SECTION 13, RUNNING THENCE SOUTH 89°09'40" WEST 442.14 FEET; THENCE NORTH 02°23' EAST 1320 FEET; THENCE NORTH 89°09'40" EAST 1320 FEET; THENCE SOUTH 02°23' WEST 405.75 FEET; THENCE SOUTH 46°47'10" WEST 679.13 FEET; THENCE ALONG A 346.91 FOOT RADIUS CURVE TO THE LEFT 90.79 FEET (LC = SOUTH 39°17'18" WEST 9.53 FEET); THENCE SOUTH 31°47'27" WEST 186.87 FEET; THENCE ALONG A 393.58 FOOT RADIUS CURVE TO THE RIGHT 108.46 FEET (LC = SOUTH 39°04'08" WEST 108.12 FEET); THENCE SOUTH 47°04'49" WEST 222.23 FEET TO THE POINT OF BEGINNING. (LOT 17, SUNRIDGE RANCHES, NO. 1, AN UNRECORDED SUBDIVISION).

(C1)	(C2)
Δ = 14°59'43"	Δ = 15°47'22"
R = 346.91'	R = 393.58'
L = 90.79'	L = 108.46'
LC = 90.53'	LC = 108.12'
S 39°23'40" W	S 39°47'30" W

RECEIVED
JAN 05 2017
BY: 5642

SURVEYOR'S CERTIFICATE

I, K. Greg Hansen, do hereby certify that I am a Registered Professional Land Surveyor in the State of Utah in accordance with Title 58, Chapter 22, Professional Engineers and Land Surveyors Act; and by the Authority of the Owners, I have completed a Survey of the Property Described and shown hereon this Plat in accordance with Section 17-23-17 and have verified all measurements, and that the same has been surveyed and monuments have been located and/or placed on the ground as represented on the plat hereon.

Signed this 17th day of Sept, 2016.

K. Greg Hansen PLS
Utah Land Surveyor License No. 167819

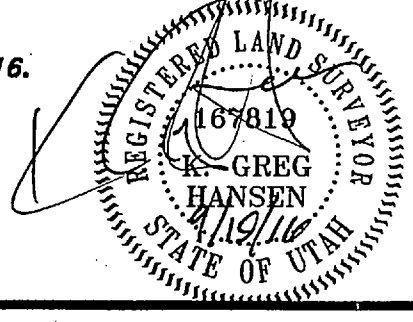

<p>Property Survey for Carson Jones Weber County, Utah A Part of the Northeast Quarter of Section 13, Township 7 North, Range 2 East, S.L.B.&M.</p>	
<p>Drawn By: <u>lgjh</u> Date: <u>XXXX</u> Designed By: Checked By: Approved By: Scale: 1" = 100' Drawing File: <u>16-3-131v15</u> JOB NUMBER: <u>16-3-131</u></p>	<p>HANSEN & ASSOCIATES, INC. Consulting Engineers and Land Surveyors 536 North Main Street, Brigham, Utah 84302 Brigham, UT, USA (435) 725-4491 (801) 369-4805 (435) 752-8272 www.hanseninc.com</p>
<p>Sheets 1 of 1 Sheets</p>	<p>No. _____ Date _____ By _____ Revision _____</p>