

**PARCEL A
BOUNDARY DESCRIPTION**

A PART OF THE NORTHEAST QUARTER OF SECTION 17, TOWNSHIP 5 NORTH, RANGE 1 WEST, OF THE SALT LAKE BASE AND MERIDIAN. BEGINNING AT A POINT BEING LOCATED NORTH 00°52'40" EAST 629.50 FEET ALONG THE EAST LINE OF SAID NORTHEAST QUARTER AND NORTH 90°00'00" WEST 260.63 FEET FROM THE SOUTHEAST CORNER OF SAID NORTHEAST QUARTER; RUNNING THENCE ALONG AN AGREED UPON BOUNDARY LINE AS RECORDED IN ENTRY 1066464 OF THE WEBER COUNTY RECORDS THE FOLLOWING TWO (2) COURSES: (1) SOUTH 10°34'05" WEST 104.80 FEET; (2) SOUTH 39°59'28" WEST 125.51 FEET; THENCE ALONG THE ARC OF A 97.50 FOOT RADIUS CURVE TO THE LEFT 58.33 FEET, HAVING A CENTRAL ANGLE OF 34°34'25"; CHORD BEARS NORTH 68°46'18" WEST 57.95 FEET; THENCE NORTH 86°03'34" WEST 6.10 FEET TO THE EAST RIGHT-OF-WAY LINE OF 375 EAST STREET; THENCE ALONG SAID EAST RIGHT-OF-WAY LINE THE FOLLOWING FOUR (4) COURSES: (1) ALONG THE ARC OF A 280.00 FOOT RADIUS CURVE TO THE LEFT 48.77 FEET, HAVING A CENTRAL ANGLE OF 09°58'48"; CHORD BEARS NORTH 03°19'14" WEST 48.71 FEET; (2) NORTH 08°18'37" WEST 81.37 FEET; (3) ALONG THE ARC OF A 201.50 FOOT RADIUS CURVE TO THE RIGHT 109.06 FEET, HAVING A CENTRAL ANGLE OF 31°00'39"; CHORD BEARS NORTH 07°11'42" EAST 107.73 FEET; (4) ALONG THE ARC OF A 280.00 FOOT RADIUS CURVE TO THE LEFT 115.88 FEET, HAVING A CENTRAL ANGLE OF 23°42'42"; CHORD BEARS NORTH 10°50'44" EAST 115.05 FEET; THENCE ALONG THE ARC OF A 2696.64 FOOT RADIUS NON-TANGENT CURVE TO THE LEFT 41.39 FEET, HAVING A CENTRAL ANGLE OF 00°52'48"; CHORD BEARS SOUTH 38°48'25" EAST 41.39 FEET; THENCE NORTH 77°02'07" EAST 55.89 FEET TO THE WESTERLY RIGHT-OF-WAY LINE OF WASHINGTON BOULEVARD; THENCE ALONG SAID WESTERLY RIGHT-OF-WAY LINE SOUTH 44°47'00" WEST 50.04 FEET; THENCE ALONG THE ARC OF A 2696.64 FOOT RADIUS CURVE TO THE LEFT 17.98 FEET, HAVING A CENTRAL ANGLE OF 00°22'55"; CHORD BEARS SOUTH 43°03'26" EAST 17.98 FEET TO THE POINT OF BEGINNING. CONTAINING 1.124 ACRES.

NARRATIVE:

THE PURPOSE OF THE SURVEY WAS TO DO AN AGRICULTURAL DIVISION OF THE PARCELS AS SHOWN AND DESCRIBED HEREON. NO DEVELOPMENT CAN OCCUR ON PARCELS A&B UNTIL THE INDIVIDUAL PARCEL GOES THROUGH THE PROPER SUBDIVISION PROCESS AND GETS APPROVAL FROM THE GOVERNING MUNICIPALITY. THE SURVEY WAS ORDERED BY CHUCK HEWARD. THE CONTROL USED TO ESTABLISH THE BOUNDARY WAS THE EXISTING WEBER COUNTY SURVEY MONUMENTATION AS SHOWN AND NOTED HEREON. THE BASIS OF BEARING IS THE EAST LINE OF THE SOUTHEAST QUARTER OF SECTION 27, TOWNSHIP 7 NORTH, RANGE 1 EAST, OF THE SALT LAKE BASE AND MERIDIAN WHICH BEARS SOUTH 0°22'02" WEST WEBER COUNTY GRID BEARING.

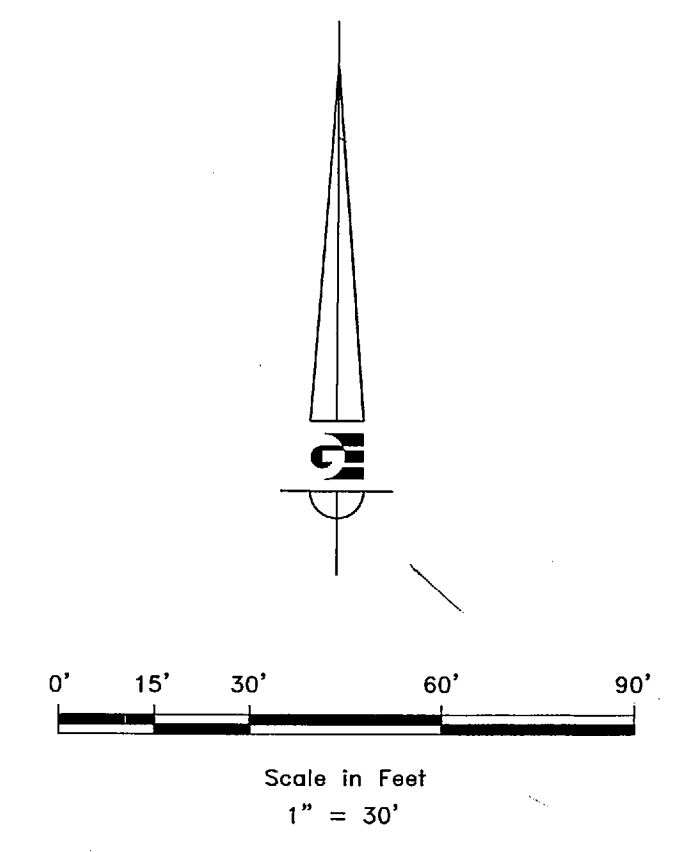

SURVEYOR'S CERTIFICATE

I, KLINT H. WHITNEY, DO HEREBY CERTIFY THAT I AM A LICENSED PROFESSIONAL LAND SURVEYOR IN THE STATE OF UTAH AND THAT I HOLD CERTIFICATE NO. 8227228 IN ACCORDANCE WITH TITLE 58, CHAPTER 22, OF THE PROFESSIONAL ENGINEERS AND LAND SURVEYORS ACT; I FURTHER CERTIFY THAT BY AUTHORITY OF THE OWNERS I HAVE COMPLETED A SURVEY OF THE PROPERTY DESCRIBED ON THIS RECORD OF SURVEY PLAT IN ACCORDANCE WITH SECTION 17-23-17 AND HAVE VERIFIED ALL MEASUREMENTS; THAT THE REFERENCE MONUMENTS SHOWN ON THIS RECORD OF SURVEY PLAT ARE LOCATED AS INDICATED AND ARE SUFFICIENT TO RETRACE OR REESTABLISH THIS SURVEY; AND THAT THE INFORMATION SHOWN HEREIN IS SUFFICIENT TO ACCURATELY ESTABLISH THE LATERAL BOUNDARIES OF THE HEREIN DESCRIBED TRACT OF REAL PROPERTY.

SIGNED THIS 17TH DAY OF JUNE, 2016.

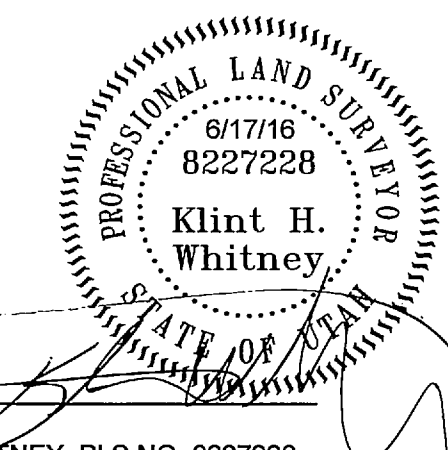

RECEIVED
JAN 24 2017
BY: 5654

KLINT H. WHITNEY, PLS NO. 8227228

REVISIONS	DATE	DESCRIPTION

PROPERTY SURVEY FOR GARDNER ENGINEERING
5150 SOUTH 375 EAST, WASHINGTON TERRACE, UT
LOCATED IN THE NORTHEAST QUARTER OF SECTION 17,
TOWNSHIP 5 NORTH, RANGE 1 WEST, S.L.B. AND M.

GARDNER ENGINEERING
CIVIL, LAND PLANNING
MUNICIPAL, LAND SURVEYING
5150 SOUTH 375 EAST OGDEN, UT
OFFICE: 801.476.0202 FAX: 801.476.0066

S1
1

- WEBER COUNTY MONUMENT AS NOTED
- SET 24" REBAR AND CAP MARKED GARDNER ENGINEERING
- PROPERTY LINE
- ADJACENT PARCEL
- SECTION LINE
- EXISTING IRON PIPE FENCE
- EXISTING FENCE