

**PARCEL 14-003-0025
BOUNDARY DESCRIPTION**

ALL OF LOTS 13 AND 14 AND THE NORTH 8 FEET OF LOT 12, BLOCK 3, VALLEY VIEW ADDITION TO OGDEN CITY, WEBER COUNTY, UTAH, CONTAINING 0.177 ACRES.

**PARCEL 14-003-0005
BOUNDARY DESCRIPTION**

ALL OF LOTS 15 AND 16 AND THE NORTH 8 FEET OF LOT 17, BLOCK 3, VALLEY VIEW ADDITION TO OGDEN CITY, WEBER COUNTY, UTAH, CONTAINING 0.178 ACRES.

NARRATIVE:

THE PURPOSE OF THIS SURVEY WAS TO ESTABLISH AND SET THE PROPERTY CORNERS OF THE PARCELS AS SHOWN AND DESCRIBED HEREON. THE CONTROL USED TO ESTABLISH THE PROPERTY CORNERS WAS THE EXISTING OGDEN CITY SURVEY MONUMENTATION AND FOUND REBAR FROM RECORDED SURVEY ON ADJOINING PARCELS. THE BASIS OF BEARING IS THE MONUMENTED CENTERLINE OF 19TH STREET BETWEEN JACKSON AVENUE AND ECCLES AVENUE WHICH BEARS SOUTH 88°40'00" EAST WEBER COUNTY, UTAH NORTH, NAD 83, STATE PLANE GRID BEARING.

- OGDEN CITY MONUMENT AS NOTED
- SET 24" REBAR AND CAP MARKED GARDNER ENGINEERING
- FOUND REEVES REBAR CAP
- PROPERTY LINE
- ADJACENT PARCEL
- SECTION LINE
- EXISTING IRON PIPE FENCE
- EXISTING FENCE

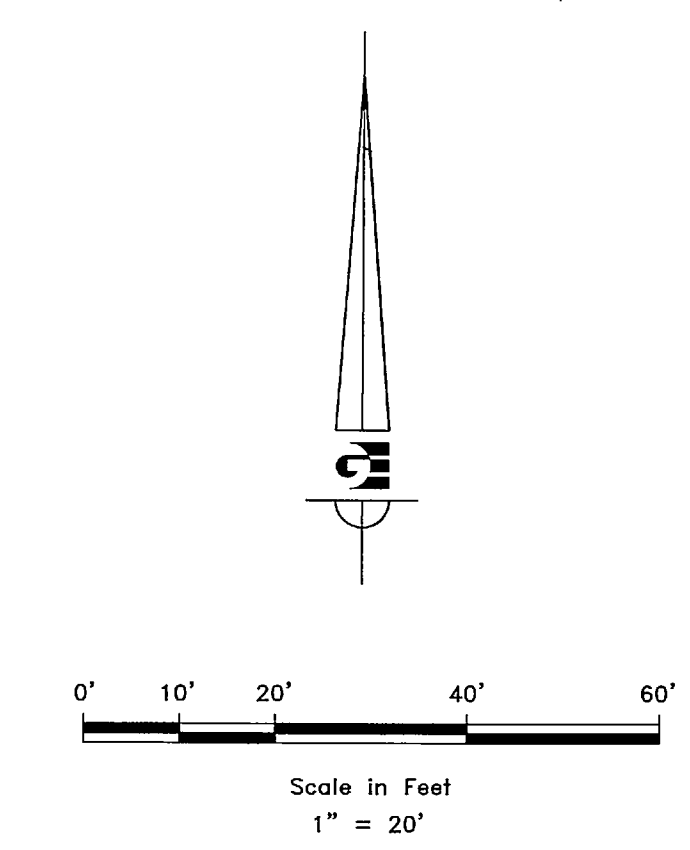

SURVEYOR'S CERTIFICATE

I, KLINT H. WHITNEY, DO HEREBY CERTIFY THAT I AM A LICENSED PROFESSIONAL LAND SURVEYOR IN THE STATE OF UTAH AND THAT I HOLD CERTIFICATE NO. 8227228 IN ACCORDANCE WITH TITLE 58, CHAPTER 22, OF THE PROFESSIONAL ENGINEERS AND LAND SURVEYORS ACT; I FURTHER CERTIFY THAT BY AUTHORITY OF THE OWNERS I HAVE COMPLETED A SURVEY OF THE PROPERTY DESCRIBED ON THIS RECORD OF SURVEY PLAT IN ACCORDANCE WITH SECTION 17-23-17 AND HAVE VERIFIED ALL MEASUREMENTS; THAT THE REFERENCE MONUMENTS SHOWN ON THIS RECORD OF SURVEY PLAT ARE LOCATED AS INDICATED AND ARE SUFFICIENT TO RETRACE OR REESTABLISH THIS SURVEY; AND THAT THE INFORMATION SHOWN HEREIN IS SUFFICIENT TO ACCURATELY ESTABLISH THE LATERAL BOUNDARIES OF THE HEREIN DESCRIBED TRACT OF REAL PROPERTY.

SIGNED THIS 16TH DAY OF DECEMBER, 2016.

RECEIVED
FEB 27 2017
BY: 5615

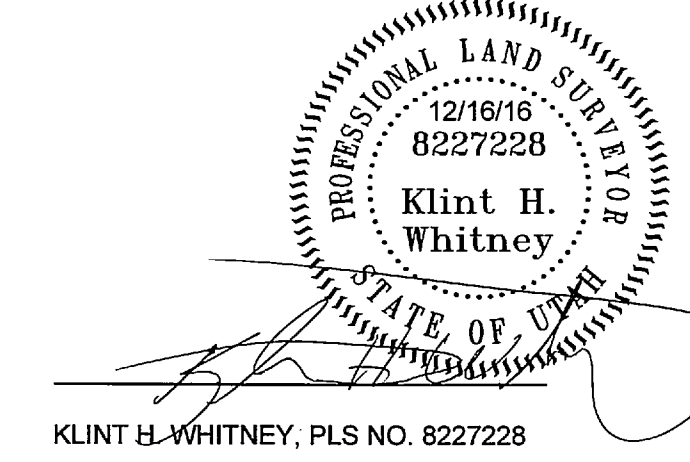

SCALE: 1"=20'	DATE: 12/16/16
DESIGN: _____	DRAWN: KHW
REVISIONS	CHECKED: KHW
DESCRIPTION	
DATE	

DATE	DESCRIPTION

PROPERTY SURVEY FOR DAVID GILL
1825 ECCLES AND 1826 JEFFERSON, OGDEN, UTAH
LOCATED IN THE NORTHEAST QUARTER OF SECTION 28,
TOWNSHIP 6 NORTH, RANGE 1 WEST, S.L.B. AND M.

GARDNER ENGINEERING
CIVIL-LAND PLANNING
MUNICIPAL-LAND SURVEYING
5150 SOUTH 375 EAST OGDEN, UT
OFFICE: 801-476-0202 FAX: 801-476-0066

S1
1