

PARCEL 061620005 RECORD
BOUNDARY DESCRIPTION

ALL OF LOT 5, TURF PARK SUBDIVISION NO. 1, RIVERDALE CITY, WEBER COUNTY, UTAH.

PARCEL 060160099 RECORD
BOUNDARY DESCRIPTION

PART OF THE SOUTHWEST QUARTER OF SECTION 7, TOWNSHIP 5 NORTH, RANGE 1 WEST, SALT LAKE BASE & MERIDIAN, U.S. SURVEY: BEGINNING AT THE SOUTHWEST CORNER OF LOT 5, TURF PARK SUBDIVISION NO. 1, RIVERDALE CITY, UTAH; SAID POINT IS ALSO GIVEN AS BEGINNING AT A POINT ON AN EXISTING FENCE LINE 2034.38 FEET EAST AND 249.05 FEET SOUTH 2D04'07" WEST FROM THE SOUTHWEST CORNER OF SAID SECTION 7; RUNNING THENCE SOUTH 88°28' EAST 78.91 FEET ALONG THE SOUTH BOUNDARY OF SAID SUBDIVISION; THENCE SOUTH 1D34' WEST 87.99 FEET; THENCE NORTH 88°28' WEST 80.04 FEET; THENCE NORTH 2D18' EAST 88.00 FEET TO THE POINT OF BEGINNING.

AS SURVEYED COMBINED
BOUNDARY DESCRIPTION

A PART OF THE SOUTHWEST QUARTER OF SECTION 7, TOWNSHIP 5 NORTH, RANGE 1 WEST, OF THE SALT LAKE BASE AND MERIDIAN. BEGINNING AT A POINT ON THE SOUTH RIGHT-OF-WAY LINE OF 4375 SOUTH STREET BEING LOCATED SOUTH 00°47'56" WEST 60.70 FEET ALONG THE WEST LINE OF SAID SOUTHWEST QUARTER AND NORTH 90°00'00" EAST 1821.79 FEET FROM THE NORTHWEST CORNER OF SAID SOUTHWEST QUARTER; RUNNING THENCE ALONG SAID SOUTH RIGHT-OF-WAY LINE SOUTH 87°52'40" EAST 77.50 FEET; THENCE SOUTH 02°07'20" WEST 110.00 FEET TO AN EXISTING FENCE LINE; THENCE ALONG SAID EXISTING FENCE LINE THE FOLLOWING THREE (3) COURSES: (1) SOUTH 03°16'14" WEST 92.01 FEET; (2) NORTH 84°57'00" WEST 78.29 FEET; (3) NORTH 02°51'16" EAST 88.00 FEET; THENCE NORTH 02°51'20" EAST 110.01 FEET TO THE POINT OF BEGINNING. CONTAINING 15,674 SQ. FT.

OWNER'S AFFIDAVIT

I, THE UNDERSIGNED OWNER(S) OF THE HEREON DESCRIBED TRACT OF LAND, HAVING CAUSED THE SAME TO BE COMBINED INTO ONE PARCEL IN RIVERDALE CITY.

SIGNED THIS 5th DAY OF April, 2017.

BY: *Ken Griffiths*

RIVERDALE CITY REVIEW STATEMENT

THIS IS TO CERTIFY THAT THIS BOUNDARY COMBINATION PLAT WAS REVIEWED BY RIVERDALE CITY ON THIS 5th DAY OF April, 2017.

SIGNED: *Michael Eggert* NAME/TITLE: *Michael Eggert, Community Development Director*

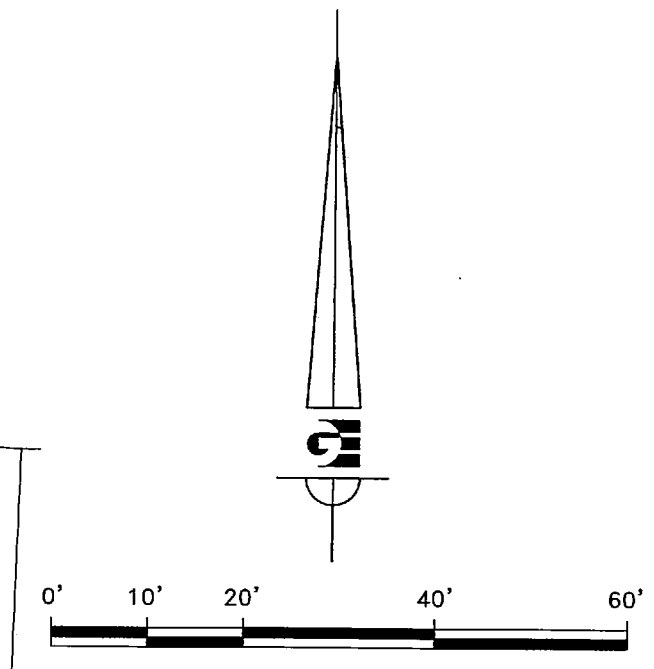

- LEGEND**
- ◆ WEBER COUNTY MONUMENT AS NOTED
 - SET 24" REBAR AND CAP MARKED GARDNER ENGINEERING
 - SUBDIVISION BOUNDARY
 - LOT LINE
 - - - ADJACENT PARCEL
 - - - SECTION LINE
 - - - EASEMENT
 - × EXISTING FENCE LINE

NARRATIVE

THE PURPOSE OF THE SURVEY WAS TO COMBINE THE EXISTING WEBER COUNTY TAX PARCELS 060160099 AND 061620005 INTO ONE PARCEL. THE SURVEY WAS ORDERED BY KEN GRIFFITHS. THE BASIS OF BEARING IS THE WEST LINE OF THE SOUTHWEST QUARTER OF SECTION 7, TOWNSHIP 5 NORTH, RANGE 1 WEST OF THE SALT LAKE BASE AND MERIDIAN WHICH BEARS NORTH 00°47'56" EAST, WEBER COUNTY, UTAH NORTH, NAD 83 STATE PLANE GRID BEARING.

SURVEYOR'S CERTIFICATE

I, KLINT H. WHITNEY, DO HEREBY CERTIFY THAT I AM A LICENSED PROFESSIONAL LAND SURVEYOR IN THE STATE OF UTAH AND THAT I HOLD CERTIFICATE NO. 8227228 IN ACCORDANCE WITH TITLE 58, CHAPTER 22, OF THE PROFESSIONAL ENGINEERS AND LAND SURVEYORS ACT; I FURTHER CERTIFY THAT BY AUTHORITY OF THE OWNERS I HAVE COMPLETED A SURVEY OF THE PROPERTY DESCRIBED ON THIS RECORD OF SURVEY PLAT IN ACCORDANCE WITH SECTION 17-23-20 AND HAVE VERIFIED ALL MEASUREMENTS; THAT THE REFERENCE MONUMENTS SHOWN ON THIS RECORD OF SURVEY PLAT ARE LOCATED AS INDICATED AND ARE SUFFICIENT TO RETRACE OR REESTABLISH THIS SURVEY; AND THAT THE INFORMATION SHOWN HEREIN IS SUFFICIENT TO ACCURATELY ESTABLISH THE LATERAL BOUNDARIES OF THE HEREIN DESCRIBED TRACT OF REAL PROPERTY.

SIGNED THIS 3rd DAY OF APRIL, 2017.

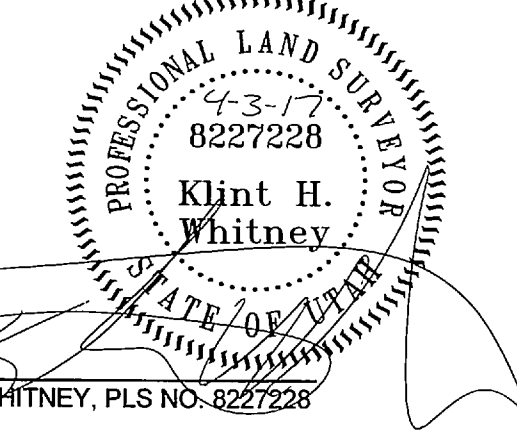

RECEIVED
APR 05 2017
BY: 5105

KLINT H. WHITNEY, PLS NO. 8227228

REVISIONS	DATE	DESCRIPTION

BOUNDARY COMBINATION SURVEY FOR KENNETH GRIFFITHS
 839 WEST 4375 SOUTH, RIVERDALE UTAH
 LOCATED IN THE SOUTHWEST QUARTER OF SECTION 7,
 TOWNSHIP 5 NORTH, RANGE 1 WEST, S.L.B. AND M.

GARDNER ENGINEERING
 CIVIL - LAND PLANNING
 MUNICIPAL - LAND SURVEYING
 5150 SOUTH 375 EAST OGDEN, UT
 OFFICE: 801.476.0202 FAX: 801.476.0066

S1
 1

