

LEGEND

- Subject Property Line
- Adjoining Property Line
- Previous Property Line
- Centerline
- Ditch
- Field Separation Line
- Fence Line (Wire)
- Fence Line (wood or Vinyl)
- Street Monument
- Found rebar set by others
- Set 5/8"x24" Rebar With Cap
- Section Corner
- Calculated Section Corner

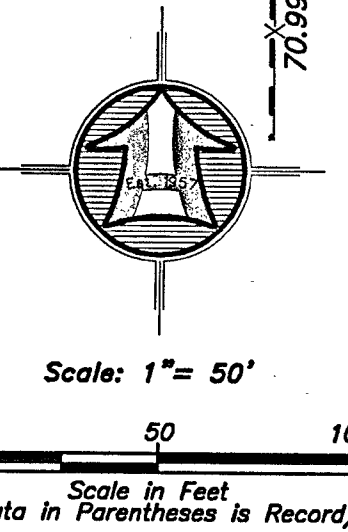

Boundary Description

Lot 16, Bailey Subdivision, North Ogden, Weber County Survey located in the West half of Section 29, Township 7 North, Range 1 West of the Salt Lake Base and Meridian.

Narrative

The purpose of this survey was to establish and set the property corners of the parcel as shown and described hereon. The survey was ordered by Dave Boatwright. The control used to establish the property corners was the existing found rebar and occupation lines within the Bailey Subdivision. No street monuments were found along 150 West. Brass cap monuments were found on Elberta Drive at 175 West and 300 East. The basis of bearing is the line established by these monuments assumed to bear S 60°16'40" E.

SURVEYOR'S CERTIFICATE

I, K. Greg Hansen, do hereby certify that I am a Registered Professional Land Surveyor in the State of Utah in accordance with Title 58, Chapter 22, Professional Engineers and Land Surveyors Act; and by the authority of the owners, I have completed a survey of the property described and shown hereon this plat in accordance with Section 17-23-17 and have verified all measurements, and that the same has been surveyed and monuments have been located and/or placed on the ground as represented on the plat hereon.

Signed this 5th day of July, 2017.

K. Greg Hansen PLS
Utah Land Surveyor Licence No. 167819

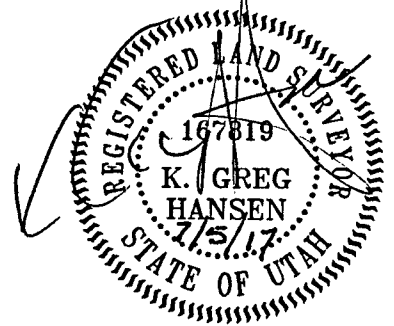

RECEIVED
BY: 5813

HANSEN & ASSOCIATES, INC. Consulting Engineers and Land Surveyors 538 North Main Street, Brigham, Utah 84302 Visit us at www.hansen.net Brigham City Ogden Logan (435) 723-3491 (801) 359-4905 (435) 722-8272 Celebrating 60 Years of Business	
Drawn By: kgh Date: 06/15/17	Designed By: _____
Checked By: _____	Approved By: _____
Scale: 1" = 50'	Drawing File: 17-3-121ps
JOB NUMBER: 17-3-121	
Property Survey for David Boatwright 2974 North 150 West North Ogden City, Weber County, Utah A Part of the West Half of Section 29, T 7 N., R 1 W., S.L.B.&M.	
Sheet 1	Of 1 Sheets
No.	Date
By	Revision