

**BOUNDARY DESCRIPTION**  
 ALL OF LOT 44, ELKHORN SUBDIVISION PHASE 3, WEBER COUNTY, UTAH, ACCORDING TO THE OFFICIAL PLAT THEREOF.

**WEBER COUNTY RE-15 ZONING INFORMATION**

**Zone RE-15**  
 Minimum lot area  
 Uses listed in 3-2 & 3-5 15,000 ft<sup>2</sup>  
 Uses listed in 3-3 40,000 ft<sup>2</sup>  
 Uses listed in 3-4 5 acres  
 Minimum lot width 100 ft  
 Minimum yard setbacks  
 a. Front 30 ft  
 b. Side  
 i. Dwelling 10 ft[1]  
 ii. Other main building 20 ft each side  
 iii. Accessory building 10 ft[2]  
 iv. Accessory building > 1,000 ft<sup>2</sup> [3]  
 c. Side (facing street on corner lot) 20 ft  
 d. Rear  
 i. Main building 30 ft  
 ii. Accessory building 1 ft[4]  
 Main building height  
 a. Minimum one story  
 b. Maximum 35 ft  
 Accessory building height 25 ft[5]

**Notes:**  
 † 1.0 1.1 10 ft with total width of two side yards not less than 24 ft.  
 † 2.0 2.1 10 ft except one foot if located at least 6 ft in rear of main building.  
 † 3.0 3.1 For storage of personal equipment and materials see chapter 23-29.  
 † 4.0 4.1 1 foot except 10 feet where accessory building rears on side yard of adjacent corner lot.  
 † 5.0 5.1 25 ft unless meeting requirements of Chapter 23-29, Large Accessory Buildings.

**LEGEND**

- ◆ WEBER COUNTY MONUMENT AS NOTED
- PROPERTY CORNER AS NOTED
- SUBDIVISION BOUNDARY
- LOT LINE
- ADJACENT PARCEL
- SECTION LINE
- EASEMENT
- SETBACK LINE
- EXISTING FENCE LINE
- EXISTING 1' CONTOUR
- EXISTING 5' CONTOUR
- EXISTING SEWER LINE
- EXISTING WATER LINE
- EXISTING SECONDARY WATER LINE
- EXISTING COMMUNICATIONS LINE
- ☐ TELEPHONE PEDISTAL
- ☐ FIRE HYDRANT
- ☐ WATER VALVE
- ☐ WATER METER
- ☐ SEWER MAN HOLE
- ☐ IRRIGATION VALVE BOX
- ☐ EXISTING PINE TREE

**NARRATIVE**

THE PURPOSE OF THIS SURVEY WAS TO DO A TOPOGRAPHIC AND BOUNDARY SURVEY OF THE PARCEL AS SHOWN AND DESCRIBED HEREON. THE SURVEY WAS ORDERED BY KEVIN HILL. THE BASIS OF BEARING IS THE CENTERLINE OF BUCKHORN DRIVE BETWEEN THE FOUND CENTERLINE MONUMENTS NOTED HEREON WHICH BEARS NORTH 24°26'31" WEST WEBER COUNTY, UTAH NORTH, NAD 83 STATE PLANE GRID BEARING. BEARINGS FROM THE DEDICATED PLAT HAVE BEEN ROTATED TO THE FOUND CENTERLINE MONUMENTS AND ORIGINAL REBAR AS NOTED HEREON. VERTICAL DATUM IS NAVD 88.

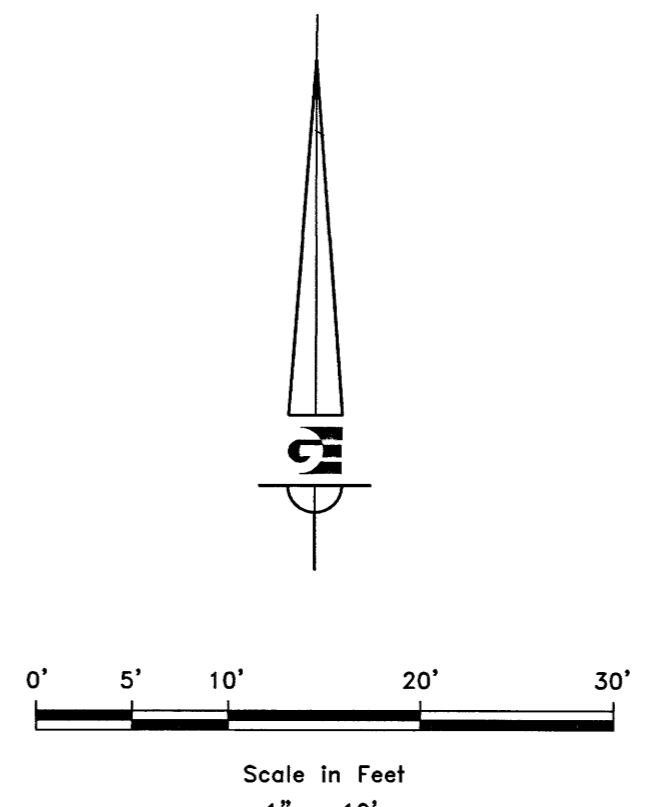

**SURVEYOR'S CERTIFICATE**

I, KLINT H. WHITNEY, DO HEREBY CERTIFY THAT I AM A LICENSED PROFESSIONAL LAND SURVEYOR IN THE STATE OF UTAH AND THAT I HOLD CERTIFICATE NO. 8227228 IN ACCORDANCE WITH TITLE 58, CHAPTER 22, OF THE PROFESSIONAL ENGINEERS AND LAND SURVEYORS ACT; I FURTHER CERTIFY THAT BY AUTHORITY OF THE OWNERS I HAVE COMPLETED A SURVEY OF THE PROPERTY DESCRIBED ON THIS RECORD OF SURVEY PLAT IN ACCORDANCE WITH SECTION 17-23-20 AND HAVE VERIFIED ALL MEASUREMENTS; THAT THE REFERENCE MONUMENTS SHOWN ON THIS RECORD OF SURVEY PLAT ARE LOCATED AS INDICATED AND ARE SUFFICIENT TO RETRACE OR REESTABLISH THIS SURVEY; AND THAT THE INFORMATION SHOWN HEREIN IS SUFFICIENT TO ACCURATELY ESTABLISH THE LATERAL BOUNDARIES OF THE HEREIN DESCRIBED TRACT OF REAL PROPERTY.

SIGNED THIS 12<sup>TH</sup> DAY OF December 2017.



SCALE: 1" = 10'
DATE: 11/14/17
DESIGN: _____
DRAWN: KHW
CHECKED: KHW

REVISIONS	DESCRIPTION
DATE	

RECEIVED  
 DEC 13 2017  
 BY: 5883

PROPERTY SURVEY FOR KEVIN HILL  
 5519 EAST BUCKHORN DRIVE  
 LOCATED IN THE NW 1/4 SEC. 26 AND THE NE 1/4 SEC. 27  
 TOWNSHIP 7 NORTH, RANGE 1 EAST, S.L.B. AND M.

**GARDNER ENGINEERING**  
 CIVIL - LAND PLANNING  
 MUNICIPAL - LAND SURVEYING  
 5150 SOUTH 875 EAST COGDEN UT  
 OFFICE: 801-476-0212 FAX: 801-476-0066

S1  
 1