

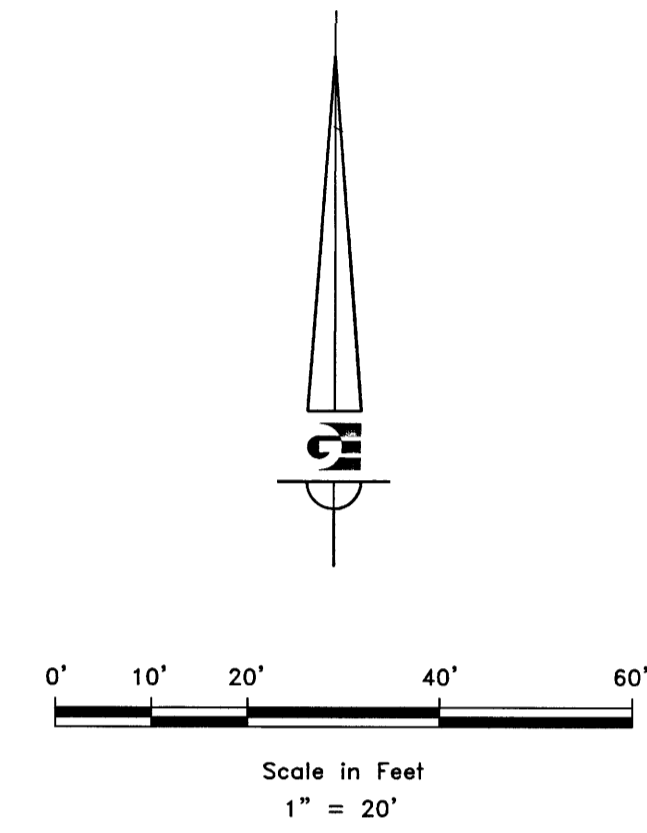

**BOUNDARY DESCRIPTION**  
ALL OF LOT 278, CANTERBURY CROSSING PHASE 2 SUBDIVISION.



- LEGEND**
- WEBER COUNTY CENTERLINE MONUMENT
  - SET 24" REBAR AND CAP MARKED GARDNER ENGINEERING
  - LOT LINE
  - CENTERLINE
  - ADJACENT PARCEL
  - SECTION LINE
  - SECTION TIE
  - EXISTING FENCE LINE

**NARRATIVE**

THE PURPOSE OF THE SURVEY WAS TO ESTABLISH THE BOUNDARY OF PARCEL NO. 084520038 AS SHOWN AND DESCRIBED HEREON. THE SURVEY WAS ORDERED BY CONSTANCE TAYLOR. THE CONTROL USED TO ESTABLISH THE BOUNDARY WAS THE EXISTING WEBER COUNTY SURVEY MONUMENTATION AS SHOWN AND NOTED HEREON. VESTING DEED #2863271 AND CANTERBURY CROSSING PHASE 2 PLAT RECORDED AS ENTRY NO. 2133523. THE BASIS OF BEARING IS THE CENTERLINE OF 4350 SOUTH STREET SECTION 10, TOWNSHIP 5 NORTH, RANGE 2 WEST, OF THE SALT LAKE BASE AND MERIDIAN WHICH BEARS NORTH 69°16'32" WEST WEBER COUNTY, UTAH NORTH, NAD 83 STATE PLANE GRID BEARING.

**SURVEYOR'S CERTIFICATE**

I, KLINT H. WHITNEY, DO HEREBY CERTIFY THAT I AM A LICENSED PROFESSIONAL LAND SURVEYOR IN THE STATE OF UTAH AND THAT I HOLD CERTIFICATE NO. 8227228 IN ACCORDANCE WITH TITLE 58, CHAPTER 22, OF THE PROFESSIONAL ENGINEERS AND LAND SURVEYORS ACT; I FURTHER CERTIFY THAT BY AUTHORITY OF THE OWNERS I HAVE COMPLETED A SURVEY OF THE PROPERTY DESCRIBED ON THIS RECORD OF SURVEY PLAT IN ACCORDANCE WITH SECTION 17-23-20 AND HAVE VERIFIED ALL MEASUREMENTS; THAT THE REFERENCE MONUMENTS SHOWN ON THIS RECORD OF SURVEY PLAT ARE LOCATED AS INDICATED AND ARE SUFFICIENT TO RETRACE OR REESTABLISH THIS SURVEY; AND THAT THE INFORMATION SHOWN HEREIN IS SUFFICIENT TO ACCURATELY ESTABLISH THE LATERAL BOUNDARIES OF THE HEREIN DESCRIBED TRACT OF REAL PROPERTY.

SIGNED THIS 13<sup>TH</sup> DAY OF December, 2017.



REVISIONS	DESCRIPTION
DATE	

SCALE: 1/20 XREF  
DATE: 1/28/17  
DESIGN:  
DRAWN: CJF  
CHECKED: KHW  
DWG. - R:2017 - MSC SURVEYING - CONSTANCE TAYLOR (CONSTANCE TAYLOR.DWG)

**PROPERTY SURVEY FOR CONSTANCE TAYLOR**  
4317 S 3350 W, WEST HAVEN UT 84401  
LOCATED IN THE NORTHWEST QUARTER OF SECTION 10,  
TOWNSHIP 5 NORTH, RANGE 2 WEST, S.L.B. AND M.

**GARDNER ENGINEERING**  
CIVIL - LAND PLANNING  
MUNICIPAL - LAND SURVEYING  
5150 SOUTH 875 EAST, CODY, UT  
OFFICE: 801-438-0211 FAX: 801-438-0066

**S1**  
1