



**AS-SURVEYED BOUNDARY DESCRIPTION**

A PART OF THE SOUTHWEST QUARTER OF SECTION 24, TOWNSHIP 3 NORTH, RANGE 4 EAST, OF THE SALT LAKE BASE AND MERIDIAN. BEGINNING AT A POINT LOCATED NORTH 90°00'00\"/>

**AS-SURVEYED BOUNDARY DESCRIPTION**

A PART OF THE SOUTHWEST QUARTER OF SECTION 24, TOWNSHIP 3 NORTH, RANGE 4 EAST, OF THE SALT LAKE BASE AND MERIDIAN. BEGINNING AT A POINT LOCATED SOUTH 89°23'44\"/>

**AS-SURVEYED BOUNDARY DESCRIPTION**

A PART OF THE SOUTHWEST QUARTER OF SECTION 24, TOWNSHIP 3 NORTH, RANGE 4 EAST, OF THE SALT LAKE BASE AND MERIDIAN. BEGINNING AT A POINT LOCATED SOUTH 89°23'44\"/>

**AS-SURVEYED BOUNDARY DESCRIPTION**

A PART OF THE SOUTHWEST QUARTER OF SECTION 24, TOWNSHIP 3 NORTH, RANGE 4 EAST, OF THE SALT LAKE BASE AND MERIDIAN. BEGINNING AT A POINT LOCATED SOUTH 89°23'44\"/>

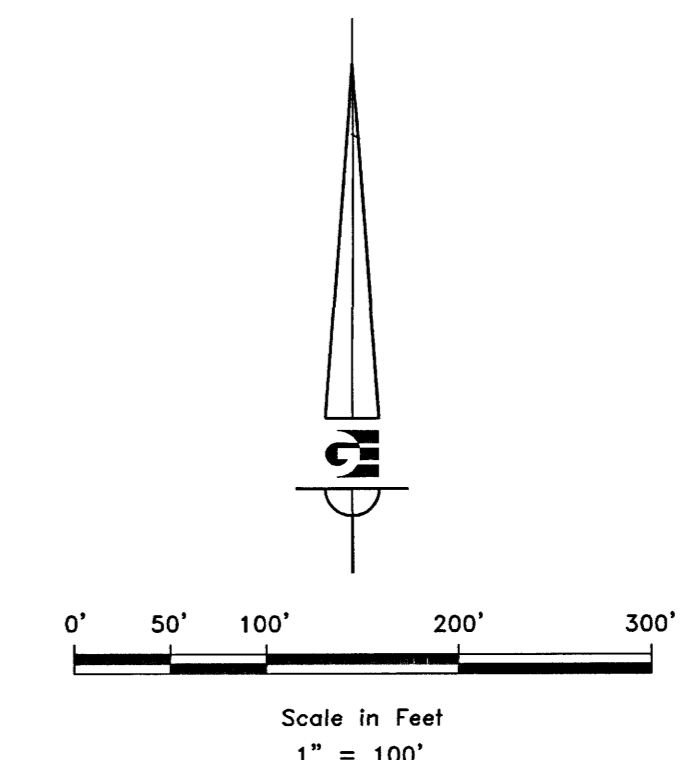

- LEGEND**
- ◆ WEBER COUNTY MONUMENT AS NOTED
  - SET 24\"/>

**NARRATIVE**

THE PURPOSE OF THE SURVEY WAS TO ESTABLISH THE BOUNDARY, TOPOGRAPHY AND THE EXISTING IMPROVEMENTS OF PARCEL NS-924-926 AS SHOWN AND DESCRIBED HEREON. THE SURVEY WAS ORDERED BY ART MILLER. THE CONTROL USED TO ESTABLISH THE BOUNDARY WAS THE EXISTING SUMMIT COUNTY SURVEY MONUMENTATION AS SHOWN AND NOTED HEREON. THE BASIS OF BEARING IS THE SOUTH LINE OF THE SOUTHEAST QUARTER OF SECTION 24, TOWNSHIP 3 NORTH, RANGE 4 EAST, OF THE SALT LAKE BASE AND MERIDIAN WHICH BEARS SOUTH 89°23'44\"/>

**SURVEYOR'S CERTIFICATE**

I, KLINT H. WHITNEY, DO HEREBY CERTIFY THAT I AM A LICENSED PROFESSIONAL LAND SURVEYOR IN THE STATE OF UTAH AND THAT I HOLD CERTIFICATE NO. 8227228 IN ACCORDANCE WITH TITLE 58, CHAPTER 22, OF THE PROFESSIONAL ENGINEERS AND LAND SURVEYORS ACT; I FURTHER CERTIFY THAT BY AUTHORITY OF THE OWNERS I HAVE COMPLETED A SURVEY OF THE PROPERTY DESCRIBED ON THIS RECORD OF SURVEY PLAT IN ACCORDANCE WITH SECTION 17-23-20 AND HAVE VERIFIED ALL MEASUREMENTS; THAT THE REFERENCE MONUMENTS SHOWN ON THIS RECORD OF SURVEY PLAT ARE LOCATED AS INDICATED AND ARE SUFFICIENT TO RETRACE OR REESTABLISH THIS SURVEY; AND THAT THE INFORMATION SHOWN HEREIN IS SUFFICIENT TO ACCURATELY ESTABLISH THE LATERAL BOUNDARIES OF THE HEREIN DESCRIBED TRACT OF REAL PROPERTY.

SIGNED THIS 13<sup>TH</sup> DAY OF DECEMBER, 2017.



SCALE: 1" = 100'

DATE: 4/03/17

DESIGN: \_\_\_\_\_

DRAWN: KHW

CHECKED: KHW

DWG. NO.: R1001 - MISC SURVEY 1722 - ART MILLER SURVEY FOR DWGART MILLER DWG

REVISIONS	DESCRIPTION

RECEIVED

DEC 13 2017

BY: 5890

PROPERTY SURVEY FOR ART MILLER

2731 NORTH 850 EAST

LOCATED IN THE SOUTHEAST QUARTER OF SECTION 28,

TOWNSHIP 7 NORTH, RANGE 1 WEST, S.L.B. AND M.

**GARDNER ENGINEERING**

CIVIL - LAND PLANNING

MUNICIPAL - LAND SURVEYING

5150 SOUTH 975 EAST OGDEN, UT

PHONE: 801-476-0202 FAX: 801-476-0066

S1

1