

**RECORD BOUNDARY DESCRIPTION 22-023-0069**

PART OF THE NORTHEAST QUARTER OF SECTION 29, TOWNSHIP 7 NORTH, RANGE 1 EAST, SALT LAKE BASE AND MERIDIAN: BEGINNING AT A POINT ON THE EAST LINE OF 3500 EAST STREET, SOUTH 23°27'22" FEET FROM THE NORTH QUARTER CORNER OF SAID SECTION 29; RUNNING THENCE EAST 278 FEET; THENCE SOUTH 23°28'09" EAST 161.88 FEET; THENCE TO THE RIGHT ALONG THE ARC OF A 212.49 FOOT RADIUS CURVE 96.42 FEET, THE LONG CHORD OF WHICH BEARS SOUTH 77°00' WEST 95.60 FEET; THENCE WEST 249.32 FEET; THENCE NORTH 170 FEET TO THE POINT OF BEGINNING.

**RECORD BOUNDARY DESCRIPTION 22-023-0117**

PART OF THE NORTHEAST QUARTER OF SECTION 29, TOWNSHIP 7 NORTH, RANGE 1 EAST, SALT LAKE MERIDIAN, U.S. SURVEY: BEGINNING AT A POINT SOUTH 22°00' FEET AND EAST 276.95 FEET OF THE NORTH QUARTER CORNER OF SAID SECTION 29, RUNNING THENCE SOUTH 52°25'20" EAST 266.97 FEET; THENCE SOUTH 30°00' WEST 115 FEET; THENCE SOUTHERLY ALONG THE ARC OF A 212.49 FOOT RADIUS CURVE TO THE RIGHT 126.10 FEET, (LC=SOUTH 47°00' WEST 124.25 FEET) THENCE NORTH 23°28'09" WEST 161.88 FEET; THENCE NORTH 197 FEET TO POINT OF BEGINNING.

**RECORD BOUNDARY DESCRIPTION 22-023-0093**

PART OF THE NORTHEAST QUARTER OF SECTION 29, TOWNSHIP 7 NORTH, RANGE 1 EAST, SALT LAKE BASE AND MERIDIAN, U.S. SURVEY: BEGINNING AT A POINT 2317.77 FEET SOUTH AND 585.32 FEET EAST OF THE NORTH QUARTER CORNER OF SAID SECTION 29, RUNNING THENCE SOUTH 60°00' EAST 185 FEET; THENCE SOUTH 14°11'53" WEST 207.85 FEET; THENCE NORTH 60°00' WEST 241.60 FEET; THENCE NORTH 30°00' EAST 200 FEET TO THE POINT OF BEGINNING.

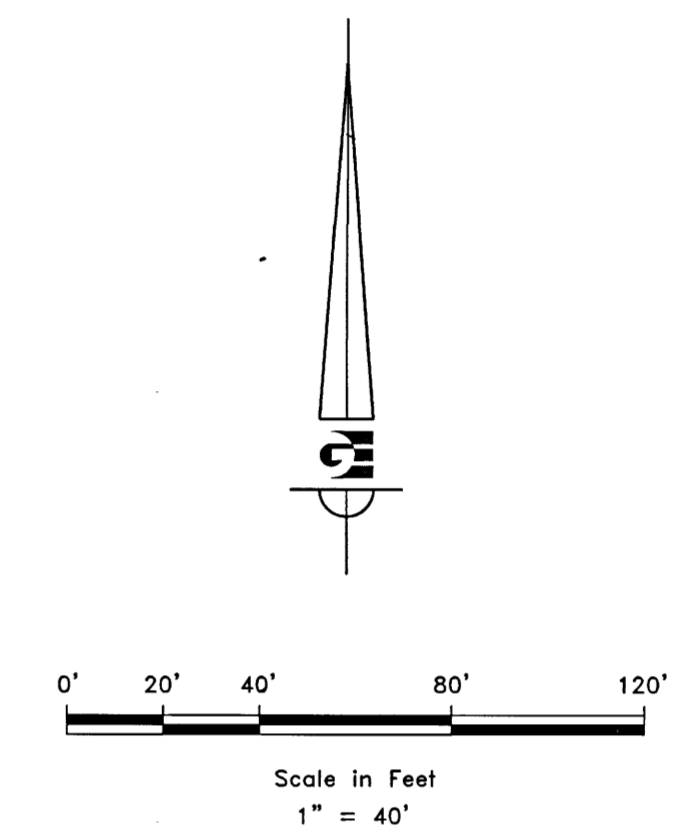

SCALE:	1:40 XREF
DATE:	11/20/17
DESIGN:	
DRAWN:	KHW
CHECKED:	KHW
DWG.: R3201 - MISC SURVEY PLAT 117 - DESIREE STOKES SURVEY COMPANY STOKES ROAD DWG	

**RECEIVED**  
OCT 13 2017  
BY: 5895

PROPERTY SURVEY FOR STOKES RCM RANCH TRUST  
3126 N 3500 EAST, EDEN, WEBER COUNTY, UTAH  
LOCATED IN THE NORTHEAST QUARTER OF SECTION 29,  
TOWNSHIP 7 NORTH, RANGE 1 EAST, S.L.B. AND M.

**GARDNER ENGINEERING**  
CIVIL - LAND PLANNING  
MUNICIPAL - LAND SURVEYING  
150 SOUTH 275 EAST, EDEN, UT  
PHONE: 801-426-1020 FAX: 801-426-1056

**KLINT H. WHITNEY**  
PROFESSIONAL LAND SURVEYOR  
8227228  
STATE OF UTAH

**S1**  
1