

BOUNDARY DESCRIPTION

A PART OF LOT 10, BLOCK 39, PLAT "C", OGDEN CITY SURVEY, MORE PARTICULARLY DESCRIBED AS FOLLOWS:
 BEGINNING AT A POINT ON THE EASTERLY RIGHT-OF-WAY LINE OF ECCLES AVENUE BEING LOCATED NORTH 88°42'35" WEST 379.43 FEET ALONG THE MONUMENTED CENTERLINE OF 23RD STREET BETWEEN THE OGDEN CITY CENTERLINE MONUMENT AT 23RD STREET AND VAN BUREN AVENUE AND THE OGDEN CITY CENTERLINE MONUMENT AT 23RD STREET AND ECCLES AVENUE AND NORTH 1°17'39" EAST 191.27 FEET ALONG THE CALCULATED CENTERLINE OF ECCLES AVENUE AND NORTH 90°00'00" EAST 33.01 FEET FROM THE CENTERLINE MONUMENT AT 23RD STREET AND VAN BUREN AVENUE, RUNNING THENCE ALONG SAID RIGHT-OF-WAY LINE NORTH 1°17'39" EAST 26.09 FEET; THENCE SOUTH 88°42'35" EAST 140.00 FEET; THENCE SOUTH 1°17'23" WEST 26.09 FEET; THENCE NORTH 88°42'35" WEST 140.00 FEET TO THE POINT OF BEGINNING, CONTAINING 3,653 SQ. FT. OR 0.840 ACRE, MORE OR LESS.

SCALE: 1/2" XREF	DATE: 8/28/17
DESIGN: SGP	DRAWN: SGP
CHECKED: KHW	DWG.: E:\2017 - MISC SURVEYS\1719 - PEG HOOVER SURVEY\DWG\PEGSURV.DWG

RECEIVED
 OCT 13 2017
 BY: 5897

PROPERTY SURVEY FOR PEG HOOVER
 2270 ECCLES AVENUE, OGDEN, UTAH
 LOCATED IN THE SOUTHEAST QUARTER OF SECTION 28,
 TOWNSHIP 6 NORTH, RANGE 1 WEST, S.L.B. AND M.

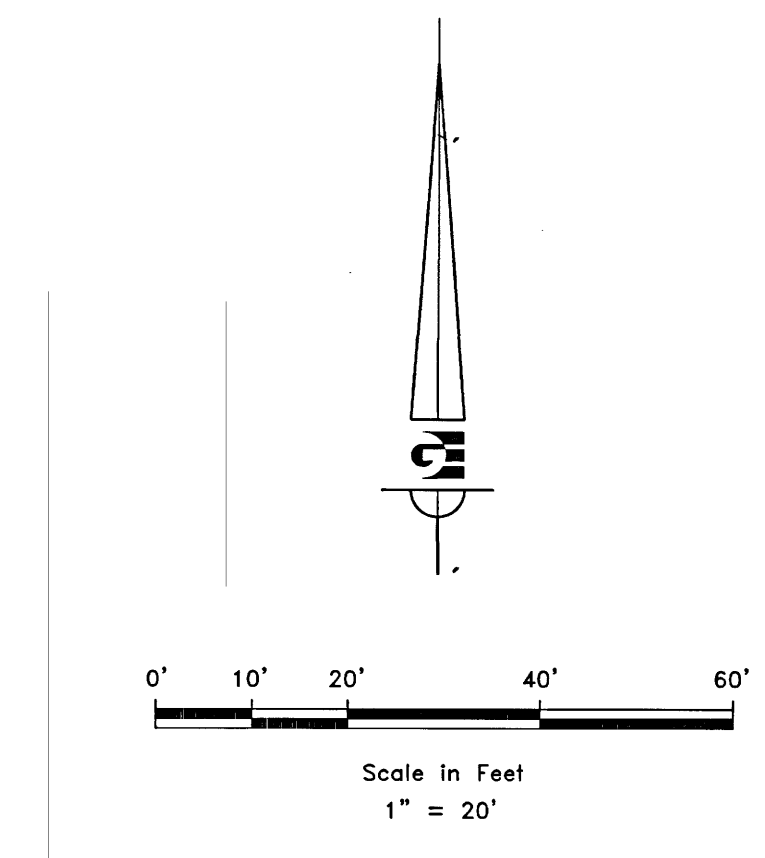

- LEGEND**
- ◆ OGDEN CITY CENTERLINE MONUMENT AS NOTED
 - SET 24" REBAR AND CAP MARKED GARDNER ENGINEERING
 - PROPERTY BOUNDARY
 - - - ADJACENT PARCEL
 - CENTERLINE
 - - - EXISTING FENCE LINE
 - ORIGINAL LOT

NARRATIVE

THE PURPOSE OF THE SURVEY WAS TO ESTABLISH THE PROPERTY BOUNDARY FOR PARCEL NO. 02-037-0063 AS SHOWN AND DESCRIBED HEREON. THE SURVEY WAS ORDERED BY PEG HOOVER. THE CONTROL USED TO ESTABLISH THE BOUNDARY WAS THE EXISTING OGDEN CITY CENTERLINE MONUMENTATION AS SHOWN AND NOTED HEREON. CURRENT VESTING DEED RECORDED AS E82711692, AS WELL AS ADJACENT DEEDS AND CURRENT OCCUPATION WERE ALSO USED. THE BASIS OF BEARING IS THE LINE BETWEEN THE OGDEN CITY CENTERLINE MONUMENT AT 23RD STREET AND VAN BUREN AVENUE AND THE OGDEN CITY CENTERLINE MONUMENT AT 23RD STREET AND ECCLES AVENUE WHICH BEARS NORTH 88°42'35" WEST WEBER COUNTY GRID BEARING.

SURVEYOR'S CERTIFICATE

I, KLINT H. WHITNEY, DO HEREBY CERTIFY THAT I AM A LICENSED PROFESSIONAL LAND SURVEYOR IN THE STATE OF UTAH AND THAT I HOLD CERTIFICATE NO. 8227228 IN ACCORDANCE WITH TITLE 58, CHAPTER 22, OF THE PROFESSIONAL ENGINEERS AND LAND SURVEYORS ACT; I FURTHER CERTIFY THAT BY AUTHORITY OF THE OWNERS I HAVE COMPLETED A SURVEY OF THE PROPERTY DESCRIBED ON THIS RECORD OF SURVEY PLAT IN ACCORDANCE WITH SECTION 17-23-20 AND HAVE VERIFIED ALL MEASUREMENTS; THAT THE REFERENCE MONUMENTS SHOWN ON THIS RECORD OF SURVEY PLAT ARE LOCATED AS INDICATED AND ARE SUFFICIENT TO RETRACE OR REESTABLISH THIS SURVEY; AND THAT THE INFORMATION SHOWN HEREIN IS SUFFICIENT TO ACCURATELY ESTABLISH THE LATERAL BOUNDARIES OF THE HEREIN DESCRIBED TRACT OF REAL PROPERTY.

SIGNED THIS 20TH DAY OF NOVEMBER, 2017.

PROFESSIONAL LAND SURVEYOR
 11-20-17
 8227228
 Klint H. Whitney
 STATE OF UTAH
 KLINT H. WHITNEY, PLS NO. 8227228

GARDNER ENGINEERING
 CIVIL - LAND PLANNING
 MUNICIPAL - LAND SURVEYING
 5150 SOUTH 875 EAST OGDEN, UT
 OFFICE: 801-476-1020 FAX: 801-476-1066

S1
 1