

Northwest Corner of Sec. 26,  
T. 7 N., R. 2 W., SLB&M  
Calculated Position from Witness  
Corner 10.00' to the south.

S 0°30'33" E Witness Corner  
523.51'

North Quarter Corner of Sec. 26,  
T. 7 N., R. 2 W., SLB&M  
Weber Co. Brass Cap Monument

Section Line - Basis of Bearing  
N 89°46'57" E 2656.71'

**LEGEND**

- Subject Property Line
- Adjoining Property Line
- Previous Property Line
- Centerline
- Ditch
- Field Separation Line
- Fence Line (Wire)
- Fence Line (wood or Vinyl)
- Street Monument
- Found curb nail
- Set 5/8"x24" Rebar With Cap
- Section Corner
- Calculated Section Corner

**Lot 13-R**

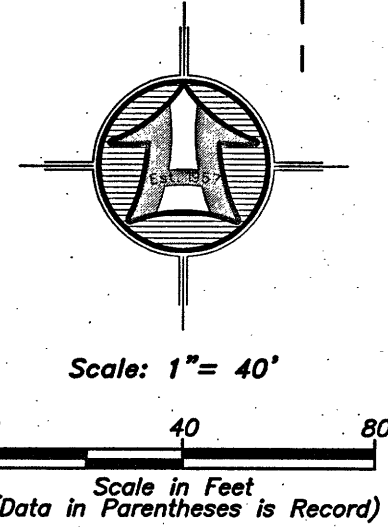

**Narrative**

The purpose of this survey was to establish and set the property corners of the parcel as shown and described hereon. The survey was ordered by Brad Jackson. The control used to establish the property corners was the existing Milkyway Subdivision monumentation found within said subdivision along with the Weber County Survey Monumentation surrounding Section 26, T7N, R2W, SLB&M. The basis of bearing is the North line of said Section which bears North 89°46'57" East, Utah North, State Plane, calculated N.A.D.83 bearing.

**AS RECORDED BOUNDARY DESCRIPTION**

ALL OF LOT 1, MILKYWAY SUBDIVISION, FARR WEST CITY, WEBER COUNTY, UTAH, EXCEPTING THEREFROM THE FOLLOWING: A PART OF THE NORTHWEST QUARTER OF SECTION 26, TOWNSHIP 7 NORTH, RANGE 2 WEST, SALT LAKE BASE & MERIDIAN.

BEGINNING AT A POINT OF THE SOUTH RIGHT-OF-WAY LINE OF 3300 NORTH STREET LOCATED 523.51 FEET SOUTH 00°30'30" EAST FROM THE NORTHWEST CORNER OF SAID SECTION 26, RUNNING THENCE ALONG SAID RIGHT-OF-WAY LINE THE FOLLOWING TWO (2) COURSES: (1) NORTH 60°26'31" EAST 34.28 FEET, (2) NORTH 64°34'30" EAST 71.69 FEET; THENCE SOUTH 25°17'46" EAST 6.02 FEET; THENCE TO THE RIGHT ALONG THE ARC OF A 119.98 FOOT RADIUS CURVE A DISTANCE OF 51.92 FEET, CHORD BEARS SOUTH 12°54'00" EAST 51.51 FEET; THENCE SOUTH 00°30'13" EAST 79.88 FEET; THENCE TO THE LEFT ALONG THE ARC OF A 330.00 FOOT RADIUS CURVE A DISTANCE OF 50.46 FEET, CHORD BEARS SOUTH 04°53'02" EAST 50.41 FEET; THENCE SOUTH 89°29'46" WEST 112.40 FEET; THENCE NORTH 00°30'34" WEST 139.07 FEET TO THE POINT OF BEGINNING.

**SURVEYOR'S CERTIFICATE**

I, K. Greg Hansen, do hereby certify that I am a Registered Professional Land Surveyor in the State of Utah in accordance with Title 58, Chapter 22, Professional Engineers and Professional Land Surveyors Act; and by the authority of the owners, I have completed a survey of the property described and shown hereon this plat in accordance with Section 17-23-17 and have verified all measurements, and that the same has been surveyed and monuments have been located and/or placed on the ground as represented on the plat hereon.

Signed this 22<sup>ND</sup> day of December, 2017.

K. Greg Hansen PLS  
Utah Land Surveyor Licence No. 167819

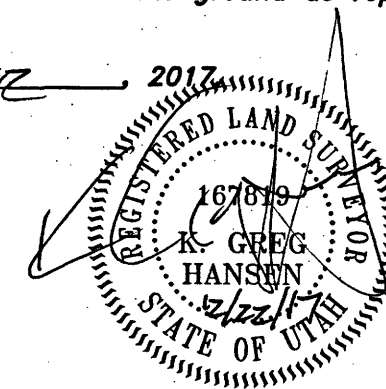

RECEIVED  
JAN 2 2018  
BY: 5908

Drawn By: kgh Date: 11/14/17  
Designed By:  
Checked By:  
Approved By:  
Scale: 1" = 40'  
Drawing File: 17-3-229v15  
JOB NUMBER: 17-3-229

Property Survey for  
**Brad Jackson**  
North of 3243 North 2700 West  
Farr West City, Weber County, Utah  
A Part of the Northwest Quarter of  
Section 26, T 7 N., R 2 W., S.L.B.&M.

Sheet  
**1**  
Of  
**1**  
Sheets

No.	Date	By	Revision

**HANSEN & ASSOCIATES, INC.**  
Consulting Engineers and Land Surveyors  
538 North Main Street, Brigham, Utah 84302  
Visit us at [www.hais.net](http://www.hais.net)  
Brigham City Ogden Logan  
(435) 723-3491 (801) 399-4905 (435) 752-8272  
Celebrating 60 Years of Business

