

AS SURVEYED BOUNDARY DESCRIPTION

THE NORTHEAST QUARTER OF THE SOUTHWEST QUARTER OF SECTION 13, TOWNSHIP 7 NORTH, RANGE 2 EAST OF THE SALT LAKE BASE AND MERIDIAN, MORE PARTICULARLY DESCRIBED AS FOLLOWS:

BEGINNING AT THE SOUTHWEST CORNER OF THE NORTHEAST QUARTER OF THE SOUTHWEST QUARTER OF SAID SECTION 13 LOCATED 1351.46 FEET NORTH 02°05'04" EAST ALONG THE NORTH - SOUTH CENTER SECTION LINE FROM THE SOUTH QUARTER CORNER OF SAID SECTION 13;

RUNNING THENCE ALONG THE BOUNDARY OF SAID NORTHEAST QUARTER OF THE SOUTHWEST QUARTER THE FOLLOWING FOUR (4) COURSES: (1) SOUTH 89°50'36" WEST 1304.71 FEET; (2) NORTH 02°05'22" EAST 1339.10 FEET TO A POINT ON THE EAST - WEST CENTER SECTION LINE; (3) NORTH 89°18'04" EAST 1305.14 FEET ALONG SAID EAST - WEST CENTER SECTION LINE TO THE CENTER OF SAID SECTION; AND (4) SOUTH 02°05'04" WEST 1351.46 FEET ALONG THE NORTH - SOUTH CENTER SECTION LINE TO THE POINT OF BEGINNING. CONTAINING 40.26 ACRES.

BASIS OF BEARING IS THE SOUTH LINE OF THE SOUTHWEST QUARTER WHICH BEARS NORTH 89°36'51" WEST BETWEEN THE FOUND MONUMENTS AT THE SOUTH QUARTER CORNER AND THE SOUTHWEST CORNER OF SAID SECTION 13.

SURVEYOR'S CERTIFICATE

I, K. Greg Hansen, do hereby certify that I am a Registered Professional Land Surveyor in the State of Utah in accordance with Title 58, Chapter 22, Professional Engineers and Professional Land Surveyors Act; and by the authority of the owners, I have completed a survey of the property described and shown hereon this plat in accordance with Section 17-23-17 and have verified all measurements, and that the same has been surveyed and monuments have been located and/or Placed on the ground as represented on the plat hereon.

Signed this 16th day of February, 2018.

K. Greg Hansen PLS
Utah Land Surveyor Licence No. 167819

NARRATIVE

The purpose of this survey was to establish and set the property corners of the parcel as shown and described hereon. The survey was ordered by Marco Miconi. The control used to establish the property corners were the existing U.S.G.L.O. Monuments from the 1941 Dependant Survey surrounding Section 13, 17N, R2E, SLB&M and ROS# 3578 as recorded in the Weber County Recorder's Office. The basis of bearing is the South line of the Southwest Quarter of said Section which bears North 89°36'51" West, Utah North, State Plane, Calculated N.A.D.83 Bearing.

- LEGEND**
- Subject Property Line
 - - - Adjoining Property Line
 - - - Previous Property Line
 - Centerline
 - - - Ditch
 - - - Field Separation Line
 - - - Fence Line (Wire)
 - - - Fence Line (wood or Vinyl)
 - - - Street Monument
 - Found rebar set by others
 - Set 5/8"x24" Rebar With Cap
 - Section Corner
 - Calculated Section Corner

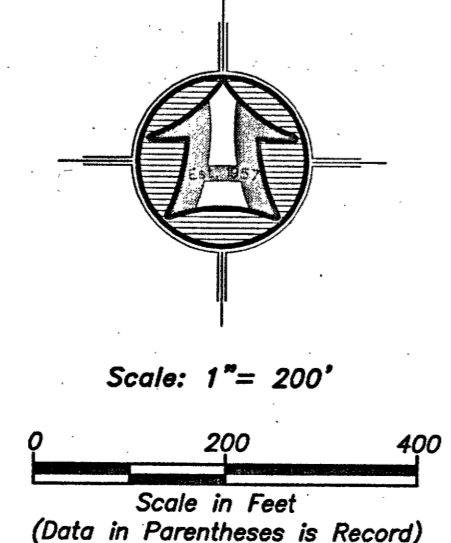

RECEIVED
APR 04 2018
BY: 5964

<p>Drawn By: RS Date: 02/15/2018</p> <p>Designed By:</p> <p>Checked By:</p> <p>Approved By:</p> <p>Scale: 1" = 200'</p> <p>Drawing File: 18-3-13 v15.dwg</p> <p>JOB NUMBER: 18-3-13</p>	<p style="text-align: center;">HANSEN & ASSOCIATES, INC. Consulting Engineers and Land Surveyors 538 North Main Street, Brigham, Utah 84302 Visit us at www.hais.net Brigham City, Utah (801) 735-5400 Ogden, Utah (435) 735-5400 Logan, Utah (435) 735-5400 Celebrating 60 Years of Business</p>
<p>Property Survey for Renato Miconi Weber County, Utah A Part of the Southwest Quarter of Section 13 Township 7 North, Range 2 East, S.L.B.&M.</p>	
<p>Sheet 1 of 1 Sheets</p>	