

BOUNDARY DESCRIPTION
 ALL OF LOT 389, EVERGREEN PARK SUBDIVISION NUMBER 1, WEBER COUNTY, UTAH.

FOUND NORTH QUARTER
 SEC. 30, T7N, R3E, S.L.B. & M.
 WEBER COUNTY
 2.5" US 1944 GLO BRASS CAP 1"
 ABOVE GROUND

FOUND NORTHEAST QUARTER
 SEC. 30, T7N, R3E, S.L.B. & M.
 WEBER COUNTY
 2.5" US 1944 GLO BRASS CAP 1"
 ABOVE GROUND

SCALE: 1" = 60'	DATE: 06/04/2018	DESIGN: _____	DRAWN: JTN	CHECKED: KHW
REVISIONS	DESCRIPTION			
DATE				

DATE: JUN 28 2018
 BY: 6059

PROPERTY SURVEY FOR BRAD REEVES
 3313 NORTH PINE CANYON WAY
 LOCATED IN THE NORTHEAST QUARTER OF SECTION 30,
 TOWNSHIP 7 NORTH, RANGE 3 EAST, S.L.B. AND M.

GARDNER ENGINEERING
 CIVIL - LAND PLANNING
 MUNICIPAL - LAND SURVEYING
 5150 SOUTH 575 EAST OGDEN, UT
 OFFICE: 801-426-0202 FAX: 801-426-0066

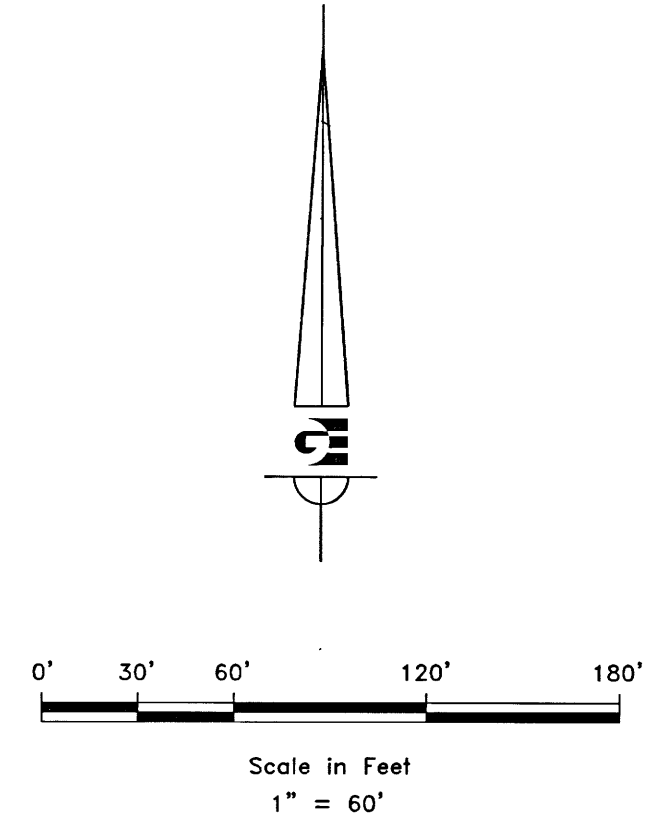

- LEGEND**
- FOUND REBAR
 - ⊕ SET POINT ON LINE
 - ⊕ WEBER COUNTY MONUMENT AS NOTED
 - SET 24" REBAR & CAP MARKED GARDNER ENGINEERING
 - SUBDIVISION BOUNDARY
 - LOT LINE
 - - - ADJACENT PARCEL
 - - - SECTION LINE
 - - - EASEMENT
 - - - EXISTING FENCE LINE

NARRATIVE

THE PURPOSE OF THE SURVEY WAS TO REESTABLISH THE BOUNDARIES OF THE PARCEL AS SHOWN AND DESCRIBED HEREON. THE SURVEY WAS ORDERED BY BRAD REEVES. THE CONTROL USED TO ESTABLISH THE EXISTING WEBER COUNTY SURVEY MONUMENTATION AS SHOWN AND NOTED HERON. THE OWNERSHIP PLAT OF HOLT SUBDIVISION WAS USED TO ESTABLISH THE BOUNDARY AND QUITCLAIM DEED RECORDED AS E#1739184. THE BASIS OF BEARING IS THE NORTH LINE OF THE NORTHEAST QUARTER OF SECTION 30, TOWNSHIP 7 NORTH, RANGE 3 EAST, OF THE SALT LAKE BASE AND MERIDIAN WHICH BEARS NORTH 89°48'47" WEST, UTAH NORTH NAD83 STATE PLANE GRID BEARING.

SURVEYOR'S CERTIFICATE

I, KLINT H. WHITNEY, DO HEREBY CERTIFY THAT I AM A LICENSED PROFESSIONAL LAND SURVEYOR IN THE STATE OF UTAH AND THAT I HOLD CERTIFICATE NO. 8227228 IN ACCORDANCE WITH TITLE 58, CHAPTER 22, OF THE PROFESSIONAL ENGINEERS AND LAND SURVEYORS ACT. I FURTHER CERTIFY THAT BY AUTHORITY OF THE OWNERS I HAVE COMPLETED A SURVEY OF THE PROPERTY DESCRIBED ON THIS RECORD OF SURVEY PLAT IN ACCORDANCE WITH SECTION 17-23-20 AND HAVE VERIFIED ALL MEASUREMENTS, THAT THE REFERENCE MONUMENTS SHOWN ON THIS RECORD OF SURVEY PLAT ARE LOCATED AS INDICATED AND ARE SUFFICIENT TO RETRACE OR REESTABLISH THIS SURVEY, AND THAT THE INFORMATION SHOWN HEREIN IS SUFFICIENT TO ACCURATELY ESTABLISH THE LATERAL BOUNDARIES OF THE HEREIN DESCRIBED TRACT OF REAL PROPERTY.

SIGNED THIS 25TH DAY OF JUNE, 2018.

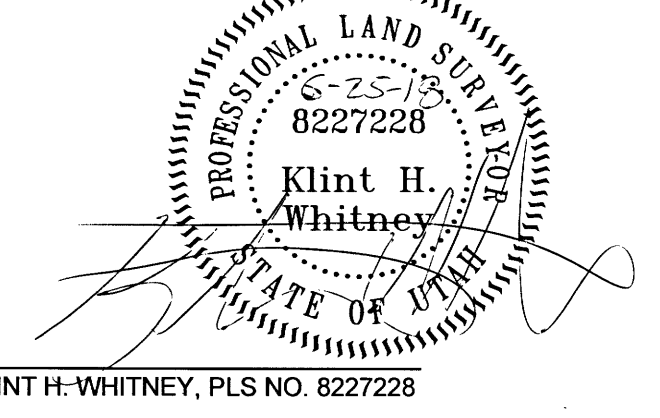

S1
 1

KLINT H. WHITNEY, PLS NO. 8227228