

BOUNDARY DESCRIPTION
 ALL OF LOT 2, BLOCK 2, OAK HILLS SUBDIVISION, OGDEN CITY, WEBER COUNTY, UTAH.

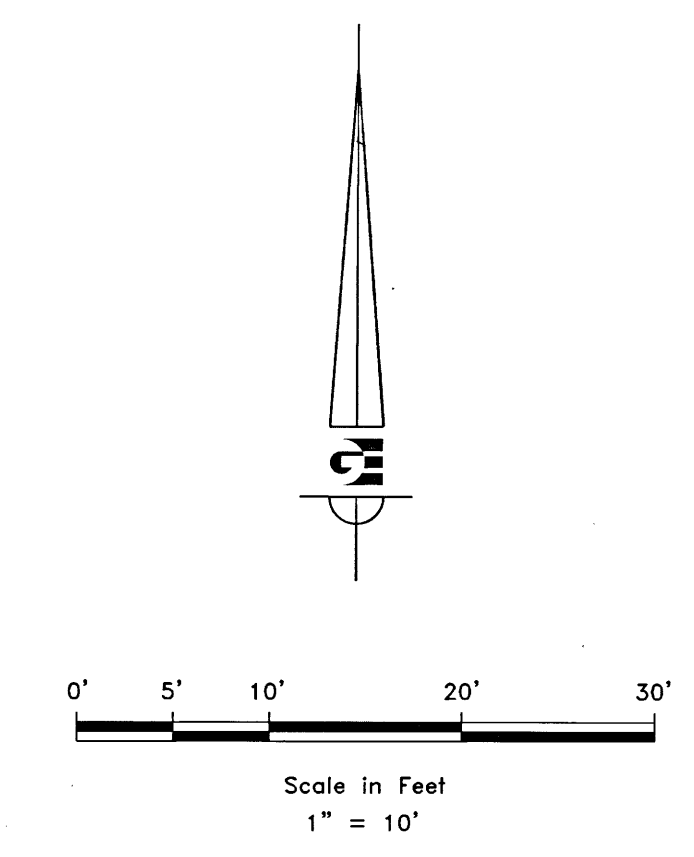

- LEGEND**
- ◆ CENTERLINE MONUMENT AS NOTED
 - SET 24" REBAR AND CAP MARKED GARDNER ENGINEERING
 - LOT LINE
 - - - ADJACENT PARCEL
 - - - SECTION LINE
 - - - EASEMENT
 - - - EXISTING BUILDING
 - - - EXISTING CONCRETE
 - - - EXISTING FENCE LINE
 - ~ ~ ~ ROCK WALL

NARRATIVE

THE PURPOSE OF THE SURVEY WAS TO ESTABLISH AND SET THE PROPERTY CORNERS OF THE PARCEL AS SHOWN AND DESCRIBED HEREON. THE SURVEY WAS ORDERED BY AMBER JOHN. THE CONTROL USED TO ESTABLISH THE PROPERTY CORNERS WAS THE EXISTING WEBER COUNTY SURVEY MONUMENTATION SURROUNDING SECTION 34, TOWNSHIP 6 NORTH, RANGE 1 WEST, OF THE SALT LAKE BASE AND MERIDIAN AND THE FOUND GREAT BASIN SET REBAR. THE BASIS OF BEARING IS THE LINE BETWEEN THE CENTERLINE MONUMENT AT 26TH STREET AND 1825 EAST STREET AND THE CENTERLINE MONUMENT IN THE CUL-DE-SAC OF SHAMROCK DRIVE WHICH BEARS SOUTH 42°13'05" WEST, OGDEN CITY, WEBER COUNTY, UTAH.

SURVEYOR'S CERTIFICATE

I, KLINT H. WHITNEY, DO HEREBY CERTIFY THAT I AM A LICENSED PROFESSIONAL LAND SURVEYOR IN THE STATE OF UTAH AND THAT I HOLD CERTIFICATE NO. 8227228 IN ACCORDANCE WITH TITLE 58, CHAPTER 22, OF THE PROFESSIONAL ENGINEERS AND LAND SURVEYORS ACT; I FURTHER CERTIFY THAT BY AUTHORITY OF THE OWNERS I HAVE COMPLETED A SURVEY OF THE PROPERTY DESCRIBED ON THIS RECORD OF SURVEY PLAT IN ACCORDANCE WITH SECTION 17-23-20 AND HAVE VERIFIED ALL MEASUREMENTS; THAT THE REFERENCE MONUMENTS SHOWN ON THIS RECORD OF SURVEY PLAT ARE LOCATED AS INDICATED AND ARE SUFFICIENT TO RETRACE OR REESTABLISH THIS SURVEY; AND THAT THE INFORMATION SHOWN HEREIN IS SUFFICIENT TO ACCURATELY ESTABLISH THE LATERAL BOUNDARIES OF THE HEREIN DESCRIBED TRACT OF REAL PROPERTY.

SIGNED THIS 27th DAY OF JULY, 2018.

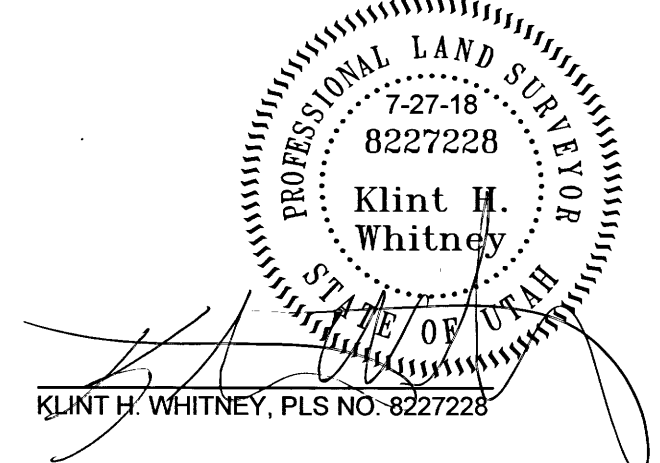

H STEVEN HOISINGTON
 140740007

BRUECKNER FAMILY TRUST
 170740006

SCALE	1:10 XREF
DATE	08/17/17
DESIGN	
DRAWN	CF
CHECKED	KHW
DWG.	R3001 - MISC SURVEY/1718 - AMBER JOHN SURVEY/2018/08/17

RECEIVED
 JUL 27 2018
 BY: 6065

PROPERTY SURVEY FOR AMBER JOHN
 2676 SHAMROCK DR OGDEN, UT
 LOCATED IN THE NORTHEAST QUARTER OF SECTION 34,
 TOWNSHIP 6 NORTH, RANGE 1 WEST, S.L.B. AND M.

GARDNER ENGINEERING
 CIVIL - LAND PLANNING
 MUNICIPAL - LAND SURVEYING
 5150 SOUTH 575 EAST OGDEN, UT
 OFFICE - BOX 426102 PLAZA - BOX 426106

S1
 1