

West Quarter Cor. of Sec. 17, T6N, R2E, SLB&M Fnd. Weber Co. Surveyor Brass Cap Mon. Dated 1982

Northwest Cor. of Sec. 17, T6N, R2E, SLB&M Fnd. Weber Co. Surveyor Brass Cap Mon. Dated 1994

Lowe Properties, LC
21-026-0042

Bailey's Back Five
Lot 1
Lenny Bailey
21-099-0001

Halvor Roosevelt Bailey
21-026-0045
Containing 7.622 Acres

ESPL Investments Limited
21-026-0046

Leon Fielding
21-026-0043

Leon Fielding
21-026-0044

State
S 88°43'35" E
921.05'

Highway
S 88°43'35" E

U-39
S 88°43'35" W

- LEGEND**
- Subject Property Line
 - - - Adjoining Property Line
 - - - Previous Property Line
 - Centerline
 - - - Ditch
 - - - Field Separation Line
 - - - Fence Line (Wire)
 - - - Fence Line (wood or Vinyl)
 - - - Street Monument
 - - - Found rebar set by others
 - - - Found rebar set by others
 - - - Section Corner

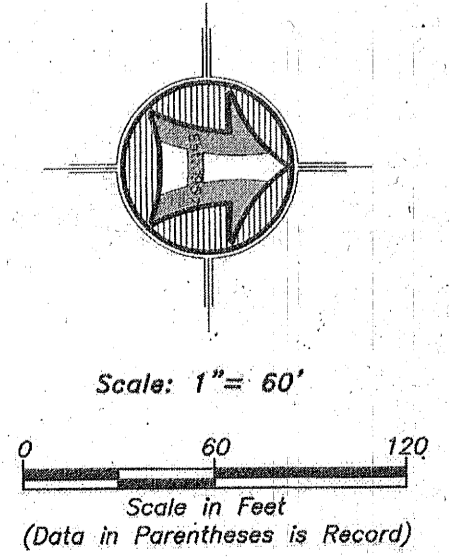

Narrative

The purpose of this survey was to establish and set the property corners of the parcel as shown and described hereon. The survey was ordered by Lyle Bailey. The control used to establish the property corners was the existing Weber County Survey Monumentation surrounding Section 17 T6N, R2E, SLB&M. The deeds in this area call a distance of 706.2 feet south of the northwest corner of said Section 17 as being the Centerline of Highway 39, the measured distance is 731.03' and using the measured distance places the back property lines in harmony with existing fence lines. The west and south property lines follow the Bailey's Back Five Subdivision. The East property line is that as established by HAI in 2011. The basis of bearing is the West line of the northwest quarter said Section which bears South 00°22'13" West Utah North NAD 83 State Plane Grid Bearing.

As Surveyed Boundary Description

A PART OF THE NORTHWEST QUARTER OF SECTION 17, TOWNSHIP 6 NORTH, RANGE 2 EAST OF THE SALT LAKE BASE AND MERIDIAN.

BEGINNING AT THE NORTHEAST CORNER OF LOT 1 OF BAILEY'S BACK FIVE SUBDIVISION FILED AS ENTRY NO. 1970319 IN THE FILES OF THE WEBER COUNTY RECORDER BEING A POINT ON THE SOUTH RIGHT-OF-WAY LINE OF STATE HIGHWAY U-39 LOCATED SOUTH 00°22'13" WEST 731.03 FEET ALONG THE WEST LINE OF SAID NORTHWEST QUARTER TO THE CENTERLINE OF SAID STATE HIGHWAY U-39 AND SOUTH 88°43'35" EAST 921.05 FEET (TO A POINT DESCRIBED OF RECORD AS BEING LOCATED SOUTH 748.05 FEET AND EAST 916.64 FEET FROM THE NORTHWEST CORNER OF SAID SECTION) AND SOUTH 00°24'58" EAST 33.01 FEET FROM THE NORTHWEST CORNER OF SAID NORTHWEST QUARTER;

RUNNING THENCE SOUTH 88°43'35" EAST 318.78 FEET ALONG SAID SOUTH RIGHT-OF-WAY LINE; THENCE SOUTH 00°13'00" EAST 641.34 FEET; THENCE SOUTH 00°13'11" EAST 558.59 FEET TO AN ANGLE POINT ON THE EAST BOUNDARY LINE OF SAID BAILEY'S BACK FIVE SUBDIVISION; THENCE ALONG THE BOUNDARY LINE OF SAID BAILEY'S BACK FIVE SUBDIVISION THE FOLLOWING FIVE (5) COURSES: (1) SOUTH 89°37'52" WEST 193.04 FEET; (2) NORTH 00°34'46" WEST 443.87 FEET; (3) NORTH 89°40'18" WEST 130.02 FEET; (4) NORTH 00°34'46" WEST 111.25 FEET; AND (5) NORTH 00°28'26" EAST 652.44 FEET TO THE POINT OF BEGINNING. CONTAINING 7.622 ACRES.

RECEIVED
SEP 26 2018
BY: 6094

SURVEYOR'S CERTIFICATE

I, K. Greg Hansen, do hereby certify that I am a Registered Professional Land Surveyor in the State of Utah in accordance with Title 58, Chapter 22, Professional Engineers and Professional Land Surveyors Act; and by the authority of the owners, I have completed a survey of the property described and shown hereon this plat in accordance with Section 17-23-17 and have verified all measurements, and that the same has been surveyed and monuments have been located and/or Placed on the ground as represented on the plat hereon.

Signed this 27th day of August, 2018.

K. Greg Hansen PLS
Utah Land Surveyor License No. 167819



Property Survey for
Halvor Roosevelt Bailey Family
8051 East 100 South
Huntsville, Weber County, Utah
A Part of the Northwest Quarter of Section 17,
Township 6 North, Range 2 East, S.L.B.&M.

Drawn By: Lgh	Date: 08/15/18
Designed By:	
Checked By:	
Approved By:	
Scale: 1" = 60'	
Drawing File: 18-3-183v15	
JOB NUMBER: 18-3-183	

HANSEN & ASSOCIATES, INC.
Consulting Engineers and Land Surveyors
538 North Main Street, Brigham, Utah 84302
Visit us at www.hailes.net
Logon
Brigham City, Ogden
(435) 733-3491 (801) 399-9900 (435) 732-8272
Celebrating 60 Years of Business

No.	Date	By	Revision
1			

Sheet
1
of
1
Sheets