

RECEIVED
 SEP 16 2018
 BY: 6096

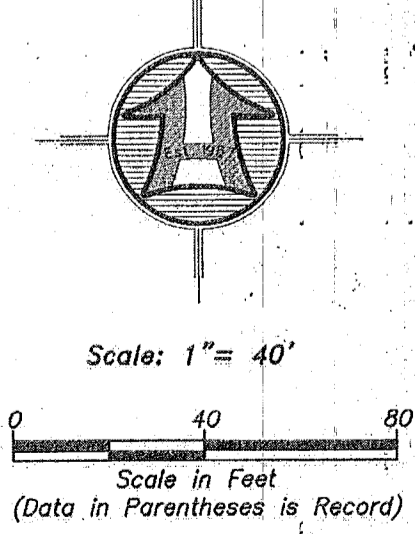

- LEGEND**
- Subject Property Line
 - Adjoining Property Line
 - Previous Property Line
 - Centerline
 - Ditch
 - Field Separation Line
 - Fence Line (Wire)
 - Fence Line (wood or Vinyl)
 - Street Monument
 - Found rebar set by Gardner Eng.
 - Set 5/8"x24" Rebar With Cap
 - Section Corner

Narrative

The Purpose of this Survey was break of the house parcel of the Mary Petrie property as shown and described hereon. The survey was ordered by Joe Adair for Mary. The control used to establish the boundary lines was the boundary survey on the Petrie property done by Gardner Engineering, dated August 16, 2016 along with the Weber County Section Corner monumentation surrounding section 7, T5N, R2W, SLB&M. The basis of bearing is the east line of the southeast quarter of said Section which bears South 00°44'14" West, Utah North, State Plane, Calculated N.A.D.83 Bearing.

Parcel No. 1

A PART OF THE SOUTHEAST QUARTER OF SECTION 7, TOWNSHIP 5 NORTH, RANGE 2 WEST OF THE SALT LAKE BASE AND MERIDIAN.

BEGINNING AT A POINT LOCATED 180.00 FEET SOUTH 00°44'14" WEST AND 485.00 FEET NORTH 89°18'20" WEST FROM THE NORTHEAST CORNER OF SAID SECTION SOUTHEAST QUARTER;

RUNNING THENCE SOUTH 17°48'51" WEST 114.93 FEET; THENCE NORTH 88°55'53" WEST 281.26 FEET TO THE EAST RIGHT-OF-WAY LINE OF 5225 WEST STREET; THENCE NORTH 00°44'14" EAST 288.00 FEET ALONG SAID EAST RIGHT-OF-WAY LINE TO THE NORTHEAST CORNER OF SAID HORSESHOE RANCH SUBDIVISION, SAID POINT BEING LOCATED 800.00 FEET NORTH 89°18'20" WEST FROM THE NORTHEAST CORNER OF SAID SOUTHEAST QUARTER; THENCE SOUTH 89°18'20" EAST 315.00 FEET ALONG THE NORTH LINE OF SAID SOUTHEAST QUARTER; THENCE SOUTH 00°44'14" WEST 180.00 FEET TO THE POINT OF BEGINNING. CONTAINING 2.047 ACRES.

Parcel No. 2

A PART OF THE SOUTHEAST QUARTER OF SECTION 7, TOWNSHIP 5 NORTH, RANGE 2 WEST OF THE SALT LAKE BASE AND MERIDIAN.

BEGINNING AT A POINT LOCATED 180.00 FEET SOUTH 00°44'14" WEST FROM THE NORTHEAST CORNER OF SAID SECTION SOUTHEAST QUARTER;

RUNNING THENCE SOUTH 00°44'14" WEST 263.23 FEET ALONG THE EAST LINE OF SAID SOUTHEAST QUARTER TO THE NORTHEAST CORNER OF HORSESHOE RANCH SUBDIVISION; THENCE ALONG THE NORTH BOUNDARY LINE OF SAID HORSESHOE RANCH SUBDIVISION AND A BOUNDARY LINE AGREEMENT RECORDED AS ENTRY NUMBER 1665614 OF THE WEBER COUNTY RECORDS THE FOLLOWING TWO COURSES; (1) NORTH 88°55'53" WEST 800.01 FEET TO THE EAST RIGHT-OF-WAY LINE OF 5225 WEST STREET; AND (2) NORTH 00°44'14" EAST 150.00 FEET ALONG SAID EAST RIGHT-OF-WAY LINE; THENCE SOUTH 88°55'53" EAST 281.26 FEET; THENCE NORTH 17°48'51" EAST 114.93 FEET; THENCE SOUTH 89°18'20" EAST 485.00 FEET TO THE POINT OF BEGINNING. CONTAINING 4.041 ACRES.

LESS THAT PORTION LYING WITHIN THE 5100 WEST RIGHT-OF-WAY.

Southeast Corner of Sec. 7, T. 5 N., R. 2 W., SLB&M Found Weber County Brass Cap Monument. Dated 1961. Poor Condition.

SURVEYOR'S CERTIFICATE

I, K. Greg Hansen, do hereby certify that I am a Registered Professional Land Surveyor in the State of Utah in accordance with Title 58, Chapter 22, Professional Engineers and Professional Land Surveyors Act; and by the authority of the owners, I have completed a survey of the property described and shown hereon this plat in accordance with Section 17-23-17 and have verified all measurements, and that the same has been surveyed and monuments have been located and/or placed on the ground as represented on the plat hereon.

Signed this 19th day of June, 2018.

K. Greg Hansen PLS
 Utah Land Surveyor License No. 167819

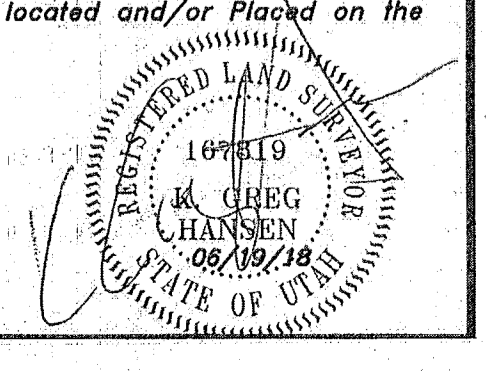

Drawn By: <i>lsh</i> Date: 06/19/18 Designed By: Checked By: Approved By: Scale: 1" = 40' Drawing File: 18-113\15.RDS JOB NUMBER: 18-113			HANSEN & ASSOCIATES, INC. Consulting Engineers and Land Surveyors 538 North Main Street, Brigham, Utah 84302 Visit us at www.hansen.net Brigham City, Ogden (435) 725-3491 (601) 399-4666 (435) 725-8272 Celebrating 60 Years of Business
Property Survey for Mary Petrie 4414 South 5225 West Hooper City, Weber County, Utah A Part of the Southeast Quarter of Section 7, Township 5 North, Range 2 West, Salt Lake Base & Meridian	No. _____ Date _____ By _____ Revision _____		
Sheet 1 of 1 Sheets			