

Found Ogden City  
Centerline Monument  
Taylor Ave. & 24th Street

Found Ogden City  
Centerline Monument  
Custer Ave. & 24th Street

Found Ogden City  
Centerline Monument  
Taylor Ave. & Capitol Street

Found Ogden City  
Centerline Monument  
Custer Ave. & Capitol Street

**Narrative**  
The purpose of this survey was to establish and set the property corners of the parcel as shown and described hereon. The survey was ordered by Leleao Tabish. The control used to establish the property corners was the Robinson's Subdivision Plat recorded in the In Book 5, Page 22 in the Weber County Recorder's Office along with the existing Ogden City Centerline Monuments as shown hereon. The basis of bearing is the Centerline of Taylor Avenue from the found Monument at the intersection of Taylor Avenue and Capitol Street to the found Monument at the intersection of Taylor Avenue and 24th Street which bears North 00°18'09" East, Utah North, State Plane, Calculated N.A.D.83 Bearing.

**AS SURVEYED BOUNDARY DESCRIPTION**

ALL OF LOT 9, AND THE NORTH 8.76 FEET OF LOT 8, BLOCK 1, ROBINSON'S SUBDIVISION, OGDEN CITY, WEBER COUNTY, UTAH. MORE PARTICULARLY DESCRIBED AS FOLLOWS:

A PART OF THE SOUTHWEST QUARTER OF SECTION 27, TOWNSHIP 6 NORTH, RANGE 1 WEST OF THE SALT LAKE BASE AND MERIDIAN.

BEGINNING AT THE NORTHWEST CORNER OF SAID LOT 8 BEING A POINT ON THE EAST RIGHT-OF-WAY LINE OF TAYLOR AVENUE LOCATED 169.00 FEET NORTH 01°18'09" EAST ALONG THE MONUMENTED CENTERLINE OF SAID TAYLOR AVENUE AND 49.50 FEET SOUTH 88°41'51" EAST FROM THE CENTERLINE MONUMENT AT THE INTERSECTION OF TAYLOR AVENUE AND CAPITOL STREET;

RUNNING THENCE SOUTH 88°42'04" EAST 160.85 FEET TO THE NORTHEAST CORNER OF SAID LOT 8; THENCE SOUTH 01°18'09" WEST 63.67 FEET TO A POINT 8.76 FEET SOUTH OF THE SOUTHEAST CORNER OF SAID LOT 8; THENCE NORTH 88°41'51" WEST 160.85 FEET PARALLEL TO THE SOUTH LINE OF SAID LOT 8 TO SAID EAST RIGHT-OF-WAY LINE; THENCE NORTH 01°18'09" EAST 63.66 FEET ALONG SAID EAST RIGHT-OF-WAY LINE TO THE POINT OF BEGINNING. CONTAINING 0.235 ACRES.

**LEGEND**

- Subject Property Line
- Adjoining Property Line
- Robinson's Subdivision Lot Line
- Centerline
- - - Ditch
- Concrete Wall
- - - Fence Line (Wire)
- - - Fence Line (wood or Vinyl)
- Found rebar set by others
- Found rebar set by others
- Section Corner
- Calculated Section Corner

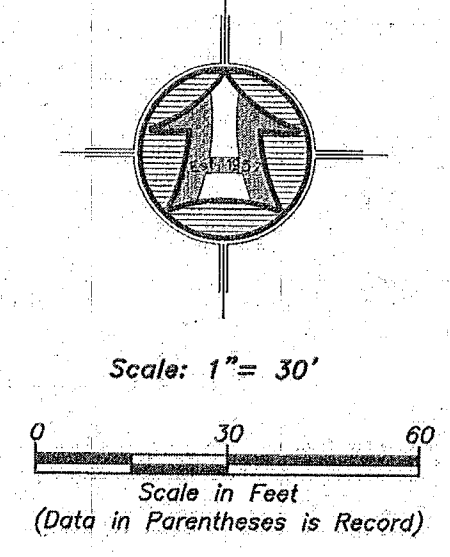

RECEIVED  
SEP 26 2018  
BY: GLO

**SURVEYOR'S CERTIFICATE**

I, K. Greg Hansen, do hereby certify that I am a Registered Professional Land Surveyor in the State of Utah in accordance with Title 38, Chapter 22, Professional Engineers and Professional Land Surveyors Act; and by the authority of the owners, I have completed a survey of the property described and shown hereon this plat in accordance with Section 17-23-17 and have verified all measurements, and that the same has been surveyed and monuments have been located and/or placed on the ground as represented on the plat hereon.

Signed this 26th day of July, 2018.

K. Greg Hansen PLS  
Utah Land Surveyor Licence No. 167819

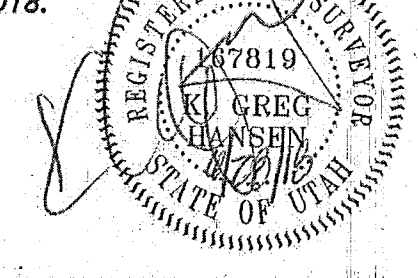

 <b>HANSEN &amp; ASSOCIATES, INC.</b> Consulting Engineers and Land Surveyors 558 North Main Street, Brigham, Utah 84302 Visit us at <a href="http://www.hansen.net">www.hansen.net</a> Brigham, UT 84302 (801) 388-4405 (435) 728-8272 Celebrating 60 Years of Business				No.	Date	By	Revision
Drawn By: JS Date: 06/26/2018 Designed By: Checked By: Approved By: Scale: 1" = 30' Drawing File: 18-3-14315.dwg JOB NUMBER: 18-3-143							
Property Survey for <b>Leleao Tabish</b> 2424 Taylor Ave. Ogden, Weber County, Utah A Part of the Southwest Quarter of Section 27 Township 6 North, Range 1 West, S.L.B.&M.							
RECEIVED SEP 26 2018 BY: GLO							
<b>SURVEYOR'S CERTIFICATE</b> I, K. Greg Hansen, do hereby certify that I am a Registered Professional Land Surveyor in the State of Utah in accordance with Title 38, Chapter 22, Professional Engineers and Professional Land Surveyors Act; and by the authority of the owners, I have completed a survey of the property described and shown hereon this plat in accordance with Section 17-23-17 and have verified all measurements, and that the same has been surveyed and monuments have been located and/or placed on the ground as represented on the plat hereon. Signed this 26th day of <u>July</u> , 2018. K. Greg Hansen PLS Utah Land Surveyor Licence No. 167819 							
Sheet <b>1</b> of <b>1</b> Sheets							