

AS SURVEYED BOUNDARY DESCRIPTION
 ALL OF LOT 15, TAYLOR ESTATES PLAT II, NORTH OGDEN, WEBER COUNTY, UTAH SURVEY.
 A PART OF THE NORTHWEST QUARTER OF SECTION 29, TOWNSHIP 7 NORTH, RANGE 1 WEST OF THE SALT LAKE BASE AND MERIDIAN.
 SUBJECT TO AN EASEMENT RECORDED AS ENTRY NO. 878719 IN THE WEBER COUNTY RECORDERS OFFICE FOR INGRESS AND EGRESS ACROSS A PORTION OF AN EXISTING DRIVEWAY WHICH RUNS ALONG THE SOUTHERLY LINE OF SAID LOT 15.

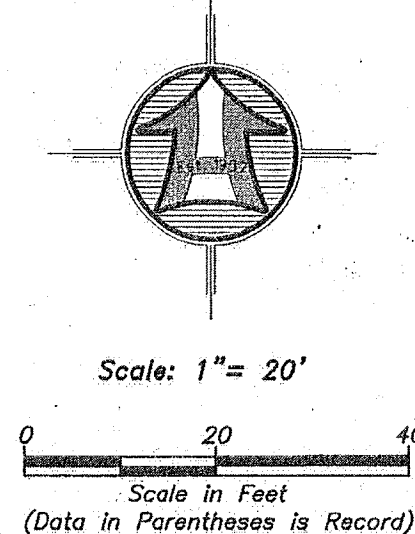

- LEGEND**
- Subject Property Line
 - - - Adjoining Property Line
 - Previous Property Line
 - Centerline
 - Ditch
 - Field Separation Line
 - Fence Line (Wire)
 - Fence Line (wood or Vinyl)
 - Street Monument
 - Found rebar set by others
 - Set 3/8"x24" Rebar With Cap
 - Section Corner
 - Calculated Section Corner

Narrative
 The purpose of this survey was to establish and set the property corners of the parcel as shown and described hereon. The survey was ordered by Carolyn White. The control used to establish the property corners was the existing fence lines within Taylor Estates Plat II. The basis of bearing is the East line of Lot 15 of said Taylor Estates Plat II which bears South 16°10'00" West, an Assumed bearing as shown on said Taylor Estates Plat II.

C1
 $\Delta = 61^{\circ}57'48''$
 $R = 50.00'$
 $L = 54.07'$
 $LC = 51.48'$
 $N 25^{\circ}53'10'' W$

RECEIVED
 SEP 26 2018
 BY: 6102

SURVEYOR'S CERTIFICATE

I, K. Greg Hansen, do hereby certify that I am a Registered Professional Land Surveyor in the State of Utah in accordance with Title 58, Chapter 22, Professional Engineers and Professional Land Surveyors Act; and by the authority of the owners, I have completed a survey of the property described and shown hereon this plat in accordance with Section 17-23-17 and have verified all measurements, and that the same has been surveyed and monuments have been located and/or Placed on the ground as represented on the plat hereon.
 Signed this 27th day of JUNE, 2018.

K. Greg Hansen PLS
 Utah Land Surveyor Licence No. 167819

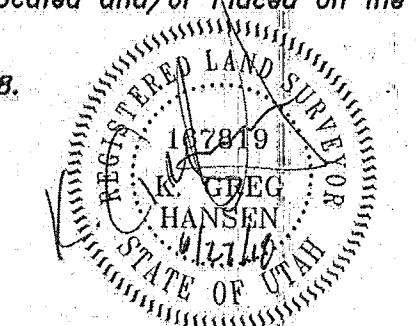

HANSEN & ASSOCIATES, INC. Consulting Engineers and Land Surveyors 538 North Main Street, Brigham, Utah 84302 Visit us at www.ha-inc.net Brigham City, Ogden (435) 723-3481 (801) 389-4605 (435) 759-8272 Celebrating 60 Years of Business	
Drawn By: RS Designed By: Checked By: Approved By: Scale: 1" = 20' Drawing File: 18-3-151v16.dwg JOB NUMBER: 18-3-151	Date: 06/25/2018 No. _____ Date _____ By _____
Property Survey for Carolyn White 3072 North 175 West North Ogden, Weber County, Utah A Part of the Northwest Quarter of Section 29 Township 7 North, Range 1 West, S.L.B.&M.	
Sheet 1 of 1 Sheets	