

**Narrative**

The purpose of this survey was to establish and set the property corners of the parcel as shown and described hereon. The survey was ordered by Lynn Bennett. All of the deed descriptions for the properties between 700 South and Ronald Holmes Property Tax ID No. 15-037-0018 fit well together but do not fit existing fence lines. There is a discrepancy of approximately 22' due to a long section. The deeds were shifted to fit the existing fence lines. When shifted to the existing fence lines the Verna Harp Property Tax ID No. 15-040-0001 ends up with an excess of approximately 6.5'. The properties to the south were given their deed distances which fit all existing fence and now curbs in the area. The control used to establish the property corners was the existing fence lines and Morris Meadows Subdivision recorded as Entry No. 2855305 in the Weber County Records Office along with the existing Weber County Survey Monumentation surrounding Section 13, T6N, R2W, SLB&M. The basis of bearing is the West line of said Section which bears North 0°30'49" East, Utah North, State Plane, Calculated N.A.D.83 Bearing.

**AS SURVEYED BOUNDARY DESCRIPTION**

A PART OF THE SOUTHWEST QUARTER OF SECTION 13, TOWNSHIP 6 NORTH, RANGE 2 WEST OF THE SALT LAKE BASE AND MERIDIAN.

BEGINNING AT A POINT ON THE EAST RIGHT-OF-WAY LINE OF SR-126 (1900 WEST STREET) BEING THE NORTHEAST CORNER OF GERALD BISCHOFF PROPERTY RECORDED AS ENTRY NO. 1250626 IN THE WEBER COUNTY RECORDERS OFFICE LOCATED 2253.42 FEET NORTH 0°30'48" EAST ALONG THE WEST LINE OF SAID SECTION AND 74.77 FEET SOUTH 88°45'25" EAST FROM THE SOUTHWEST CORNER OF SAID SECTION 13, SAID POINT DESCRIBED OF RECORD AS BEING LOCATED NORTH 0°44'00" EAST 1322.10 FEET AND SOUTH 89°16'00" EAST 380.00 FEET AND NORTH 01°04'00" EAST 910.00 FEET AND NORTH 89°16'00" WEST 335.29 FEET FROM THE SOUTHWEST CORNER OF SAID SOUTHWEST QUARTER;

RUNNING THENCE NORTH 01°08'35" EAST (NORTH 0°44'00" EAST BY RECORD) 135.00 FEET ALONG SAID EAST RIGHT-OF-WAY LINE TO THE SOUTHWEST CORNER OF RONALD HOLMES PROPERTY ENTRY NO. 1485582; THENCE SOUTH 87°03'13" EAST 336.46 FEET (SOUTH 87°33'41" EAST 336.16 FEET BY RECORD) ALONG THE SOUTH LINE OF SAID RONALD HOLMES PROPERTY TO THE WEST LINE OF MORRIS MEADOWS SUBDIVISION ENTRY NO. 2855305; THENCE SOUTH 01°28'35" WEST (SOUTH 01°04'00" WEST BY RECORD) 125.00 FEET ALONG THE WEST LINE OF SAID MORRIS MEADOWS SUBDIVISION TO THE NORTHEAST CORNER OF SAID GERALD BISCHOFF PROPERTY; THENCE NORTH 88°45'25" WEST 335.57 FEET (NORTH 89°16'00" WEST 335.29 FEET BY RECORD) ALONG THE NORTH LINE OF SAID GERALD BISCHOFF PROPERTY TO THE POINT OF BEGINNING. CONTAINING 1.003 ACRES.

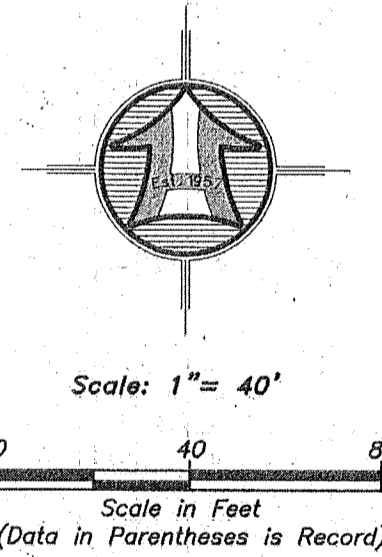

**LEGEND**

- Subject Property Line
- - - - - Adjoining Property Line
- - - - - Previous Property Line
- Centerline
- Flowline
- Top Bank
- - - - - Fence Line (Wire)
- - - - - Easement
- Street Monument
- Found rebar and curbs set by HAI
- Set 5/8"x24" Rebar With Cap
- Section Corner
- Calculated Section Corner

**SURVEYOR'S CERTIFICATE**

I, K. Greg Hansen, do hereby certify that I am a Registered Professional Land Surveyor in the State of Utah in accordance with Title 58, Chapter 22, Professional Engineers and Professional Land Surveyors Act; and by the authority of the owners, I have completed a survey of the property described and shown hereon this plat in accordance with Section 17-23-17 and have verified all measurements; and that the same has been surveyed and monuments have been located and/or placed on the ground as represented on the plat hereon.

Signed this 1<sup>st</sup> day of April, 2018.

K. Greg Hansen PLS  
Utah Land Surveyor Licence No. 167819

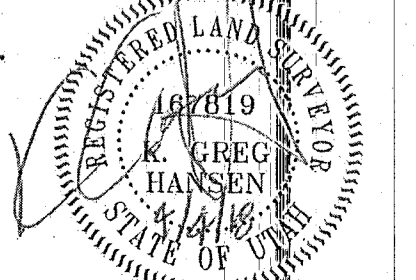

<b>HANSEN &amp; ASSOCIATES, INC.</b> Consulting Engineers and Land Surveyors 528 North Main Street, Brigham, Utah 84302 Visit us at <a href="http://www.hansen.net">www.hansen.net</a> Brigham City, Ogden, Logan (435) 723-4491 (801) 889-1805 (435) 752-8272 Celebrating 60 Years of Business	
Drawn By: RS Designed By: Checked By: Approved By: Scale: 1" = 40' Drawing File: 18-3-38015.dwg JOB NUMBER: 18-3-38	Date: 3/29/2018 No. _____ Date _____ By _____ Revision _____
<b>Lynn Bennett</b> Property Survey for 528 South 1900 West Marriot-Statersville, Weber County, Utah A Part of the Southwest Quarter of Section 13 Township 6 North, Range 2 West, S.L.B.&M.	
RECEIVED SEP 16 2018 BY: G.103	
Sheet <b>1</b> of <b>1</b> Sheets	