

**PARCEL 140950006 BOUNDARY DESCRIPTION**

THE SOUTH HALF OF LOT 3, BLOCK 2, MAULE ADDITION, OGDEN CITY SURVEY, WEBER COUNTY, UTAH, MORE PARTICULARLY DESCRIBED AS FOLLOWS:

BEGINNING AT A POINT BEING LOCATED NORTH 1°17'59" EAST 316.76 FEET ALONG THE CENTERLINE OF MALAN AVENUE AND NORTH 90°00'00" EAST 127.40 FEET FROM THE CENTERLINE MONUMENT AT MALAN AVENUE AND 29TH STREET; RUNNING THENCE NORTH 0°44'33" EAST 72.00 FEET; THENCE SOUTH 88°41'11" EAST 141.71 FEET TO THE WEST RIGHT-OF-WAY LINE OF WHEELLOCK AVENUE; THENCE SOUTH 1°18'49" WEST 72.00 FEET ALONG SAID RIGHT-OF-WAY LINE; THENCE NORTH 88°41'11" WEST 140.99 FEET TO THE POINT OF BEGINNING. CONTAINS 10,177 SQUARE FEET MORE OR LESS.

**PARCEL 140930006 BOUNDARY DESCRIPTION**

A PART OF THE NORTHWEST QUARTER OF SECTION 34, TOWNSHIP 6 NORTH, RANGE 1 WEST OF THE SALT LAKE BASE AND MERIDIAN, MORE PARTICULARLY DESCRIBED AS FOLLOWS:

BEGINNING AT A POINT ON THE EAST RIGHT-OF-WAY LINE OF MALAN AVENUE BEING LOCATED NORTH 1°17'59" EAST 353.93 FEET ALONG THE CENTERLINE OF MALAN AVENUE AND NORTH 90°00'00" EAST 25.01 FEET FROM THE CENTERLINE MONUMENT AT MALAN AVENUE AND 29TH STREET; RUNNING THENCE NORTH 1°17'59" EAST 60.00 FEET ALONG SAID RIGHT-OF-WAY LINE, THENCE SOUTH 88°43'01" EAST 101.52 FEET; THENCE SOUTH 0°43'43" WEST 60.00 FEET; THENCE NORTH 88°42'01" WEST 102.12 FEET TO THE POINT OF BEGINNING. CONTAINS 6,109 SQUARE FEET MORE OR LESS.

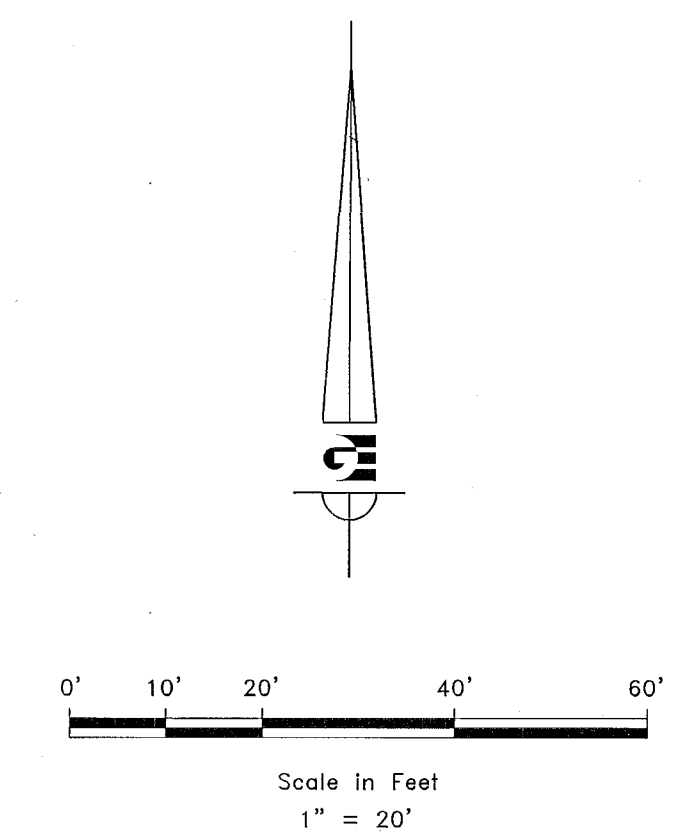

- LEGEND**
- ◆ OGDEN CITY CENTERLINE MONUMENT AS NOTED
  - SET 24" REBAR AND CAP MARKED GARDNER ENGINEERING
  - PROPERTY BOUNDARY
  - - - STREET CENTERLINE
  - - - ADJACENT PARCEL

**NARRATIVE**

THE PURPOSE OF THIS SURVEY WAS TO ESTABLISH THE BOUNDARY OF THE PROPERTY AS SHOWN AND DESCRIBED HEREON. THE SURVEY WAS ORDERED BY SANDY MILLER. THE CONTROL USED TO ESTABLISH THE BOUNDARY WAS THE EXISTING OGDEN CITY SURVEY MONUMENTATION AS SHOWN HEREON. THE BASIS OF BEARING IS THE MONUMENTED CENTERLINE OF MALAN AVENUE BETWEEN THE OGDEN CITY CENTERLINE MONUMENT OF MAULE DRIVE AND MALAN AVENUE AND THE OGDEN CITY CENTERLINE MONUMENT OF 29TH STREET AND MALAN AVENUE WHICH BEARS NORTH 1°17'59" EAST. CURRENT VESTING DEED OCCUPATION WERE USED TO ESTABLISH THE BOUNDARY.

**SURVEYOR'S CERTIFICATE**

I, KLINT H. WHITNEY, DO HEREBY CERTIFY THAT I AM A LICENSED PROFESSIONAL LAND SURVEYOR IN THE STATE OF UTAH AND THAT I HOLD CERTIFICATE NO. 8227228 IN ACCORDANCE WITH TITLE 58, CHAPTER 22, OF THE PROFESSIONAL ENGINEERS AND LAND SURVEYORS ACT; I FURTHER CERTIFY THAT BY AUTHORITY OF THE OWNERS I HAVE COMPLETED A SURVEY OF THE PROPERTY DESCRIBED ON THIS RECORD OF SURVEY PLAT IN ACCORDANCE WITH SECTION 17-23-20 AND HAVE VERIFIED ALL MEASUREMENTS; THAT THE REFERENCE MONUMENTS SHOWN ON THIS RECORD OF SURVEY PLAT ARE LOCATED AS INDICATED AND ARE SUFFICIENT TO RETRACE OR REESTABLISH THIS SURVEY; AND THAT THE INFORMATION SHOWN HEREIN IS SUFFICIENT TO ACCURATELY ESTABLISH THE LATERAL BOUNDARIES OF THE HEREIN DESCRIBED TRACT OF REAL PROPERTY.

SIGNED THIS 24<sup>TH</sup> DAY OF OCTOBER, 2018.

RECEIVED  
OCT 24 2018  
BY: 6119

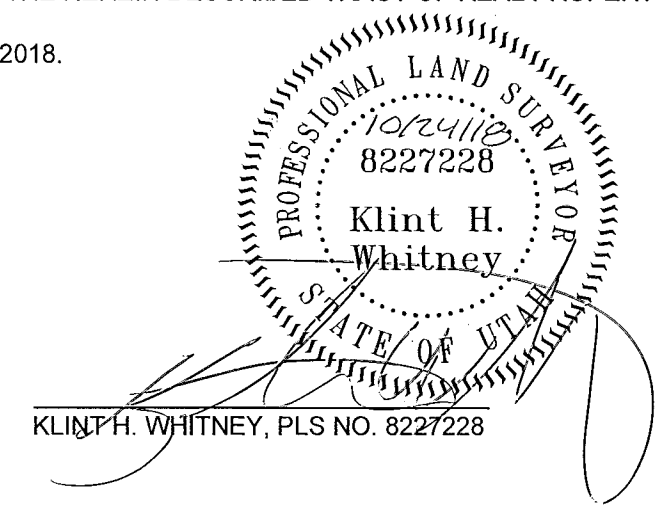

SCALE: 1:20_XREF	DATE: 10/3/2018
DESIGN: MJL	DRAWN: MJL
CHECKED: KHW	DWG.: 140950006 - MAULE SURVEY 10/3/2018 - SANDY MILLER SURVEYORS ANDY MILLER, DWS

REVISIONS	DESCRIPTION
DATE	

PROPERTY SURVEY FOR SANDY MILLER  
2847 WHEELLOCK AVE & 2846 MALAN AVE  
PART OF LOT 3, BLOCK 2, MAULE ADDITION, OGDEN CITY SURVEY  
LOCATED IN THE NW 1/4 OF SEC. 34, T6N, R1W, S.L.B. & M.

**GARDNER ENGINEERING**  
CIVIL - LAND PLANNING  
MUNICIPAL - LAND SURVEYING

5150 SOUTH 375 EAST OGDEN, UT  
OFFICE: 801.476.0202 FAX: 801.476.0866

S1  
1