

Northwest Corner of Sec. 13,  
T. 6 N., R. 2 W., SLB&M  
Found Weber Co. Brass Cap  
Monument

North Quarter Corner of Sec. 13,  
T. 6 N., R. 2 W., SLB&M  
Calculated Position from Found  
Witness Corner Monument

Northeast Corner of Sec. 13,  
T. 6 N., R. 2 W., SLB&M  
Found Weber Co. Brass Cap  
Monument

**HLF & C Investment Company**  
15-035-0016  
Cont. 12.195 Acres

**AS SURVEYED BOUNDARY DESCRIPTION**

A PART OF THE NORTHEAST QUARTER AND A PART OF THE NORTHWEST QUARTER OF SECTION 13, TOWNSHIP 6 NORTH, RANGE 2 WEST OF THE SALT LAKE BASE AND MERIDIAN.

BEGINNING AT A POINT ON THE SOUTH RIGHT-OF-WAY LINE OF 200 SOUTH STREET LOCATED 80.10 FEET NORTH 89°08'13" WEST ALONG THE NORTH LINE OF SAID NORTHWEST QUARTER TO AN EXISTING WITNESS CORNER AND 1194.31 FEET SOUTH 01°13'56" WEST FROM THE NORTH QUARTER CORNER OF SAID SECTION 13 (BASIS OF BEARING IS THE NORTH LINE OF SAID NORTHEAST QUARTER WHICH BEARS NORTH 89°12'21" WEST);

RUNNING THENCE SOUTH 88°46'30" EAST 332.02 FEET ALONG SAID SOUTH RIGHT-OF-WAY LINE; THENCE SOUTH 00°15'00" WEST (SOUTH BY RECORD) 1827.34 FEET TO THE CENTER OF MILL CREEK; THENCE ALONG THE CENTER OF SAID MILL CREEK THE FOLLOWING EIGHT (8) COURSES: (1) SOUTH 73°55'23" WEST 32.13 FEET; (2) NORTH 86°08'17" WEST 73.75 FEET; (3) NORTH 45°33'41" WEST 37.60 FEET; (4) NORTH 11°19'12" WEST 78.52 FEET; (5) NORTH 00°10'33" EAST 193.68 FEET; (6) NORTH 34°45'25" WEST 141.35 FEET; (7) NORTH 49°43'14" WEST 71.70 FEET; AND (8) NORTH 36°39'03" WEST 80.91 FEET; THENCE NORTH 00°15'00" EAST (NORTH BY RECORD) 1313.97 FEET TO THE POINT OF BEGINNING. CONTAINING 12.195 ACRES.

**Narrative**  
The purpose of this survey was to establish and set the property corners of the parcel as shown and described herein. The survey was ordered by Joe Adair. The control used to establish the property corners was the existing Weber County Survey Monumentation surrounding Section 13, T6N, R2W, SLB&M. The basis of bearing is the North line of said Section which bears North 0°47'39" East, Utah North, State Plane, Calculated N.A.D.83 Bearing.

**SURVEYOR'S CERTIFICATE**

I, K. Greg Hansen, do hereby certify that I am a Registered Professional Land Surveyor in the State of Utah in accordance with Title 58, Chapter 22, Professional Engineers and Professional Land Surveyors Act; and by the authority of the owners, I have completed a survey of the property described and shown hereon this plat in accordance with Section 17-23-17 and have verified all measurements, and that the same has been surveyed and monuments have been located and/or placed on the ground as represented on the plat hereon.

Signed this 27th day of March, 2019.

K. Greg Hansen PLS  
Utah Land Surveyor Licence No. 167819



RECEIVED  
BY: 6233

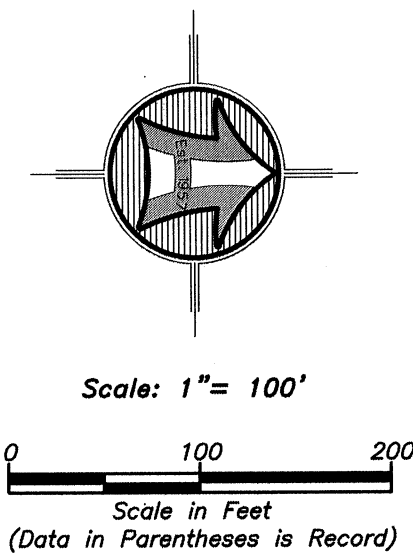

- LEGEND**
- Subject Property Line
  - Adjoining Property Line
  - Easement
  - Centerline
  - Ditch
  - Top Bank
  - Fence Line
  - Found rebar set by others
  - Set 5/8"x24" Rebar With Cap
  - Section Corner

Property Survey for  
**Joe Adair**  
±1500 West 200 North  
Marriott-Statenville, Weber County, Utah  
A Part of the Northeast Quarter of Section 13  
Township 6 North, Range 2 West, S.L.B.&M.

Drawn By: RS Date: 03/11/2019  
Checked By: Approved By: Scale: 1" = 100'  
Drawing File: 19-3-28\15.dwg  
JOB NUMBER: 19-3-28

**HANSEN & ASSOCIATES, INC.**  
Consulting Engineers and Land Surveyors  
538 North Main Street, Brigham, Utah 84302  
Visit us at www.hales.net  
Brigham City, Ogden, Layton, Provo, St. George, UT  
(435) 728-9446 (fax) (435) 728-9972  
Celebrating 60 Years of Business

Sheet  
**1**  
of  
**1**  
Sheets