

EAST QUARTER CORNER SECTION 29, T7N, R1W, S.L.B.&M. (FOUND 3" WEBER COUNTY BRASS CAP MONUMENT IN RING AND LID COVER)

AS- SURVEYED BOUNDARY DESCRIPTION

A PART OF THE SOUTHEAST QUARTER OF SECTION 29, TOWNSHIP 7 NORTH, RANGE 1 WEST, OF THE SALT LAKE BASE AND MERIDIAN. BEGINNING AT A POINT ON THE SOUTHERLY RIGHT-OF-WAY LINE OF ELBERTA DRIVE BEING LOCATED SOUTH 00°31'02" WEST 304.04 FEET ALONG THE EAST LINE OF SAID SOUTHEAST QUARTER AND NORTH 90°00'00" WEST 919.44 FEET FROM THE NORTHEAST CORNER OF SAID SOUTHEAST QUARTER; RUNNING THENCE SOUTH 09°22'02" WEST 542.00 FEET; THENCE NORTH 82°31'24" WEST 196.34 FEET; THENCE NORTH 08°49'23" EAST 308.88 FEET; THENCE SOUTH 84°35'58" EAST 78.56 FEET; THENCE NORTH 17°05'07" EAST 288.72 FEET TO SAID SOUTHERLY RIGHT-OF-WAY LINE; THENCE ALONG SAID SOUTHERLY RIGHT-OF-WAY LINE SOUTH 60°05'13" EAST 90.84 FEET TO THE POINT OF BEGINNING. CONTAINING 2.00 ACRES.

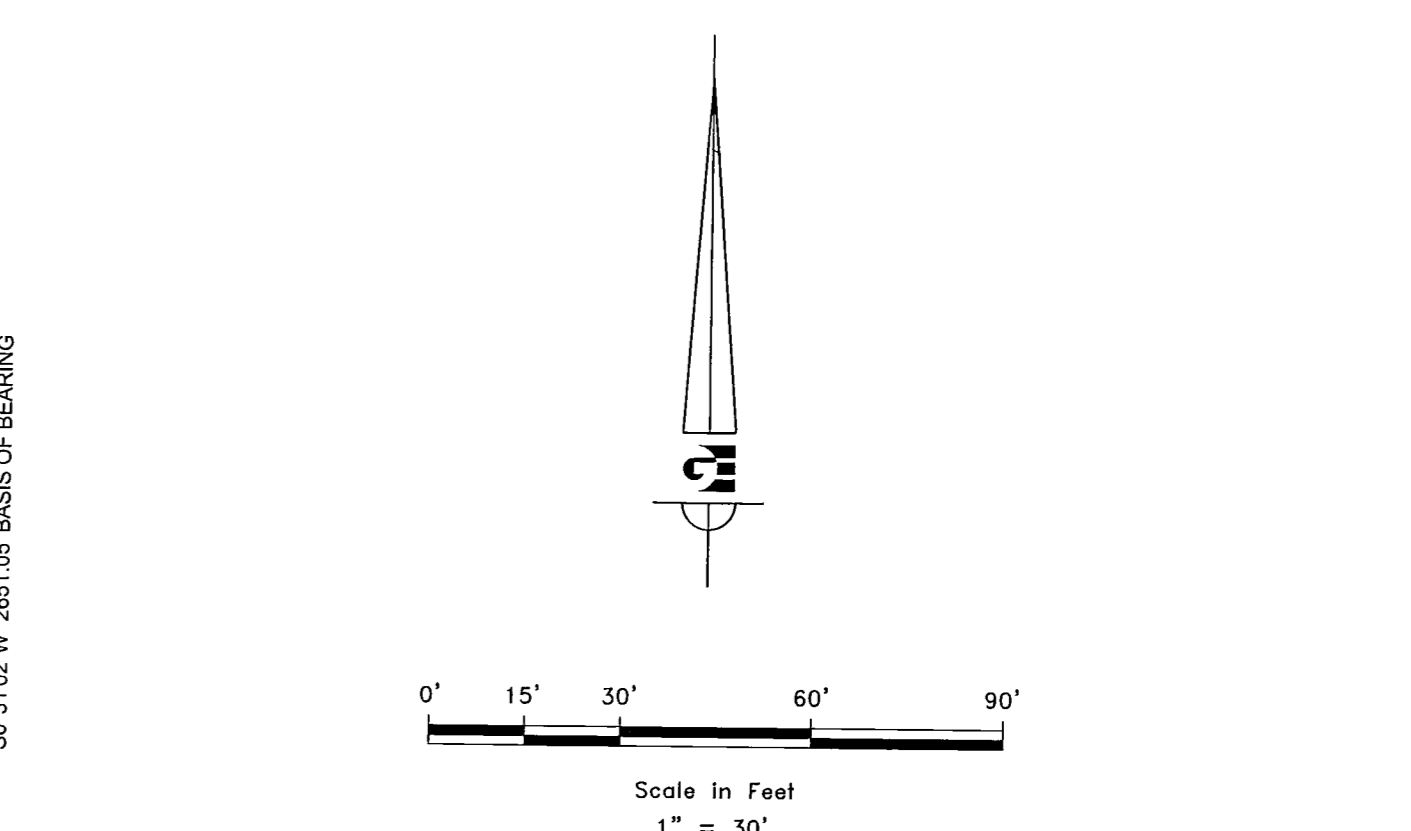

- LEGEND
- ◆ WEBER COUNTY MONUMENT AS NOTED
 - SET 24" REBAR AND CAP MARKED GARDNER ENGINEERING
 - SUBDIVISION BOUNDARY
 - LOT LINE
 - - - ADJACENT PARCEL
 - - - SECTION LINE
 - - - EASEMENT
 - X — EXISTING FENCE LINE

SOUTHEAST CORNER OF SEC. 29, T7N, R1W, S.L.B.&M. (FOUND WEBER COUNTY BRASS CAP MONUMENT)

NARRATIVE

THE PURPOSE OF THE SURVEY WAS TO ESTABLISH AND SET THE PROPERTY CORNERS OF THE PARCEL AS SHOWN AND DESCRIBED HEREON. THE SURVEY WAS ORDERED BY CHRISSEY KOTTER. THE CONTROL USED TO ESTABLISH THE PROPERTY CORNERS WAS THE EXISTING WEBER COUNTY SURVEY MONUMENTS SURROUNDING SECTION 29, TOWNSHIP 7 NORTH, RANGE 1 WEST, OF THE SALT LAKE BASE AND MERIDIAN. THE BASIS OF BEARING IS THE EAST LINE OF THE SOUTHEAST QUARTER OF SAID SECTION 29 WHICH BEARS SOUTH 00°31'02" WEST WEBER COUNTY, UTAH NORTH, NAD83 STATE PLANE GRID BEARING. THE NORTH LINE OF ELBERTA DRIVE WAS ESTABLISHED BY THE 1982 ROAD RE-ALIGNMENT PLAT AS NOTED HEREON. THE RECORD DESCRIPTION WAS ROTATED TO MATCH OCCUPATION OF THE ADJACENT PROPERTIES EXTENDING EAST TO WASHINGTON BLVD. THE SOUTH PROPERTY LINE WAS ADJUSTED TO MATCH A FOUND GREAT BASIN REBAR. THE WEST 288.72 FOOT LEG WAS ADJUSTED TO MATCH A FOUND CURB NAIL.

SURVEYOR'S CERTIFICATE

I, KLINT H. WHITNEY, DO HEREBY CERTIFY THAT I AM A LICENSED PROFESSIONAL LAND SURVEYOR IN THE STATE OF UTAH AND THAT I HOLD CERTIFICATE NO. 8227228 IN ACCORDANCE WITH TITLE 58, CHAPTER 22, OF THE PROFESSIONAL ENGINEERS AND LAND SURVEYORS ACT. I FURTHER CERTIFY THAT BY AUTHORITY OF THE OWNERS I HAVE COMPLETED A SURVEY OF THE PROPERTY DESCRIBED ON THIS RECORDED SURVEY PLAT IN ACCORDANCE WITH SECTION 17-23-20 AND HAVE VERIFIED ALL MEASUREMENTS; THAT THE REFERENCE MONUMENTS SHOWN ON THIS RECORDED SURVEY PLAT ARE LOCATED AS INDICATED AND ARE SUFFICIENT TO RETRACE OR REESTABLISH THIS SURVEY; AND THAT THE INFORMATION SHOWN HEREIN IS SUFFICIENT TO ACCURATELY ESTABLISH THE LATERAL BOUNDARIES OF THE HEREIN DESCRIBED TRACT OF REAL PROPERTY.

SIGNED THIS 18 DAY OF APRIL, 2019.

RECEIVED
MAY 06 2019
BY: 6248

KLINT H. WHITNEY, PLS NO. 8227228

SCALE: 1:30 XREF

DATE:	3/6/19
DESIGN:	
DRAWN:	KHW
CHECKED:	KHW

DWG.: 180501 - MEC SURVEYING - CHRISSEY KOTTER SURVEYING - CHRISSEY KOTTER SURVEYING

REVISIONS	DESCRIPTION
DATE	

PROPERTY SURVEY FOR DAVE AND CHRISSEY KOTTER
359 ELBERTA DRIVE, NORTH OGDEN, UTAH
LOCATED IN THE SOUTHEAST QUARTER OF SECTION 29,
TOWNSHIP 7 NORTH, RANGE 1 WEST, S.L.B. AND M.

GARDNER ENGINEERING
CIVIL - LAND PLANNING
MUNICIPAL - LAND SURVEYING
5150 SOUTH 375 EAST OGDEN, UT
OFFICE: 801.476.0202 FAX: 801.476.0066

S1
1