

BOUNDARY DESCRIPTION
 ALL OF LOT 32, AMENDED PLAT OF GREENWOOD VILLAGE, SOUTH OGDEN, WEBER COUNTY, UTAH
 ACCORDING TO THE OFFICIAL PLAT THEREOF.

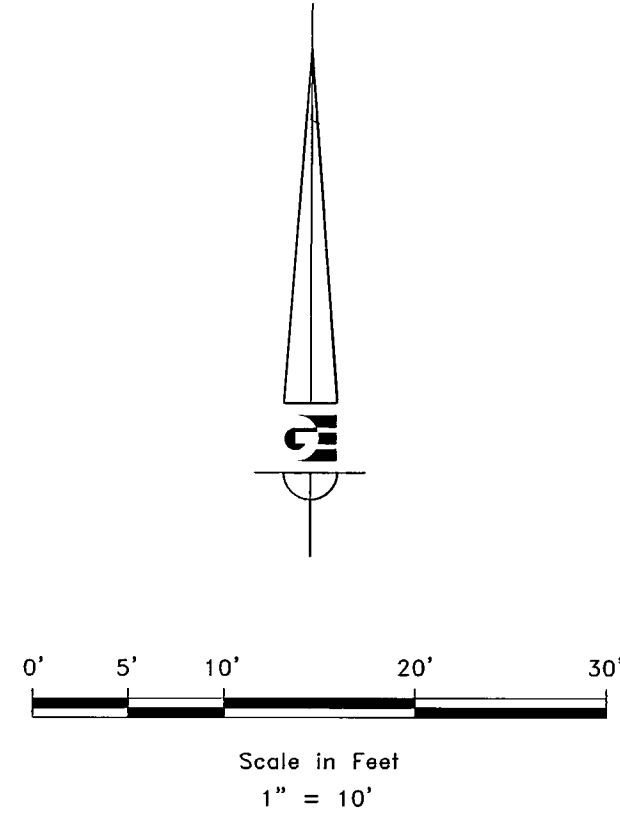

- LEGEND**
- WEBER COUNTY MONUMENT AS NOTED
 - SET 24" REBAR AND CAP MARKED GARDNER ENGINEERING
 - SUBDIVISION BOUNDARY
 - LOT LINE
 - ADJACENT PARCEL
 - SECTION LINE
 - EASEMENT
 - EXISTING FENCE LINE

NARRATIVE

THE PURPOSE OF THE SURVEY WAS TO SET THE PROPERTY CORNERS OF THE PARCEL AS SHOWN AND DESCRIBED HEREON. THE SURVEY WAS ORDERED BY JAKE HARDY. OWNERSHIP WAS DETERMINED BY WARRANTY DEED RECORDED AS ENTRY NUMBER 2967773 OF THE WEBER COUNTY RECORDS. BOUNDARY LOCATION WAS DETERMINED BY THE DEDICATED PLAT OF THE AMENDED PLAT OF GREENWOOD VILLAGE AND RECORD OF SURVEY NUMBER 1738. THE BASIS OF BEARING IS THE NORTH LINE OF THE NORTHEAST QUARTER OF SECTION 8, TOWNSHIP 5 NORTH, RANGE 1 WEST, SALT LAKE BASE AND MERIDIAN WHICH BEARS SOUTH 89°26'02" EAST, WEBER COUNTY, UTAH NORTH, NAD 83 STATE PLANE GRID BEARING.

SURVEYOR'S CERTIFICATE

I, KLINT H. WHITNEY, DO HEREBY CERTIFY THAT I AM A LICENSED PROFESSIONAL LAND SURVEYOR IN THE STATE OF UTAH AND THAT I HOLD CERTIFICATE NO. 8227228 IN ACCORDANCE WITH TITLE 58, CHAPTER 22, OF THE PROFESSIONAL ENGINEERS AND LAND SURVEYORS ACT. I FURTHER CERTIFY THAT BY AUTHORITY OF THE OWNERS I HAVE COMPLETED A SURVEY OF THE PROPERTY DESCRIBED ON THIS RECORD OF SURVEY PLAT IN ACCORDANCE WITH SECTION 17-23-20 AND HAVE VERIFIED ALL MEASUREMENTS, THAT THE REFERENCE MONUMENTS SHOWN ON THIS RECORD OF SURVEY PLAT ARE LOCATED AS INDICATED AND ARE SUFFICIENT TO RETRACE OR REESTABLISH THIS SURVEY, AND THAT THE INFORMATION SHOWN HEREIN IS SUFFICIENT TO ACCURATELY ESTABLISH THE LATERAL BOUNDARIES OF THE HEREIN DESCRIBED TRACT OF REAL PROPERTY.

SIGNED THIS 18TH DAY OF APRIL, 2019.

RECEIVED
 MAY 06 2019
 BY: 6250

PROFESSIONAL LAND SURVEYOR
 4/18/19
 8227228
 Klint H. Whitney
 STATE OF UTAH

KLINT H. WHITNEY, PLS NO. 8227228

SCALE:	1:10 XREF
DATE:	4/18/19
DESIGN:	
DRAWN:	KRW
CHECKED:	KRW

REVISIONS	DESCRIPTION

PROPERTY SURVEY FOR JAKE HARDY
 4021 SOUTH HILLCREST CIRCLE, SOUTH OGDEN, UT
 LOCATED IN THE NORTHEAST QUARTER OF SECTION 8,
 TOWNSHIP 7 NORTH, RANGE 1 WEST, S.L.B. AND M.

GARDNER ENGINEERING
 CIVIL, LAND PLANNING
 MUNICIPAL - LAND SURVEYING
 5150 SOUTH 375 EAST, OGDEN, UT
 OFFICE: 801-476-0202 FAX: 801-476-0056

S1
 1