

RECEIVED
AUG 21 2019
BY: 6321

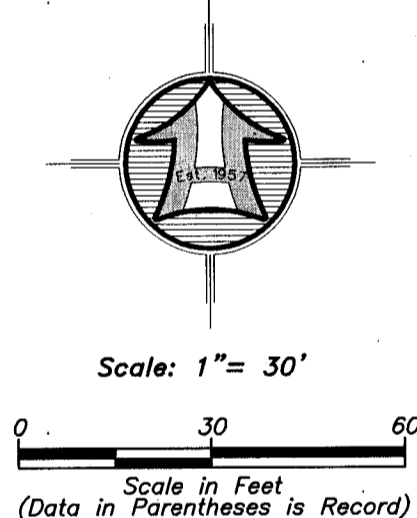

- LEGEND**
- Subject Property Line
 - - - Adjoining Property Line
 - - - Nelson Park Addition
 - - - Centerline
 - - - Fence Line
 - - - Existing Concrete
 - Ogden City Survey Monument
 - Found rebar set by others
 - Set 5/8"x24" Rebar With Cap

Narrative

The purpose of this survey was to establish and set the property corners of the parcel as shown and described hereon. The survey was ordered by Mike Tonkinson for Rollan Tonkinson. The control used to establish the property corners was the official plat of Nelson Park Addition recorded in Book 3 of Plats, Page 17 in the Weber County Recorder's Office and the 36th Street Vacation recorded as Entry No. 2563839 along with the existing Ogden City Survey Monumentation surrounding Block 22, Nelson Park Addition. Only 3 monuments were found around Block 22, Nelson Park Addition. The distance from the monuments in 35th Street from Fowler Avenue to Jackson Avenue is longer than the platted distance. Therefore the distance of Block 22 was proportioned in an East/West direction to fit the found monuments. No monument was found at Fowler Avenue and 36th Street. The found monument at Jackson Avenue and 36th Street is not near the platted distance shown on Nelson Park Addition. Therefore the monument at Jackson Avenue and 35th Street was held along with the platted dimensions in a North/South direction. On this survey Fowler Avenue is parallel to Jackson Avenue and 36th Street is parallel to 35th Street as shown on the official plat Nelson Park Addition. The basis of bearing is the centerline of Jackson Avenue from the monument at 36th Street to the monument at 35th Street which bears North 1°17'27" East, Utah North, State Plane, calculated N.A.D.83 bearing.

AS SURVEYED BOUNDARY DESCRIPTION

A PART OF LOTS 25 TO 28, BLOCK 22, NELSON PARK ADDITION, OGDEN CITY, WEBER COUNTY, UTAH SURVEY. MORE PARTICULARLY DESCRIBED AS FOLLOWS:

BEGINNING AT A POINT BEING 15.00 FEET SOUTH OF THE NORTH LINE OF LOT 28 (POINT DESCRIBED OF RECORD AS 15.00 FEET SOUTH AND 53.00 FEET WEST OF THE NORTHEAST CORNER OF LOT 28) LOCATED 167.29 FEET NORTH 01°17'27" EAST ALONG THE CENTERLINE OF JACKSON AVENUE AND 86.08 FEET NORTH 88°40'58" WEST FROM THE OGDEN CITY MONUMENT AT JACKSON AVENUE AND 36TH STREET;

RUNNING THENCE SOUTH 01°17'27" WEST 112.97 FEET (SOUTH 114.00 FEET MORE OR LESS BY RECORD TO THE NORTH RIGHT-OF-WAY LINE OF 36TH STREET; THENCE NORTH 89°06'45" WEST 52.07 FEET (WEST 52.00 FEET BY RECORD) ALONG SAID NORTH RIGHT-OF-WAY LINE; THENCE NORTH 01°17'27" EAST 113.36 FEET (NORTH 114.00 FEET MORE OR LESS BY RECORD) TO A POINT 15.00 FEET SOUTH OF THE NORTH LINE OF SAID LOT 28; THENCE SOUTH 88°40'58" EAST 52.07 FEET (EAST 52.00 FEET BY RECORD) PARALLEL TO THE NORTH LINE OF SAID LOT 28 TO THE POINT OF BEGINNING. CONTAINING 0.135 ACRES.

SURVEYOR'S CERTIFICATE

I, K. Greg Hansen, do hereby certify that I am a Registered Professional Land Surveyor in the State of Utah in accordance with Title 58, Chapter 22, Professional Engineers and Professional Land Surveyors Act; and by the authority of the owners, I have completed a survey of the property described and shown hereon this plat in accordance with Section 17-23-17 and have verified all measurements, and that the same has been surveyed and monuments have been located and/or placed on the ground as represented on the plat hereon.

Signed this 9th day of July, 2019.

K. Greg Hansen PLS
Utah Land Surveyor License No. 167819

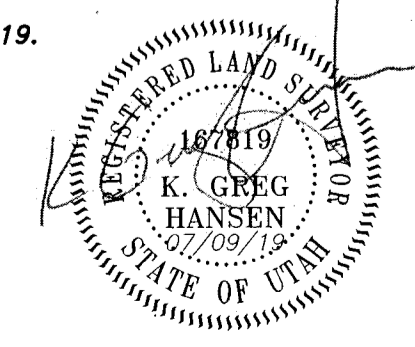

<p>Drawn By: RS Date: 06/27/2019</p> <p>Designed By: _____</p> <p>Checked By: _____</p> <p>Approved By: _____</p> <p>Scale: 1" = 30'</p> <p>Drawing File: 19-3-144\15.dwg</p> <p>JOB NUMBER: 19-3-144</p>		<p>HANSEN & ASSOCIATES, INC. Consulting Engineers and Land Surveyors 538 North Main Street, Brigham, Utah 84302 Visit us at www.hansen.net Brigham City, UT at 801.398-4905 (435) 755-8272 Celebrating over 60 Years of Business</p>	
<p>Property Survey for Rollan Tonkinson 980 East 36th Street Ogden, Weber Co., Utah</p> <p>A Part of the Northeast Quarter of Section 4, T 5 N., R 1 W., S.L.B.&M.</p>			
<p>Sheet 1 Of 1 Sheets</p>	<p>No. _____</p> <p>Date _____</p> <p>By _____</p>		