

**Narrative**

The purpose of this survey was to establish and set the property corners of the parcel as shown and described hereon. The survey was ordered by Armando Lujan. The control used to establish the property corners was the existing curbpins, rebar, CL monuments and existing fence lines in Camarren Cove Estates Subdivision-Phase 5 recorded as Entry No. 738976 in the Weber County Recorder's Office along with the existing Weber County Survey Monumentation surrounding Section 27, T7N, R1W, SLB&M. All but one of the curbpins were found during this survey. It appeared that the curbpins were the original curbpins set when the subdivision was recorded in 1978. We also found a RR Spike at the intersection of 3075 North and 1350 East and small rebar at the NE & SE corners of Lot 166 and the SE corner of Lot 165. However, all of the monuments found do not fit the recorded plat as shown hereon. The curbpins in front of Lot 161 were held as best evidence of where Lot 161 was originally laid out. By using these curbpins, most of the other curbpins within the subdivision fall in harmony. The basis of bearing is the west line of said Section which bears South 0°33'44" West, an Assumed Bearing, Rotated to match the bearings as shown on the Official Plat of Camarren Cove Estates Subdivision-Phase 5.

**LOT 161 BOUNDARY DESCRIPTION**

ALL OF LOT 161, CAMARREN COVE ESTATES SUBDIVISION-PHASE 5, NORTH OGDEN, WEBER COUNTY, UTAH.

RECEIVED  
AUG 21 2019  
BY: 6223

Northwest Corner of Sec. 27,  
T. 7 N., R. 1 W., SLB&M  
Found Weber Co. 3" Brass Cap  
Monument

Southwest Corner of Sec. 27,  
T. 7 N., R. 1 W., SLB&M  
Found Weber Co. 3" Brass Cap  
Monument

- LEGEND**
- Subject Property Line
  - - - Subdivision Boundary
  - Adjoining Property Line
  - Centerline
  - - - Property Line Projection
  - - - Fence Line
  - Street Monument
  - Found rebar set by others
  - Set 5/8"x24" Rebar With Cap
  - Section Corner

**SURVEYOR'S CERTIFICATE**

I, K. Greg Hansen, do hereby certify that I am a Registered Professional Land Surveyor in the State of Utah in accordance with Title 58, Chapter 22, Professional Engineers and Professional Land Surveyors Act; and by the authority of the owners, I have completed a survey of the property described and shown hereon this plat in accordance with Section 17-23-17 and have verified all measurements, and that the same has been surveyed and monuments have been located and/or placed on the ground as represented on the plat hereon.

Signed this 6th day of August, 2019.

K. Greg Hansen PLS  
Utah Land Surveyor Licence No. 167819

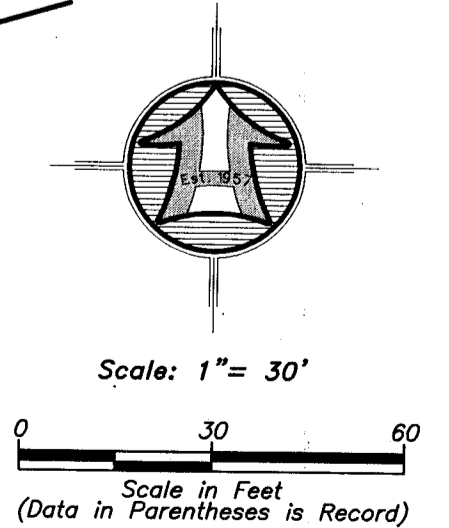

Drawn By: RS	Date: 08/06/2019
Designed By:	
Checked By:	
Approved By:	
Scale: 1" = 30'	
Drawing File: 19-3-16215.dwg	
JOB NUMBER: 19-3-162	

Property Survey for  
**Armando Lujan**  
1370 East 3090 North  
North Ogden, Weber Co., Utah  
A Part of the Northwest Quarter of  
Section 27, T 7 N., R 1 W., S.L.B.&M.

Sheet  
**1**  
Of  
**1**  
Sheets

HANSEN & ASSOCIATES, INC.  
Consulting Engineers and Land Surveyors  
538 North Main Street, Brigham, Utah 84302  
Visit us at www.hais.net  
Brigham City Ogden Logan  
(435) 723-3461 (801) 399-4905 (435) 752-8272  
Celebrating over 60 Years of Business